

**FINAL REPORT**

**AECOM** Imagine it.  
Delivered.

Renewable Energy Resource Assessment Study Report

South Gloucestershire Council

November 2021

**FINAL REPORT**

## Quality information

Prepared by	Checked by	Verified by	Approved by
Parham Andisheh	Simon Hartley	Simon Hartley	Simon Hartley
Sustainability Consultant	Regional Director	Regional Director	Regional Director

## Revision History

Revision	Revision date	Details	Authorized	Name	Position
V1.0	01-09-2021	Draft Issue to SGC	SH	S Hartley	Regional Director
V2.0	11-10-2021	Draft Issue to SGC	SH	S Hartley	Regional Director
V3.0	26-10-2021	Draft Issue to SGC	SH	S Hartley	Regional Director
V4.0	18-11-2021	Draft Issue to SGC	SH	S Hartley	Regional Director

## Distribution List

# Hard Copies	PDF Required	Association / Company Name

Prepared for:

South Gloucestershire Council

Prepared by:

Simon Hartley  
Regional Director  
T: +44-(0)29-2005 1500  
E: [simon.hartley@aecom.com](mailto:simon.hartley@aecom.com)

AECOM Limited  
1 Callaghan Square  
Cardiff CF10 5BT  
United Kingdom

T: +44-(0)29-2005 1500

[aecom.com](http://aecom.com)

© 2020 AECOM Limited. All Rights Reserved.

This document has been prepared by AECOM Limited ("AECOM") for sole use of our client (the "Client") in accordance with generally accepted consultancy principles, the budget for fees and the terms of reference agreed between AECOM and the Client. Any information provided by third parties and referred to herein has not been checked or verified by AECOM, unless otherwise expressly stated in the document. No third party may rely upon this document without the prior and express written agreement of AECOM.

## Table of Contents

Acronyms and Abbreviations .....	16
Report – Summary .....	19
Introduction .....	19
Why is this Renewable Energy Resource Assessment Study Important? .....	19
Climate Change .....	19
How Is the Earth’s Temperature Rising? .....	19
What Are We Doing to Prevent This? .....	19
South Gloucestershire’s Input into Reducing Carbon Emissions .....	20
Technologies .....	21
Defining the Units Used in this RERAS .....	21
Electricity vs Heat Output .....	21
Technologies Addressed in this Study .....	22
On-Shore Wind Turbines .....	22
Solar Photovoltaic .....	22
Hydropower Energy Generators .....	23
Solar Thermal .....	23
Heat Pumps .....	23
Combined Heat and Power .....	23
Energy Storage – Hydrogen .....	24
Methodology .....	24
Potential Installed Capacity .....	24
Future Energy Consumption .....	26
Baseline Energy Consumption vs Future Consumption .....	27
Results - Theoretical Maximum Available Resource .....	29
Scenarios for a Carbon Neutral South Gloucestershire in 2030 .....	34
Heat Opportunity and Strategic Site Assessment .....	36
Planning Policy Approaches .....	37
Renewable Energy Resource Assessment Study (RERAS) Main Report .....	40
1. Introduction .....	40
1.1 South Gloucestershire .....	40
1.2 Purpose of this Assessment .....	41
1.3 Method Employed in this Renewable Energy Resource Assessment .....	42
1.4 Why this Renewable Energy Resource Assessment Study is Important .....	42
1.4.1 Wider Corporate Role .....	43
1.5 Scope of this Renewable Energy Assessment .....	43
1.5.1 Planning .....	43
1.6 Technology .....	43
1.6.1 Energy Hierarchy .....	43
1.6.2 Transport .....	44
1.6.3 Stand-Alone Electricity Generating Assets .....	44
1.6.4 Soundness .....	44
1.7 Defining Renewable Energy and Low and Zero Carbon Energy .....	44
1.7.1 Renewable Energy .....	44
1.8 Renewable Technologies Addressed in this Renewable Energy Resource Assessment Study .....	46
1.8.1 On-Shore Wind Turbines .....	47
1.8.2 Solar Photovoltaic .....	47
1.8.3 Hydropower Energy Generators .....	48
1.8.4 Solar Thermal .....	48
1.8.5 Heat Pumps .....	49

1.8.6	Combined Heat and Power .....	49
1.8.6.1	Biomass Combined Heat & Power and/or Biomass Boilers .....	50
1.8.6.2	Health Concerns .....	51
1.8.6.3	Future Direction of Biomass.....	51
1.8.6.4	Incineration (Energy from Waste) .....	51
1.8.6.5	Anaerobic Digestion .....	51
1.8.6.6	Landfill Gas .....	52
1.8.7	Marine Renewable Technologies.....	52
1.8.8	Low Carbon Energy Options .....	53
1.8.8.1	Waste Heat.....	53
1.8.8.2	The Non-Biodegradable Fraction of the Output from Energy from Waste Plants.....	54
1.8.9	Hydrogen .....	54
1.8.10	Nuclear Fusion.....	55
1.8.11	Power vs Energy Output.....	56
1.8.12	Electricity vs Heat Output .....	56
2.	Policy Context and Drivers for Renewable Energy.....	57
3.	Baseline Energy Consumption and Low and Zero Carbon Energy Technologies in South Gloucestershire.....	60
3.1	Introduction .....	60
3.2	Baseline Energy Consumption in South Gloucestershire in the Baseline Year .....	60
3.3	Existing Capacity of Low and Zero Carbon Energy Technology Installations and Energy Generation in South Gloucestershire .....	64
4.	Wind Energy Resource .....	68
4.1	Introduction .....	68
4.2	Mapping .....	68
4.2.1	Primary Constraints .....	71
4.2.2	Identification of Wind Search Areas.....	73
4.2.3	Other Constraints for Further Consideration .....	76
4.3	Proximity to Grid and Grid Capacity .....	77
4.4	Landscape Sensitivity Assessment .....	77
4.5	Further Constraints to Wind Energy Sites .....	77
4.6	Summary and Potential Opportunities for Future Development.....	77
5.	Solar PV Farms.....	79
5.1	Introduction .....	79
5.2	Mapping .....	79
5.2.1	Primary Constraints .....	81
5.2.2	Identification of Solar PV Search Areas .....	82
5.2.3	Other Constraints to Consider Further .....	84
5.3	Proximity to Grid and Grid Capacity .....	85
5.4	Landscape Sensitivity Assessment .....	85
5.5	Further Constraints to Solar PV Farms .....	85
5.6	Summary and Potential Opportunities for Future Development.....	86
6.	Proximity to Grid and Grid Capacity for Wind and Solar PV SAs .....	87
7.	Wind and Solar PV Search Areas and Landscape Sensitivity Assessment .....	89
8.	Biomass Energy Resource .....	93
8.1	Introduction .....	93
8.2	Energy Crops.....	93
8.2.1	Mapping .....	93
8.2.1.1	Primary Constraints.....	96
8.2.1.2	Identification of Biomass Resource.....	96
	Installed Power and Heat Generation Capacity.....	97
8.3	Wood Fuel .....	98

8.4	Further Constraints to Biomass Energy Resource .....	99
8.5	Summary and Potential Opportunities for Future Development.....	99
9.	Energy from Waste .....	101
9.1	Introduction .....	101
9.2	Waste Summary .....	102
10.	Hydropower.....	104
10.1	Introduction .....	104
10.2	Hydropower Potential .....	104
10.3	Summary .....	105
11.	Role of Storage in the Network.....	106
11.1	Introduction .....	106
11.2	Local Insights.....	107
11.2.1	Distribution Future Energy Scenarios projections .....	107
11.2.2	Planning activity.....	108
11.2.3	District Network Operator Constraint Management Zones .....	108
11.3	Summary .....	109
12.	Hydrogen .....	111
12.1	Introduction .....	111
12.2	Hydrogen Projects in the West of England .....	112
12.3	Local Opportunities .....	113
12.4	2030 Hydrogen Demand in South Gloucestershire .....	113
12.5	Mapping .....	114
12.6	Potential Opportunities for Future Development .....	116
13.	Heat Opportunity and Strategic Site Assessment.....	117
13.1	Introduction .....	117
13.2	Heat Opportunities Mapping Process.....	118
13.2.1	Identifying Anchor “Heat” Loads and “Clusters” .....	118
13.2.1.1	Social Housing Associations in South Gloucestershire .....	119
13.2.2	Mapping Residential Heat Demand and Density.....	119
13.2.3	Map Locations of Strategic New Development Sites .....	120
13.2.4	Identifying Existing Energy Infrastructure and District Heating Networks .....	120
13.2.5	Identifying Potential Renewable or Low Carbon Heat Sources .....	121
13.3	Mapping of Heat Demand and Viability Assessment.....	121
13.3.1	Evaluation of District Heating Network Opportunities.....	121
13.3.1.1	Oldbury Nuclear Power Station Site .....	123
13.3.2	Heat Demand.....	124
13.3.3	Route and Physical Barriers Consideration.....	124
13.3.4	Land Ownership.....	124
13.3.5	Renewable or Low Carbon Energy Sources .....	125
13.4	Summary and Conclusions.....	126
13.5	Next Steps .....	126
14.	Projected Energy Consumption in South Gloucestershire in 2030 .....	127
14.1	Understanding the Future Energy Scenarios and the Distribution Future Energy Scenarios .....	127
14.1.1	Future Energy Scenarios .....	127
14.1.2	Distribution Future Energy Scenarios.....	128
14.1.3	Guidance on Input to the Distribution Future Energy Scenarios .....	130
14.2	Predicting 2030 Future Energy Consumption .....	131
14.3	Building Integrated Renewables Projection.....	132
14.3.1	Calculation Method .....	132
14.3.1.1	Baseline .....	132
14.3.1.2	Projection .....	132

14.3.2	Building Integrated Renewable Energy Uptake in 2030	132
14.3.2.1	Domestic Thermal Technologies	132
14.3.2.2	Non-Domestic Thermal Technologies	133
14.3.2.3	Buildings Mounted Renewable Electricity Generators	133
14.4	Energy Consumption Projections	133
14.4.1	Calculation Method	133
14.4.1.1	Baseline	133
14.4.1.2	Projection	133
14.4.1.3	Industrial Process and Manufacturing Energy Consumption	134
14.4.1.4	2030 Decarbonisation Aim Adjustment	134
14.5	2030 Energy Consumption in South Gloucestershire	135
15.	Identifying the Contributions of South Gloucestershire	138
15.1	Introduction	138
15.1.1	Calculating Energy from Installed Capacity	138
15.2	Maximum Theoretical Potential of New Renewable Energy Solutions	139
15.3	South Gloucestershire Maximum Potential Renewable Energy Generation and 2030 Energy Consumption	140
15.4	Scenarios for a Carbon Neutral South Gloucestershire in 2030	142
	Scenario 1 - Meeting the Distribution Future Energy Scenario Projection by 2030	145
	Scenario 2 – Meet 33% of South Gloucestershire’s Consumption by 2030	146
	Scenario 3 – Meeting South Gloucestershire’s 2030 Electricity Consumption	147
16.	Advice on Community Engagement	148
16.1	Community Engagement	148
16.2	Community Energy Projects	149
17.	Planning Policy Approach	151
17.1	What is this section about?	151
17.2	Scope of the Policy Recommendations	152
17.2.1	Nationally Significant Infrastructure Projects (NSIP)	152
17.2.2	Broader Net Zero Agenda	152
17.2.3	Exclusions	153
17.3	Recommended Policy Approaches	153
17.4	General policy recommendations	168
17.5	Further work	168
Appendix A : Policy Context and Drivers for Renewable Energy		169
A.1	Introduction	169
A.2	International policy context	169
	The Kyoto Protocol (1998)	169
	The Paris Agreement (2016)	169
A.3	National Policy	169
	Climate Change Act (2008)	169
	National Planning Policy Framework	169
	UK National Energy and Climate Plan (NECP)	171
	UK Industrial Strategy (2017)	171
	Resources and Waste Strategy, 2018	171
	Waste Management Plan for England, 2021	171
	National Planning Policy for Waste, 2014	172
	Clean Growth Strategy (CGS) (2017)	172
	25 Year Environment Plan (2018)	172
	The UK Heat Strategy (2013)	173
	Building Regulations in England (Part L and Part F)	173
A.4	Financial Incentive Schemes	174
	Renewable Heat Incentive (RHI)	174

Energy Company Obligation (ECO).....	174
Smart Export Guarantee (SEG).....	174
Heat Networks Delivery Unit (HNDU).....	174
Green Heat Network Fund (GHNF) Scheme.....	175
A.5 Ten Point Plan for a Green Industrial Revolution.....	175
Offshore Wind Sector Deal (March 2020).....	175
A.6 Emerging National Policy.....	176
Environment Bill 2020.....	176
White Paper: Energy.....	176
White Paper: Planning for the Future.....	178
A.7 West of England Planning Policy Context.....	178
The West of England Joint Waste Core Strategy (2011).....	178
West of England Local Industrial Strategy (2019).....	182
A.8 South Gloucestershire Local Plan Policy.....	182
Core Strategy (2013).....	182
Key Issue 1 & Objectives.....	182
High-Quality Design and Responding to Climate Change.....	183
Policy CS1: High-Quality Design.....	183
Policy CS1 Criterion 8: Sustainable Construction.....	183
Policy CS1 Criteria 10: Waste Reduction.....	183
Policy CS2: Green Infrastructure.....	183
Policy CS3: Renewable and Low Carbon Energy Generation.....	183
Policy CS4: Renewable and Low Carbon District Heat Networks.....	184
Policy CS4A: Presumption in Favour of Sustainable Development.....	184
Policy CS37: Nuclear Related Development.....	184
Policy CS15: Distribution of Housing.....	185
Policies, Sites and Places (PSP) Plan (2017).....	185
Policy PSP6: Onsite Renewable and Low Carbon Energy.....	185
Policy PSP26: Enterprise Areas.....	185
Policy PSP28: Rural Economy.....	186
Policy PSP46: Oldbury New Nuclear Build.....	186
South Gloucestershire Resource and Waste Strategy: 2020 and Beyond.....	186
Renewables: Supplementary Planning Document (SPD).....	187
Hydropower.....	187
Landfill Gas.....	187
Solar PV– Ground-Mounted.....	187
Solar PV– Roof-Mounted.....	188
Biomass.....	188
Wind 188	
South Gloucestershire Climate Emergency Strategy.....	188
Appendix B : Clean Growth Strategy – Power Sector Policies and Proposals.....	189
Appendix C : Existing Low and Zero Carbon Energy Technologies.....	192
Appendix D : Existing Renewable Electricity Generated in South Gloucestershire.....	195
Appendix E : Wind Energy Resource.....	196
E.1 Introduction.....	196
E.2 Mapping.....	196
Step 1: South Gloucestershire Boundary.....	199
Step 2: Consideration of the Primary Constraints to Wind Energy Development.....	199
Step 3: Remaining Land Parcels After Applying the Constraints.....	202
Step 4: Wind Resource Based on Wind Speed in South Gloucestershire.....	204
Step 5: Remaining Potential Wind Resource After Combining W3 Maps (Resource After Constraining) and W4 (Showing Sufficient Wind Speeds).....	205



Step 6: Identification of Wind Search Areas and Maximum Available Wind Resource .....	206
Maximum Available Wind Resource .....	207
Step 7: Combined Wind Search Areas in South Gloucestershire .....	209
Step 8: Wind Resource Other Constraints to Consider Further .....	211
Step 9: Remaining Area of Local Search Areas after Applying Selected Additional Constraints .....	212
Wind SAs and MOD and Aviation Safeguarded Areas .....	216
Wind SAs and Conservation Areas (Heritage) .....	217
Buffer Zones for Local Search Areas .....	217
E.3 Pipeline Projects and Repowering Consideration .....	218
E.4 Proximity to Grid and Grid Capacity .....	219
E.5 Landscape Sensitivity Assessment .....	221
E.6 Further Constraints to Wind Energy Sites .....	225
E.7 Potential Opportunities for Future Development .....	225
Appendix F : Wind Energy Primary Resource Constraints Table .....	226
Appendix G : Wind Energy Resource Other Constraints Table .....	228
Appendix H : Solar PV Farm .....	229
H.1 Introduction .....	229
H.2 Mapping .....	229
Step1: South Gloucestershire Boundary .....	231
Step 2: Consideration of the Primary Constraints to Ground Mounted Solar PV Development .....	231
Step 3: Remaining Land Parcels After Applying the Constraints .....	233
Step 4: Ground Mounted Solar PV Resource Based on Land Orientation and Inclination .....	234
Step 5: Remaining Available Land for Ground Mounted Solar PV After Combining S3 Map (Resource After Constraining) and S4 Map (Land Orientation and Inclination) .....	236
Step 6: Identification of Final Potential Solar PV Resource and Maximum Available Resource .....	237
Step 7: Defining Solar PV Search Areas .....	238
Step 8: Solar PV Resource Other Constraints – to Consider Further .....	239
Remaining Area of SAs after Applying Selected Additional Constraints .....	240
H.3 Pipeline Projects .....	245
H.4 Proximity to Grid and Grid Capacity .....	247
H.5 Landscape Sensitivity Assessment .....	249
H.6 Further Constraints to Solar PV Farm Sites .....	252
H.7 Potential Opportunities for Future Development .....	252
Appendix I : Solar PV Farms Primary Constraints Table .....	253
Appendix J : Solar PV Farms Other Constraints Table .....	254
Appendix K : Biomass Energy Resource .....	255
K.1 Introduction .....	255
K.2 Energy Crops .....	255
Mapping .....	255
Step 1: Land Area for Energy Crops Cultivation .....	256
Step 2: Primary Constraints to Biomass Energy Crops Resource .....	257
Step 3: Remaining Land After Applying the Constraints and Crop Yield .....	258
Installed Power and Heat Generation Capacity .....	259
K.3 Wood Fuel .....	260
Usable Land and Yield .....	260
Installed Power and Heat Generation Capacity .....	260
Further Constraints to Biomass Energy Resource .....	261
17.6 Potential Opportunities for Future Development .....	261
Appendix L : Biomass Energy Resource Primary Constraints Table .....	263
Appendix M : Energy from Waste .....	264

M.1	Introduction .....	264
M.2	Municipal Solid Waste .....	265
M.3	Commercial and Industrial Waste.....	266
M.4	Food Waste.....	268
M.5	Agricultural Waste.....	269
	Animal Manure .....	269
	Poultry Litter.....	270
M.6	Sewage Sludge.....	271
M.7	Waste Summary .....	272
Appendix N : Future Energy Scenarios.....		274
Appendix O : Renewable Energy Generation Load Factors.....		277
Appendix P : Future Energy Demand Building Integrated Renewables Projections Data Source .....		278
Appendix Q : Potential Hydropower Sites.....		279
Appendix R : Accelerating DFES 2050 Projection to 2030 .....		281
Appendix S : Installation of Maximum Potential.....		282

## Figures

Figure 1: Image of Sea Ice.....	19
Figure 2: The Greenhouse Effect.....	19
Figure 3: Wind Farm .....	22
Figure 4: Ground Mounted Solar PV Array .....	22
Figure 5: Hydropower Energy Generator.....	23
Figure 6: Diagram of a Solar Thermal Collector .....	23
Figure 7: Diagram of a Ground Source Heat Pump System.....	23
Figure 8: Diagram of a Combined Heat and Power System.....	23
Figure 9: Diagram of a H <sub>2</sub> Molecule.....	24
Figure 10: W7-SG: Combined Wind Search Areas in South Gloucestershire Map .....	25
Figure 11: S7-SG: Solar PV Search Areas in South Gloucestershire Map.....	25
Figure 12: Breakdown of Current and Projected 2030 Energy Consumption in South Gloucestershire .....	27
Figure 13: Existing Installed Capacity of Renewable Electricity Generators in South Gloucestershire in 2020 .....	28
Figure 14: Existing Installed Capacity of Renewable Heat Generators in South Gloucestershire in 2020 .....	28
Figure 15: Maximum Theoretical Potential Electricity Generation in South Gloucestershire in 2030 ..	33
Figure 16: Maximum Theoretical Potential Heat Generation in South Gloucestershire in 2030, Excluding Electric Heating .....	33
Figure 17: Theoretical Maximum Electricity and Heat Generation and Consumption within South Gloucestershire in 2030 .....	34
Figure 18: E4-SG: Heat Opportunities for South Gloucestershire Map .....	36
Figure 19: Earthcott Wind Farm - Alveston .....	47
Figure 20: A Rooftop Solar Array .....	47
Figure 21: A Run-of-River Hydropower Scheme .....	48
Figure 22: Systematic of a Solar Thermal System.....	49
Figure 23: Example of an Anaerobic Digestion (AD) System from Feedstock to Final Use .....	52
Figure 24: Nuclear Fusion Diagram <sup>66</sup> .....	55
Figure 25: E1-SG: Indicative Heat Demand Based on Gas Consumption – Total Gas Consumption by MSOA in 2019 (MWh per Year) Map.....	62
Figure 26: E2-SG: Total Electricity Consumption by MSOA in 2019 (MWh per Year) Map .....	62
Figure 27: Breakdown of Existing Energy Consumption (GWh) in South Gloucestershire .....	63
Figure 28: Chart Showing Comparison of Energy Consumption Data for the Councils Considered....	63
Figure 29: R1-SG: Sites of Existing Renewable Energy in South Gloucestershire .....	65
Figure 30: Existing Installed Capacity of Renewable Electricity Generators in South Gloucestershire	67
Figure 31: Existing Installed Capacity of Renewable Heat Generators in South Gloucestershire .....	67
Figure 32: Difference Between the Existing Renewable Energy Generation (GWh) and Current (2020) Energy Consumption. Current Electricity Consumption Includes Electric Heating consumption .....	67

Figure 33: Flowchart of Wind Energy Resource Mapping Process .....	70
Figure 34: W2-SG-1.0MW: Wind Resource for 1.0MW Wind Turbines Constraints – Areas to Exclude from Further Consideration Map .....	72
Figure 35: W7-SG: Combined Wind Search Areas in South Gloucestershire Map .....	74
Figure 36: W8-SG-1.0MW: Wind Resource Other Constraints – to Consider Further Map .....	76
Figure 37: Flow Chart of Solar PV Mapping Process .....	80
Figure 38: S2-SG: Solar PV Resource Constraints - Areas to Exclude from Further Consideration Map .....	82
Figure 39: S7-SG: Solar PV Search Areas in South Gloucestershire Map .....	83
Figure 40: S8-SG: Solar PV Resource Other Constraints – to Consider Further Map.....	85
Figure 41: SAs Proximity to Grid and Grid Capacity Ranking Key (Refer to W16 and S16 Maps in the Accompanying Document ‘South Gloucestershire RERAS – Maps’) .....	87
Figure 42: W16-SG-1.0MW: 1.0MW Wind Search Areas and Grid Connection in South Gloucestershire Map .....	88
Figure 43: S16-SG: 50MW Solar PV Search Areas and Grid Connection in South Gloucestershire Map .....	88
Figure 44 Steps Taken in Landscape sensitivity Study for Wind Farm Search Areas .....	89
Figure 45 Steps Taken in Landscape Sensitivity Study for Solar PV Farm Search Areas .....	89
Figure 46: W17-SG-1MW: Wind Local Search Areas for 1 MW Wind Turbines from W6 map and Landscape Sensitivity Results in Band D (101 to 120) in South Gloucestershire Map .....	92
Figure 47: S17-SG-Band A: Solar Local Search Areas from S6 Map and Landscape Sensitivity Results in Band A ( $\leq 5$ ha) in South Gloucestershire Map .....	92
Figure 48: Flowchart of Energy Crop Mapping Process .....	95
Figure 49: B2-SG: Biomass Resource Primary Constraints – Areas to Exclude from Further Consideration Map .....	96
Figure 50: B3-SG: Remaining Biomass Resource (Grade 4 Agricultural Land) After Constraining of Ancient and Broadleaved Woodlands, Primary Heritage and Ecological Constraints and Existing and Consented Renewable Generation Installations Map.....	97
Figure 51: Distribution Future Energy Scenarios Battery Storage Projections.....	108
Figure 52: W16-SG-1.0MW: 1.0MW Wind Search Areas and Grid Connection in South Gloucestershire Map .....	110
Figure 53: S16-SG: 50MW Solar PV Search Areas and Grid Connection in South Gloucestershire Map .....	110
Figure 54: The Hydrogen Value Chain. Source: Regen, 2021. ....	112
Figure 55: Manufacturing Industrial Clusters in the West of England With Employment Related to Chemical Process and High-Grade Heat Demand. ....	113
Figure 56: Electricity Demand for Hydrogen Production in the UK.....	114
Figure 57: FES 2050 Hydrogen Supply for the UK.....	114
Figure 58: H1-SG: Wind Local Search Areas and Industrial Clusters for Potential Green Hydrogen Generation and Demand Map.....	115
Figure 59: H2-SG: Solar PV Local Search Areas and Industrial Clusters for Potential Green Hydrogen Generation and Demand Map.....	116
Figure 60: E3-SG: Indicative Residential Heat Demand Total Gas Consumption (MWh per Year) 2019 Data for South Gloucestershire .....	120
Figure 61: E4-SG: Heat Opportunities for South Gloucestershire Map .....	123
Figure 62: UK Total Net Greenhouse Gas Emissions (Consumer Transformation) .....	128
Figure 63: Domestic Non-Hybrid Heat Pumps by Scenario in the South West .....	129
Figure 64: Battery Electric Vehicles by Scenario in the South West.....	129
Figure 65: Homes Built Per Year in the South West .....	131
Figure 66: Illustrative Scenario Based Projection Methodology Process .....	132
Figure 67: Breakdown of Projected Energy Consumption (GWh) in South Gloucestershire in 2030. ....	136
Figure 68: Comparison of Current and 2030 Projected Energy Consumption in South Gloucestershire .....	137
Figure 69: Comparison of Energy Generation Required for Each Scenario.....	144
Figure 70: Electricity Generation Comparison of Scenario 1 and South Gloucestershire’s 2030 Consumption .....	145
Figure 71: Technology Breakdown of Scenario 1 by GWh .....	145
Figure 72: Pictogram of Number of Additional 50MW Solar Farms and 5MW Wind Farms Required in Scenario 1 .....	145
Figure 73: Electricity Generation Comparison of Scenario 2 and South Gloucestershire’s 2030 Consumption .....	146

Figure 74: Technology Breakdown of Scenario 2 by GWh .....	146
Figure 75: Pictogram of Number of Additional 50MW Solar Farms and 5MW Wind Farms Required in Scenario 2 .....	146
Figure 76: Electricity Generation Comparison of Scenario 3 and South Gloucestershire's 2030 Consumption .....	147
Figure 77: Technology Breakdown of Scenario 3 by GWh .....	147
Figure 78: Pictogram of Number of Additional 50MW Solar Farms and 5MW Wind Farms Required in Scenario 3 .....	147
Figure 79: Flowchart of Wind Energy Resource Mapping Process .....	197
Figure 80: W1-SG: South Gloucestershire Boundary Map .....	199
Figure 81: W2-SG-1.0MW: Wind Resource for 1.0MW Wind Turbines Constraints – Areas to Exclude from Further Consideration Map .....	201
Figure 82: W3-SG-1.0MW: Remaining Land Parcels for 1.0MW Wind Turbines After Constraining of the Areas that are Excluded from Further Consideration in W2 Map .....	202
Figure 83: W4-SG-1.0MW: Suitable Areas of Land for Installation of 1.0MW Wind Turbines Constrained by Wind Speed Only Map .....	204
Figure 84: W5-SG-1.0MW: Remaining Land Parcels from Resource Map (W3) After Constraining the Unsuitable Areas due to Wind Speed Map (W4) for Installation of 1MW Wind Turbines Map .....	205
Figure 85: W6-SG-1.0MW: Remaining Land Parcels from W5 Map After Constraining Land Slivers, Fire Breaks and Tracks, As Well As Parcels of Land Insufficient to Support a Wind Farm of 5MW or More Based on 1.0 MW Wind Turbines Map .....	207
Figure 86: W7-SG: Combined Wind Search Areas in South Gloucestershire Map .....	210
Figure 87: W8-SG-1.0MW: Wind Resource Other Constraints – to Consider Further Map .....	212
Figure 88: W9-SG: Wind Local Search Areas from W7 Map and Natural England's Wind Impact Risk Zones (IRZs) in South Gloucestershire Map.....	213
Figure 89: W10-SG: Wind Local Search Areas from W7 Map and Areas of Outstanding Natural Beauty (AONB) in South Gloucestershire Map.....	213
Figure 90: W11-SG: Wind Local Search Areas from W7 Map and Flood Zones in South Gloucestershire Map .....	214
Figure 91: W12-SG: Wind Local Search Areas from W7 Map and Green Belt Area in South Gloucestershire Map .....	214
Figure 92: W13-SG-1.0MW: Wind Local Search Areas for 1.0MW Turbines from W6 Map and MOD, NATS and Aviation Safeguarded Zones.....	216
Figure 93 W14-SG: Combined Wind Search Areas and Conservation Areas (Heritage) in South Gloucestershire .....	217
Figure 94: W15-SG-1.0MW: Buffer Zone for Wind Local Search Areas from 1.0MW Turbines Map .	218
Figure 95: SAs Proximity to Grid and Grid Capacity Ranking Key (Refer to map W16 in the Accompanying Document 'South Gloucestershire RERAS – Maps') .....	220
Figure 96: W16-SG-1.0MW: 1.0MW Wind Search Areas and Grid Connection in South Gloucestershire Map .....	221
Figure 97 Steps Taken in Landscape Sensitivity Study for Wind Farm Search Areas .....	222
Figure 98: W17-SG-1MW: Wind Local Search Areas for 1 MW Wind Turbines from W6 map and Landscape Sensitivity Results in Band D (101 to 120) in South Gloucestershire Map .....	224
Figure 99: Flowchart Solar PV Farm Mapping Process.....	230
Figure 100: South Gloucestershire Boundary Map.....	231
Figure 101: S2-SG: Solar PV Resource Constraints - Areas to Exclude from Further Consideration Map .....	233
Figure 102: S3-SG: Remaining Land Parcels After Constraining of the Areas that are Excluded from Further Consideration in S2 Map .....	234
Figure 103: S4-SG: Suitable Areas of Land for Installation of Solar PV Constrained by Land Orientation and Inclination Only Map .....	235
Figure 104: S5-SG: Remaining Land Parcels from Resource Map (S3) After Constraining the Unsuitable Areas due to Land Orientation and Inclination Map .....	236
Figure 105: S6-SG: Remaining Land Parcels After Constraining Land Slivers, Fire Breaks and Tracks, As Well As Parcels of Land Insufficient to Support a Solar PV Farm of 5MW or More Map .....	237
Figure 106: S7-SG: Solar PV Search Areas in South Gloucestershire Map .....	239
Figure 107: S8-SG: Solar PV Resource Other Constraints – to Consider Further Map.....	240
Figure 108: S9-SG: Solar Local Search Areas from S7 Map and Agricultural Land Grade 1 and 2 in South Gloucestershire Map.....	242
Figure 109: S10-SG: Solar Local Search Areas from S7 Map and Natural England's Solar Impact Risk Zones (IRZs) in South Gloucestershire Map.....	242

Figure 110: S11-SG: Solar Local Search Areas from S7 Map and Areas of Outstanding Natural Beauty (AONB) in South Gloucestershire Map .....	243
Figure 111: S12-SG: Solar Local Search Areas from S7 Map and Flood Zones in South Gloucestershire Map .....	243
Figure 112: S13-SG: Solar Local Search Areas from S7 Map and Green Belt Area in South Gloucestershire Map .....	244
Figure 113: S14-SG: Solar PV Search Areas and Conservation Areas (Heritage) in South Gloucestershire Map .....	244
Figure 114: S15-SG: Pipeline Ground Mounted Solar PV Projects and Local Search Areas in South Gloucestershire Map .....	247
Figure 115: SAs Proximity to Grid and Grid Capacity Ranking Key (Refer to map S16 in the Accompanying Document 'South Gloucestershire RERAS – Maps') .....	248
Figure 116: S16-SG: 50MW Solar PV Search Areas and Grid Connection in South Gloucestershire Map .....	249
Figure 117 Steps Taken in Landscape Sensitivity Study for Solar PV Farm Search Areas.....	250
Figure 118: S17-SG-Band A: Solar Local Search Areas from S6 Map and Landscape Sensitivity Results in Band A (≤5ha) in South Gloucestershire Map .....	252
Figure 119: Flowchart of Energy Crop Mapping Process .....	256
Figure 120: B1-SG: Potential Biomass Resource Map (Grade 4 Agricultural Land) Map .....	257
Figure 121: B2-SG: Biomass Resource Constraints – Areas to Exclude from Further Consideration Map .....	258
Figure 122: B3-SG: Remaining Biomass Resource (Grade 4 Agricultural Land) After Constraining of Ancient and Broadleaved Woodlands, Primary Heritage and Ecological Constraints and Existing and Consented Renewable Generation Installations Map.....	259
Figure 123: UK 2019 and Projected Annual Residential Energy Consumption (for heat appliances) in the UK .....	274
Figure 124: UK 2019 and Projected Annual End Consumer Energy Consumption in the UK.....	275
Figure 125: UK 2019 and Projected Annual Industrial and Commercial Energy Consumption in 2050 <sup>320</sup> .....	275
Figure 126: UK Total Annual Consumption for Road Transport in 2050 <sup>320</sup> .....	275
Figure 127: Comparison of 2030 Electricity Generation in this Option and South Gloucestershire's 2030 Consumption .....	282
Figure 128: 2030 Energy Generation by Technology Breakdown in this Option - GWh.....	282
Figure 129: Pictogram of Number of Additional 50MW Solar Farms and 5MW Wind Farms Required in this Option .....	282

## Tables

Table 1: Current and Projected Energy Consumption (GWh) in South Gloucestershire .....	27
Table 2: Summary of Energy from Waste in South Gloucestershire.....	31
Table 3: Current and Maximum Theoretical Stand-Alone Renewable Electric Generation in South Gloucestershire .....	32
Table 4: Current and Maximum Theoretical Large Scale Renewable Heat Generation in South Gloucestershire .....	32
Table 5: Current Projected Maximum Theoretical Potential from Building Integrated and Non-Domestic Renewable Technologies in South Gloucestershire.....	32
Table 6: Policy and Drivers Summary .....	57
Table 7: Existing Energy Consumption (GWh) in South Gloucestershire (2018) .....	61
Table 8: Existing Installed Capacity of Renewable Energy Generators in South GloucestershireT .....	66
Table 9: Wind Turbines Specifications Used Within This Study.....	68
Table 10: Identified Wind SAs in South Gloucestershire and Theoretical Maximum Potential Wind Resource .....	74
Table 11: Individual Identified 1.0MW Wind SAs in South Gloucestershire and Their Theoretical Maximum Potential Installed Capacity .....	75
Table 12: Individual Identified 2.5MW Wind SA's in South Gloucestershire and Their Theoretical Maximum Potential Installed Capacity .....	75
Table 13: Identified Wind SAs in South Gloucestershire and Theoretical Maximum Potential Wind Resource .....	77
Table 14: Remaining Land Available for Ground Mounted Solar PV Farms at this Stage and its Potential Total Installed Capacity .....	84

Table 15: Potential Installed Capacity and Energy Generation from the Identified Search Areas for Ground Mounted Solar PV Farms.....	86
Table 16: Remaining Area of SAs After Applying Selected Other Constraints for Illustrative Purposes Only .....	86
Table 17: The Five-Point Scale Landscape Sensitivity Scale .....	90
Table 18: Wind Turbine Development Sizes Considered in the Landscape Sensitivity Assessment ...	91
Table 19: Solar PV Farm Development Sizes Considered in the Landscape Sensitivity Assessment.	91
Table 20: Individual Identified 1.0MW Wind SA's in South Gloucestershire and Their Landscape Sensitivity Levels.....	91
Table 21: Individual Identified 2.5MW Wind SA's in South Gloucestershire and Their Landscape Sensitivity Levels.....	92
Table 22: Total Potential Energy Crop Resource in South Gloucestershire .....	98
Table 23: Total Potential Energy Resource from Wood Fuel in South Gloucestershire.....	99
Table 24: Summary of Energy from Waste .....	103
Table 25: Potential Hydropower Capacity in South Gloucestershire According to Environmental Sensitivity. ....	104
Table 26: Proportion of Potential Sites in South Gloucestershire Outlined as Win-Win Sites .....	105
Table 27: Battery Storage Projects .....	108
Table 28: Domestic Electric Heating by Scenario in the South West.....	129
Table 29: Domestic Thermal Technologies Projections .....	133
Table 30: Projection of Micro Building-Mounted Solar PV and Wind Installations.....	133
Table 31: Projected Energy Consumption (GWh) in South Gloucestershire in 2030 .....	135
Table 32: Capacity Factors for Renewable and Low and Zero Carbon Technologies.....	139
Table 33: Maximum Theoretical Potential Renewable Energy Resource and Generation in South Gloucestershire in 2030 (Excluding Existing Installations and Heat Delivered via Electric Heating Systems). ....	140
Table 34: Maximum Potential Renewable Energy Generation in South Gloucestershire in 2030 (Excluding Heat Delivered via Electric Heating Systems) .....	141
Table 35: DFES Technology Projection Breakdown (See Appendix R for More Details).....	145
Table 36: Electricity Generation Potential from New Wind and Solar Farms in Scenario 2 .....	146
Table 37: Electricity Generation Potential from New Wind and Solar Farms in Scenario 3 .....	147
Table 38: Recommended Policy Approaches Relating to Scenarios for NZC (SC).....	154
Table 39: Recommended Policy Approaches Relating to Wind Farms (WF) .....	155
Table 40: Recommended Policy Approaches Relating to Solar PV Farms (SF) .....	159
Table 41: Recommended Policy Approaches Relating to Energy Storage (ES).....	161
Table 42: Recommended Policy Approaches Relating to District Heating Networks (DH).....	163
Table 43: Recommended Policy Approaches Relating to Biomass (BM) .....	165
Table 44: Wind Turbines Specifications Used Within This Study.....	198
Table 45: Wind Turbine Noise Buffers and Topple Distances .....	200
Table 46: Remaining Land Available for Wind Turbines at this Stage of the Assessment and Potential Total Installed Capacity Based on the Available Area .....	203
Table 47: Wind Resource Based on Wind Speed in South Gloucestershire .....	205
Table 48: Remaining Land Available for Wind Turbines at this Stage of the Assessment and Potential Total Installed Capacity Based on the Available Area .....	206
Table 49: Identified Wind SAs in South Gloucestershire and Theoretical Maximum Potential Wind Resource .....	208
Table 50: Individual Identified 1.0MW Wind SA's in South Gloucestershire and Their Theoretical Maximum Potential Installed Capacity .....	208
Table 51: Individual Identified 2.5MW Wind SA's in South Gloucestershire and Their Theoretical Maximum Potential Installed Capacity .....	208
Table 52: Remaining Area of SAs After Applying Selected Other Constraints for Illustrative Purposes Only .....	215
Table 53: Repowering Capacity of the Existing Wind Farm in South Gloucestershire .....	219
Table 54: The Five-Point Scale Landscape Sensitivity Scale .....	223
Table 55: Wind Turbine Development Sizes Considered in the Landscape Sensitivity Assessment .	223
Table 56: Individual Identified 1.0MW Wind SA's in South Gloucestershire and Their Landscape Sensitivity Levels.....	224
Table 57: Individual Identified 2.5MW Wind SA's in South Gloucestershire and Their Landscape Sensitivity Levels.....	224
Table 58: Remaining Land Available for Ground Mounted Solar PV Farms at this Stage of the Assessment and Potential Total Installed Capacity Based on the Available Area .....	234

Table 59: Suitability of Sites for PV Installation at Varying Inclinations.....	235
Table 60: Resource Area for Ground Mounted Solar PV Based on Land Orientation and Inclination Only .....	236
Table 61: Remaining Land Available for Ground Mounted Solar PV Farms at this Stage of the and its Potential Total Installed Capacity .....	236
Table 62: Remaining Land Available for Ground Mounted Solar PV Farms at this Stage and its Potential Total Installed Capacity .....	237
Table 63: Remaining Area of SAs After Applying Selected Additional Constraints for Illustrative Purposes Only.....	245
Table 64: Pipeline Solar PV Projects in South Gloucestershire.....	246
Table 65: The Five-Point Scale Landscape Sensitivity Scale .....	251
Table 66: Solar PV Farm Development Sizes Considered in the Landscape Sensitivity Assessment .....	251
Table 67: Total Potential Energy Crop Resource in South Gloucestershire in 2030.....	260
Table 68: Total Potential Energy Resource from Wood Fuel in South Gloucestershire.....	261
Table 69: Municipal Solid Waste Resource for the South Gloucestershire Area in 2030 .....	266
Table 70: Commercial and Industrial waste resource in South Gloucestershire in 2030.....	268
Table 71: Potential Installed Capacity from Total Available Food Waste Resource in the South Gloucestershire in 2030 .....	269
Table 72: Potential Installed Capacity from Total Available Animal Slurry Resource in the South Gloucestershire in 2030 .....	270
Table 73: Potential Installed Capacity from Poultry Litter in the South Gloucestershire in 2030 .....	271
Table 74: Potential Installed Capacity from Total Available Sewage Sludge Resource in South Gloucestershire in 2030 .....	272
Table 75: Summary of Energy from Waste .....	273
Table 76: UK 2050 Greenhouse Gas Emissions by Category: .....	276
Table 77: Potential Maximum Electricity Generation (GWh).....	282

## Acronyms and Abbreviations

Acronym/ Abbreviation	
AC	Alternating Current
AD	Anaerobic Digestion
AGL	Above Ground Level
AHL	Anchor Heat Load
ALC	Agricultural Land Classification
AONB	Areas of Outstanding Natural Beauty
B&NES	Bath and North East Somerset
BD	Biodegradable
BEIS	Business, Energy and Industrial Strategy Department
BIR	Building Integrated Renewables
C&D	Construction and Demolition
C&I	Commercial and Industrial
CAA	Civil Aviation Authority
CCC	Climate Change Committee
CCHP	Combined Cooling Heating and Power
CCS	Carbon Capture and Storage
CES	Climate Energy Strategy
CF	Capacity Factor
CGS	Clean Grown Strategy
CHP	Combined Heat and Power
CMZ	Constraint Management Zones
CO	Carbon Monoxide
CO <sub>2</sub>	Carbon Dioxide
CS	Core Strategy
DC	Direct Current
DECC	Display Energy Certificates
DECC	Department for Energy and Climate Change
DEFRA	Department for Energy, Food and Rural Affairs
DFES	Distribution Future Energy Scenarios
DHN	District Heating Network
DHW	Domestic Hot Water
DNO	Distribution Network Operator
DPD	Development Planning Document
ECO	Energy Company Obligation
EfW	Energy from Waste
EPC	Energy Performance Certificate
ERF	Energy Recovery Facility



ESCO	Energy Service Company
EU	European Union
FES	Future Energy Scenarios
FiT	Feed-in-Tarif
GI	Green Infrastructure
GIS	Geographic Information System
GW	Gigawatts
HNDU	Heat Network Development Unit
HNIP	Heat Network Investment Project
HWRC	Household Waste Recycling Centres
IRZ	Impact Risk Zones
JWCS	Joint Waste Core Strategy
kW	Kilowatts
LA	Local Authority
LDP	Local Development Plan
LAEP	Local Area Energy Plan
LP	Local Plan
LSOA	Lower Super Output Area
LZC	Low & Zero Carbon
MHCLG	Ministry of Housing, Communities and Local Government
MoD	Ministry of Defence
MSOA	Middle Super Output Area
MSW	Municipal Solid Waste
MW	Megawatts
MWe	Megawatts electrical
MWhe	Megawatt hours electrical
MWht	Megawatt Hours thermal
MWt	Megawatts thermal
NATS	National Air Traffic Service
NDF	National Development Framework
NECP	National Energy and Climate Plan
NIRAB	Nuclear Innovation and Research Advisory Board
NIRO	Nuclear Innovation and Research Office
NNR	National Nature Reserves
NO <sub>x</sub>	Nitrogen Oxide
NP	Neighbourhood Plan
NPPF	National Planning Policy Framework
NPPW	National Planning Policy for Waste
NSC	North Somerset Council
odt	Oven-Dry Tonnes

PD	Permitted Development
PM	Particulate Matter
PPS	Planning Policy Statement
PSP	Policies, Sites and Places
PV	Photovoltaic
REGO	Renewables Energy Guarantees Origin
REPD	Renewable Energy Planning Database
RERAS	Renewable Energy Resource Assessment Study
RES	Renewable Energy Strategy
RHI	Renewable Heat Incentive
RIGS	Regionally Important Geological Sites
RO	Renewables Obligation
RSS	Regional Spatial Strategy
SA	Search Area
SAC	Special Areas of Conservation
SAM	Scheduled Ancient Monument
SDS	Spatial Development Strategy
SEG	Smart Export Guarantee
SG	South Gloucestershire
SH	Space Heating
SMR	Steam Methane Reforming
SPA	Special Protection Areas
SPD	Supplementary Planning Document
SPG	Supplementary Planning Guide
SSSI	Sites of Special Scientific Interest
UK	United Kingdom
UKAEA	UK Atomic Energy Authority
WDI	Waste Data Interrogator
WECA	West of England Combined Authority
WPD	Western Power Distribution

## Report – Summary

### Introduction

South Gloucestershire Council, working with its partners (Bath and North East Somerset Council, North Somerset Council and the West of England Combined Authority), has commissioned AECOM to undertake a Renewable Energy Resource Assessment Study (RERAS) as an evidence base to inform new Local Plans and a variety of future workstreams requiring the consideration of different renewable energy resources. The study informs decisions on policies that support and facilitate the deployment of renewable and low and zero-carbon energy systems. The RERAS consists of a bottom-up assessment of the potential for the deployment of various renewable and low and zero carbon energy technologies at different scales and in different locations across South Gloucestershire.

### Why is this Renewable Energy Resource Assessment Study Important?

#### Climate Change<sup>1</sup>

Climate change is the variation of temperature and weather patterns over time. A significant change in temperature and weather patterns can lead to environmental changes that substantially impact the way we live. The current Global climate emergency relates to a sustained increase in average temperature, known as 'global warming'.

The Earth's average temperature has increased by approximately 1°C (1.8°F) in the last century. Although this seems like a small increase, this has had a significant impact on the warming of oceans, melting of polar ice and glaciers, rising sea levels and extreme weather events. Changes such as these could lead to shortages in access to fresh water, significant implications for the food chain, deaths from extreme weather conditions and extinction for many species (as their habitats will be changing faster than they can adapt to).



Figure 1: Image of Sea Ice

#### How Is the Earth's Temperature Rising?<sup>2</sup>

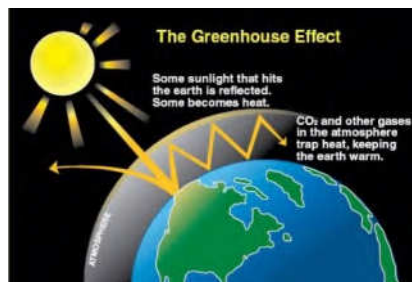

Figure 2: The Greenhouse Effect

The Earth is warmed by a natural process called the 'greenhouse effect'. Radiation from the sun (known as solar radiation) reaches the Earth's atmosphere and is absorbed by the oceans and land, warming the Earth. The Earth then radiates heat back towards space. Greenhouse gases in the atmosphere (such as carbon dioxide and methane) prevent some of this heat from escaping into space, keeping the Earth warm. However, as we produce more greenhouse gases, more heat is being trapped, increasing the Earth's temperature, leading to global warming.

#### What Are We Doing to Prevent This?

Addressing climate change is an issue that is now at the forefront of public and government consciousness, and there are new, fast-changing policies emerging.

Climate change is not a new issue and has been a concern for many years. In 1998 the Kyoto Protocol was adopted, committing over 190 countries to limit and reduce their greenhouse gas emissions to prevent dangerous anthropogenic interference with the climate system. The Paris Agreement was adopted in 2016 with the global action plan to limit the effects of climate change by limiting global warming to well below 2°C and pursuing efforts to limit it to 1.5°C. In 2008, the UK Climate Change Act set a legally binding target to reduce the UK carbon emissions by 80% compared to the 1990 baseline by 2050. Following recommendations from the Climate Change Committee (CCC), this target was updated to a reduction in carbon emissions by 100% compared to the 1990 baseline by 2050, or in other words, 'net zero'. Since then, other policies and strategies have been

<sup>1</sup> Image from <https://aecom.assetbank-server.com/assetbank-aecom/action/viewHome>

<sup>2</sup> Image from <https://www.eden.gov.uk/your-environment/zero-carbon-eden/climate-change/>

published to help achieve this net zero target. The UK Renewable Energy Roadmap sets the path for the delivery of these targets. The first six-carbon budgets, leading to 2037, have been set in law. The first two budgets have been met (2008-12, 25% and 2013-2017, 31%), and the third is very likely to be met (2018-22, 37%). The remaining budget targets are as follows:

- Meeting the fourth carbon budget (2023-2027) will require that emissions be reduced by 50% on 1990 levels in 2025;
- Meeting the fifth carbon budget (2028-2032) will require that emissions be reduced by 57% on 1990 levels in 2030; and
- Meeting the sixth carbon budget (2033-2037) will require that emissions reduce by 78% on 1990 levels in 2035<sup>3</sup>.

### South Gloucestershire’s Input into Reducing Carbon Emissions

In July 2019, South Gloucestershire Council declared a climate emergency. Subsequently, a Climate Emergency Strategy was developed in which the council pledges:



For South Gloucestershire to become carbon neutral by 2030.



To maximise the generation of renewable energy from installations located within South Gloucestershire.



To ensure South Gloucestershire is prepared for the local impacts of a changing climate.



To ensure that nature in the local area is more protected, connected and healthy and that biodiversity is increased.



To plant trees across South Gloucestershire by 2030 to double tree canopy cover.

In order to meet these aims, a Climate Emergency Action Plan will be set out every year until 2030.

This RERAS includes an assessment of the potential for renewable energy generation across South Gloucestershire, highlighting the extent of the change required and informing considerations for future policies to ensure that the 2030 aims are achievable.

<sup>3</sup> The Sixth Carbon Budget limits the volume of greenhouse gases emitted over the 5 year period from 2033 to 2037, this includes a target for 2035.

## Technologies

### Defining the Units Used in this RERAS

#### **ELECTRICITY/ HEAT OUTPUT**

kilowatts (kW);  
megawatts (MW), which is one thousand kW; or  
gigawatts (GW), which is a thousand MW.

These are a measure of the electricity or heat output being generated (or used) at any given moment in time. When it is running at full load, the maximum output of a generator is referred to as its installed capacity or rated power/heat output.

Energy, on the other hand, is the product of power and time. It has kWh units (the h stands for “hour”) or MWh, or GWh.

#### **ELECTRICITY/ HEAT OUTPUT**

kilowatt hour (kWh);  
megawatt hour (MWh), which is one thousand kWh; or  
gigawatt hour (GWh), which is a thousand MW.

As an example, if a 2MW wind turbine ran at full power for 1 hour, it would have generated  $2 \times 1 = 2$  MWh of energy. If it ran at full power for one day (24 hours), it would have generated  $2 \times 24 = 48$  MWh.

This distinction is essential because in carrying out the RERAS, certain assumptions have been made to calculate both the potential installed capacity (or maximum power output) of different technologies and the potential annual energy output.

### Electricity vs Heat Output

It is essential to distinguish whether a generator produces electricity or heat to avoid confusion in terms of the units used. This is because some renewable energy fuels (i.e. biomass) can be used to produce either heat only or electricity and heat simultaneously when used in a CHP plant.

It is also important to be able to distinguish between renewable electricity targets and renewable heat targets.

The suffix “e” is added to denote electricity power or energy output, e.g. MWe, or MWhe

The suffix “t” is used (for “thermal”), to denote heat output, e.g. MWt, or MWht.

### Technologies Addressed in this Study<sup>4</sup>

The following technologies are covered in this RERAS:

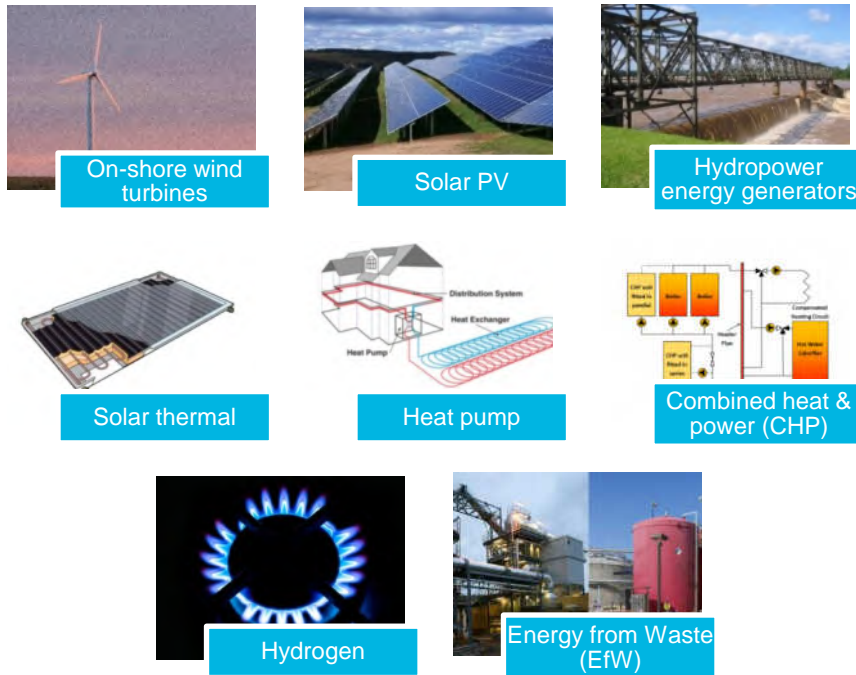

#### On-Shore Wind Turbines



Figure 3: Wind Farm

On-shore wind power is a ‘mature technology’ that is being used for electricity generation worldwide. Most turbines are currently designed using a horizontal axis three-blade rotor system mounted on a steel mast. The blades drive a generator either directly or via a gearbox (generally for larger machines) to produce electricity. Turbines can produce electricity without operational carbon dioxide emissions.

#### Solar Photovoltaic

Solar Photovoltaic (PV) systems use solar cells to generate electricity directly from sunlight. The solar cells are typically packaged together into panels or other modular forms. The technology is technically well-proven, with numerous systems installed around the world, ranging from small domestic systems (circa 3.5 kW) to large PV farms (several MWs). PV technology is common in the UK, and new technologies such as solar tiles, which can be integrated into new buildings or refurbishments alongside conventional roofing tiles, are becoming more widely available.



Figure 4: Ground Mounted Solar PV Array

<sup>4</sup> Wind Turbine, Solar PV, Hydropower Images from: <https://aecom.assetbank-server.com/assetbank-aecom/action/viewHome>  
Solar thermal Image:

[https://assets.publishing.service.gov.uk/government/uploads/system/uploads/attachment\\_data/file/879765/Solar\\_Thermal\\_TIL\\_-\\_April\\_2020.pdf](https://assets.publishing.service.gov.uk/government/uploads/system/uploads/attachment_data/file/879765/Solar_Thermal_TIL_-_April_2020.pdf)

Heat pump Image: <https://www.newcastle.gov.uk/services/environment-and-waste/energy-services/electrification-heat/electrification-heat-heat-pump>

Combined heat & power Image:

[https://assets.publishing.service.gov.uk/government/uploads/system/uploads/attachment\\_data/file/961492/Part\\_2\\_CHP\\_Technologies\\_BEIS\\_v03.pdf](https://assets.publishing.service.gov.uk/government/uploads/system/uploads/attachment_data/file/961492/Part_2_CHP_Technologies_BEIS_v03.pdf)

Hydrogen Image:

[https://assets.publishing.service.gov.uk/government/uploads/system/uploads/attachment\\_data/file/845658/energy-innovation-needs-assessment-hydrogen-fuel-cells.pdf](https://assets.publishing.service.gov.uk/government/uploads/system/uploads/attachment_data/file/845658/energy-innovation-needs-assessment-hydrogen-fuel-cells.pdf)

## Hydropower Energy Generators

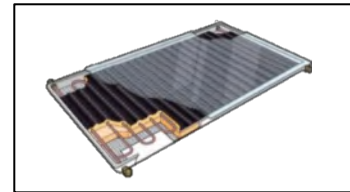

**Figure 5: Hydropower Energy Generator**

Hydropower is the energy derived from flowing water. This can be from rivers or man-made installations, where water flows from a high-level reservoir down through a tunnel and away from a dam. The water drives a turbine connected to an electrical generator, with the energy generated proportional to the volume of water and vertical drop or head.

## Solar Thermal

Solar thermal systems use solar collectors, usually placed on the roof of a building, to preheat water for use in hot water applications in buildings. A conventional boiler or immersion heater can be used to increase the temperature of the water or to provide hot water when solar energy is unavailable



**Figure 6: Diagram of a Solar Thermal Collector**

## Heat Pumps

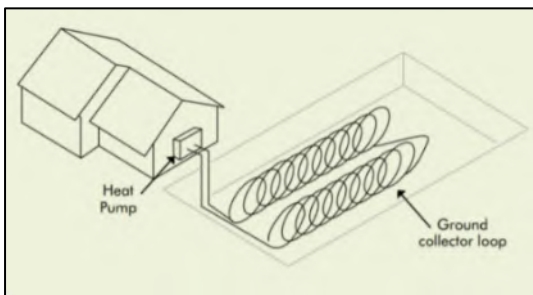
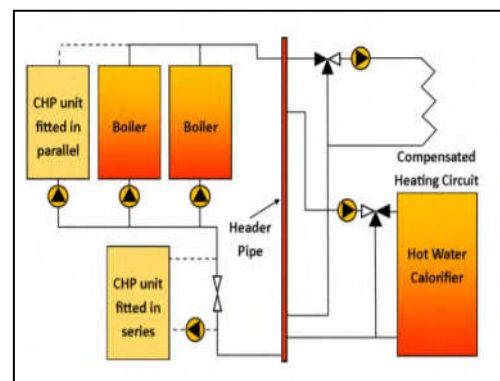

**Figure 7: Diagram of a Ground Source Heat Pump System**

Heat pump systems absorb the solar heat energy stored in the ground, water bodies, or air into a fluid at low temperature. The fluid is then passed through a compressor to increase its temperature to be used for heating purposes. Although the heat pumps extract renewable heat from the environment, they use electricity as fuel, which may or may not come from renewable sources. However, one of the significant advantages of heat pumps compared to other heat delivery systems is that the heat output is greater (typically 2 to 3 times) than the electricity input, making them an energy-efficient heating technology.

## Combined Heat and Power

A Combined Heat and Power (CHP) plant is an installation where there is the simultaneous generation of usable heat and power. This improves the overall energy utilisation of a given fuel compared with the traditional stand-alone boilers. Fuel for the CHPs can come from various sources, including biomass<sup>5</sup>, energy from waste (incineration), anaerobic digestion<sup>6</sup> and landfill gas<sup>7</sup>.



**Figure 8: Diagram of a Combined Heat and Power System**

<sup>5</sup> A broad term covering all organic material and can be generally defined as material of recent biological origin, derived from plant or animal matter.

<sup>6</sup> A process which produces a biogas with a high methane content which can be captured and burned to produce heat and/or electricity and utilisation as a transport fuel.

<sup>7</sup> Landfill gas is a natural by-product of the decomposition of organic material in landfills. This gas can be collected and used as an energy source, usually for electricity generation.

## Energy Storage – Hydrogen



**Figure 9: Diagram of a H<sub>2</sub> Molecule**

Hydrogen is not a renewable energy source but rather an energy carrier for which renewable energy sources can be used to produce. Hydrogen can be used as a heating fuel in homes or industries, in large scale power generation or as a fuel for hydrogen fuel cell vehicles, especially for heavy-duty vehicles. There are three main ways of producing hydrogen which are listed below; each production method has a descriptive colour.

### Grey Hydrogen

Grey hydrogen is made using fossil fuels. This process emits CO<sub>2</sub> into the atmosphere.

### Blue Hydrogen

Blue hydrogen is made using fossil fuels, but carbon capture technology is used to prevent the emission of the CO<sub>2</sub> produced.

### Green Hydrogen

Green hydrogen is the cleanest, producing zero carbon emissions. Green hydrogen is produced via electrolysis powered by renewable energy.

Only the use of green hydrogen is considered in this RERAS.

## Methodology

This RERAS is compiled in alignment with government policy as set out in the Energy Renewable and Low-Carbon Energy Capacity Methodology for the English Regions<sup>8</sup> in alignment with the National Planning Policy Framework. This RERAS is a 'bottom up' study of the available resource for renewable energy generation within the South Gloucestershire area, considering practical constraints. Using informed assumptions about the technologies likely to be employed for converting resources, energy generation figures have been produced for use in considering planning policies with a view to meeting South Gloucestershire's carbon neutral aims by 2030.

Assumptions and data used in producing this RERAS have been sought from established sources, and these are either referenced as footnotes to the text or appropriately appended. Where there are no established sources, assumptions have been made based on AECOM's best estimate and through discussion with South Gloucestershire Council and its partners.

## Potential Installed Capacity

Maps have been produced to enable spatial identification and provide a visual representation of the potential renewable energy opportunities. These maps were produced using Geographic Information Systems (GIS), whereby overlaying multiple datasets enabled a reveal of opportunities through the removal of developmental primary constraint layers. The 'primary' constraints data were overlaid in stages and are related to resource, technological characteristics, safety, protection of heritage and the environment and other categories. The areas covered by these 'primary' constraints were then removed from further consideration. On completion of the constraining exercise, the maximum theoretical installed capacity is established along with maximum renewable energy generation potential.

The decision was taken to consider 'other' constraints, and the impact they might have on the maximum potential generation, through the Local Plan process alongside issues relating to landscape sensitivity and grid capacity and other objectives. However, additional maps are presented in the RERAS to provide information about the locations of these 'other' constraints.

Projections about future energy generation potential to 2030 are also included in the report for technologies that do not lend themselves to spatial analysis but are more dependent upon statistics (e.g. municipal solid waste and food waste).

<sup>8</sup>[https://assets.publishing.service.gov.uk/government/uploads/system/uploads/attachment\\_data/file/226175/renewable\\_and\\_low\\_carbon\\_energy\\_capacity\\_methodology\\_jan2010.pdf](https://assets.publishing.service.gov.uk/government/uploads/system/uploads/attachment_data/file/226175/renewable_and_low_carbon_energy_capacity_methodology_jan2010.pdf)



Maps showing the Search Areas (SAs) established for potential wind and solar PV farms after this constraining exercise are shown in and below. Higher resolution versions of these maps are contained in the accompanying document 'South Gloucestershire RERAS – Maps'.

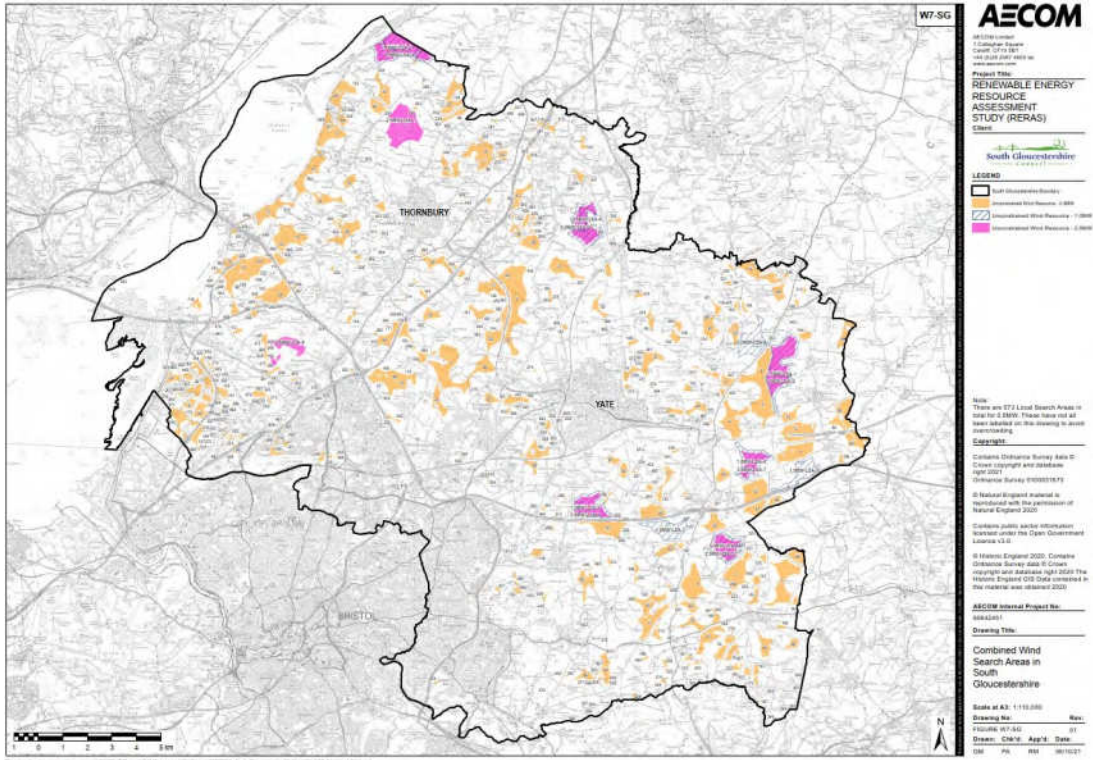

Figure 10: W7-SG: Combined Wind Search Areas in South Gloucestershire Map

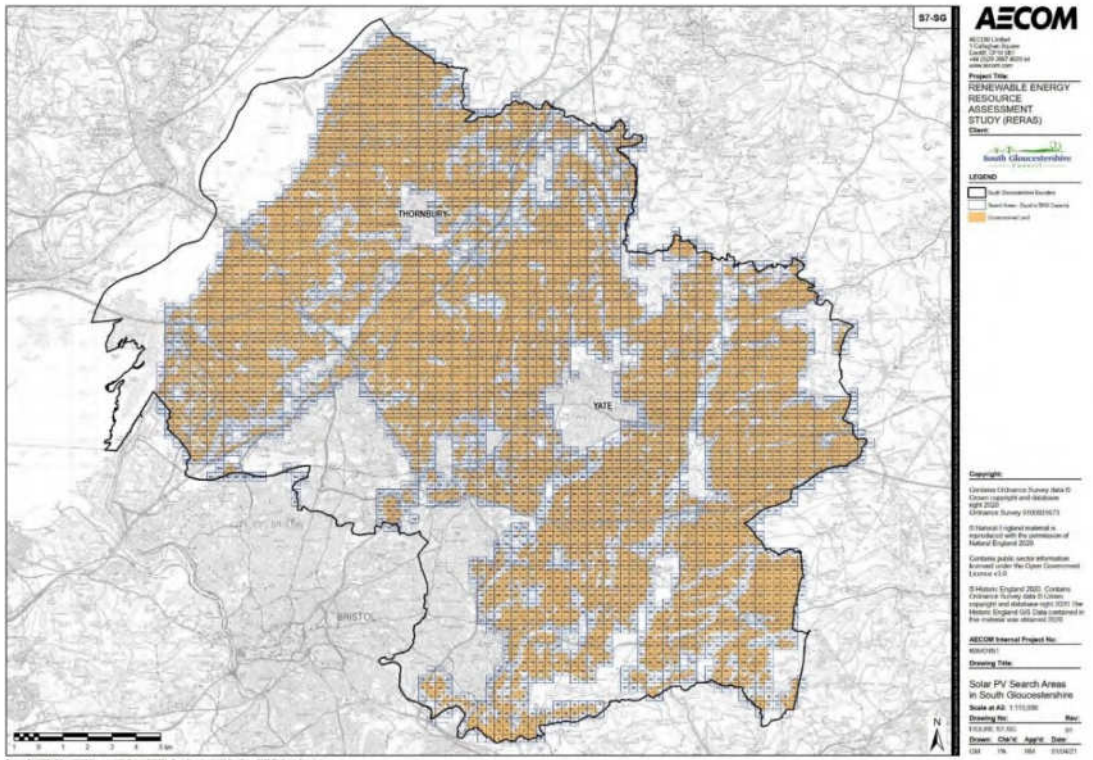

Figure 11: S7-SG: Solar PV Search Areas in South Gloucestershire Map

## Future Energy Consumption

In order to understand different scenarios for renewable energy generation going forward, it has been necessary to understand the level of likely energy consumption in the future. It is projected that electricity will play a more significant role in heating our homes and other buildings as well as fuelling our transport.

Every year the National Grid Electricity Systems Operator (ESO) produce their Future Energy Scenarios (FES). These are in-depth analyses of four future scenarios for the energy system. Each scenario considers the amount of energy that may be needed and where it could come from. The 2020 FES have been updated to reflect the UK Government 2050 net zero targets. The four scenarios are described below:

### 1. Steady Progression

- Low levels of decarbonisation and societal change.
- Not compliant with the 2050 net zero emissions target.

### 2. System Transformation

- High level of decarbonisation with lower societal change. Larger, more centralised solutions are developed. This scenario has the highest levels of hydrogen deployment.

### 3. Consumer Transformation

- High levels of decarbonisation and societal change. Consumers adopt new technologies rapidly, and more decentralised solutions are developed. This scenario has significant electrification of domestic heat.

### 4. Leading the Way

- Very high levels of decarbonisation and societal change. Consumers adopt new technologies rapidly, and a mix of solutions are developed. This scenario aims for the “fastest credible” decarbonisation pathway

Western Power Distribution (WPD) has used the National Grid ESO FES as a framework to make projections concerning changes in consumption, storage and distributed generation, including electrified transport and heat across the South West of England; these are the Distribution Future Energy Scenarios (DFES).

Throughout this RERAS, the Consumer Transformation scenario is utilised. The Consumer Transformation scenario assumes that the UK net zero target is met with measures that have a greater impact on consumers and is driven through consumer engagement. This includes extensive changes to improve the energy efficiencies of homes as well as a higher level of renewable energy generation technology integrated into these homes (referred to in this report as ‘Building Integrated Renewables’).

As South Gloucestershire aims to be net zero by 2030, 20 years earlier than the UK target, the decarbonisation projections of DFES have been updated to reflect this. An adjustment was made to bring forward the projected energy consumption and installed capacity of renewables technologies to 2030, as well as increase the projected use of electric vehicles, but not energy consumption of new development between 2030 and 2050. This is because FES housing and population projections are consistent across their scenarios up to 2050, and therefore, the population growth has not been accelerated from 2050 to 2030 in this RERAS.<sup>9</sup>

<sup>9</sup> FES assumes that the population of Great Britain reaches 68.6 million and that the number of homes grows to 31.9 million by 2050 in all of our scenarios. These compare to a population of 64.9 million and 28.3 million homes in 2019.  
<https://www.nationalgrideso.com/document/173796/download>

## Baseline Energy Consumption vs Future Consumption

The current energy consumption within South Gloucestershire is 7,069GWh, and the projected future consumption in 2030 is 3,499GWh. The 2030 projected consumption is much lower than the current consumption mainly due to efficiency improvements of electric systems and energy efficiency improvements to homes. A breakdown of the data is shown in Figure 12 below.

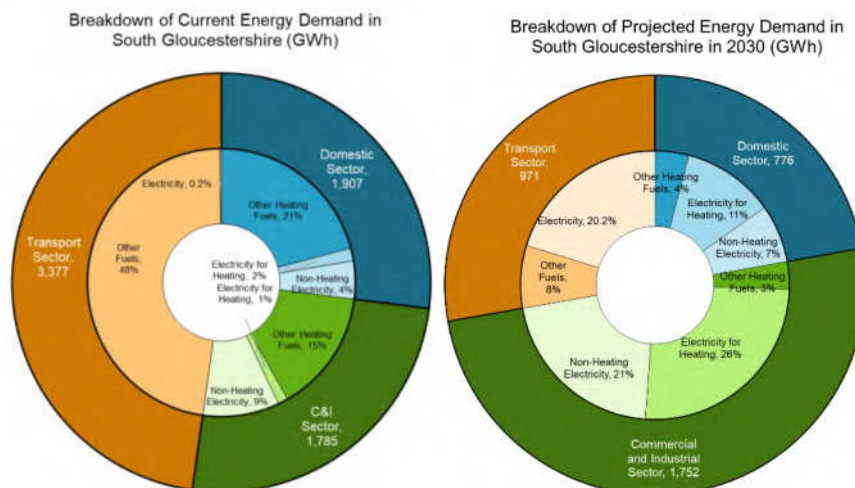

**Figure 12: Breakdown of Current and Projected 2030 Energy Consumption in South Gloucestershire**

A more detailed breakdown of the current and future energy consumption can be seen in Table 1.

**Table 1: Current and Projected Energy Consumption (GWh) in South Gloucestershire**

Fuel Type	Use	Details	Current Energy Consumption (GWh)	2030 Energy Consumption (GWh)
Fossil Fuels and Renewables Other Than Electricity	Heating	Domestic Buildings Fossil Fuels and Renewables Energy Consumption for Heating	1,473.0	141.7
Electricity	Heating	Domestic Buildings Electricity Consumption for Heating	111.4	390.3
Electricity	Non-Heating Electricity in Buildings	Domestic Buildings Non-Heating Electricity Consumption	323.0	243.9
Fossil Fuels and Renewables Other Than Electricity	Heating	Commercial and Industrial Buildings Fossil Fuels and Renewables Energy Consumption for Heating	1,045.1	116.6
Electricity	Heating	Commercial and Industrial Buildings Electricity Consumption for Heating	86.3	896.6
Electricity	Non-Heating Electricity in Buildings	Commercial and Industrial Buildings Non-Heating Electricity Consumption	653.2	738.6
Fossil Fuels and Renewables Other Than Electricity	Transport Sector	Transport Sector Other Fuels Consumption	3,365.0	263.8
Electricity	Transport Sector	Transport Sector Electricity Consumption	11.6	707.2
<b>Total Heat Demand (Including Electrical Heating Consumption)</b>			<b>2,715.8</b>	<b>1,545.3</b>
<b>Total Electricity Consumption (Including Electrical Heating Consumption and Transport Sector Electricity Consumption)</b>			<b>1,185.6</b>	<b>2,977.6</b>
<b>Total Transport Sector Energy Consumption</b>			<b>3,376.6</b>	<b>970.9</b>
<b>Total Energy Consumption</b>			<b>7,068.6</b>	<b>3,498.7</b>

The installed capacity of existing renewable energy technologies has been broken down into solar PV, onshore wind, hydropower, waste incineration, landfill gas and large-scale biomass for the electricity generators and waste incineration, domestic heat pumps, domestic biomass, domestic solar thermal and non-domestic renewable technologies for heat generators. The split can be seen below in Figure 13 and Figure 14.

### Existing Installed Capacity of Renewable Electricity Generators in South Gloucestershire in 2020 (MWe)

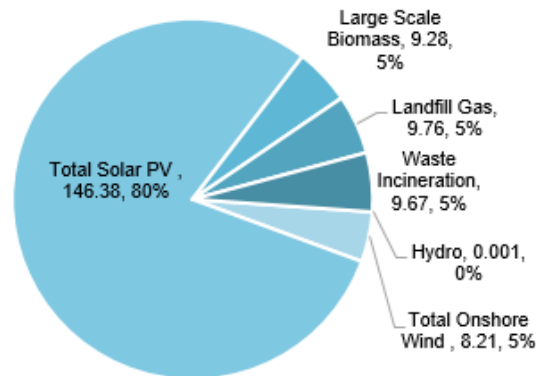

**Figure 13: Existing Installed Capacity of Renewable Electricity Generators in South Gloucestershire in 2020**

### Existing Installed Capacity of Renewable Heat Generators in South Gloucestershire in 2020 (MWth)

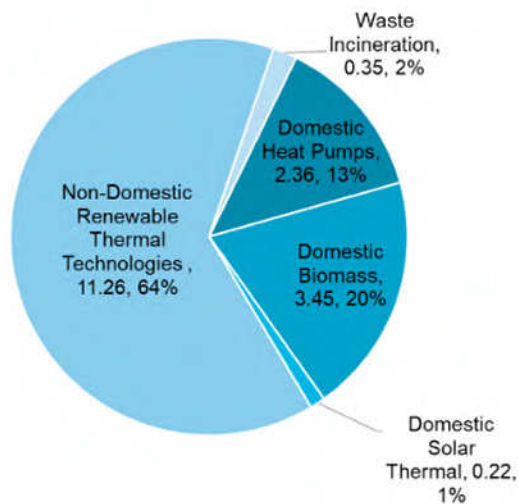

**Figure 14: Existing Installed Capacity of Renewable Heat Generators in South Gloucestershire in 2020**

There is currently enough installed capacity for electricity generation to meet the equivalent of 28% of local demand. A low proportion of the existing requirement for heat is currently met from renewables, being the equivalent of 1% of local demand.

## Results<sup>10</sup> - Theoretical Maximum Available Resource

The figures and table below provide an overview of the potential additional capacity identified in South Gloucestershire.

### STAND-ALONE WIND FARMS



For 1MW wind turbines, there is a total theoretical potential installed capacity of 86.13MW equating to 187.54GWh of electricity generation.

For 2.5MW wind turbines there is a total theoretical potential installed capacity of 73.17MW equating to 159.26GWh of electricity generation (the suitable areas for 2.5MW Turbines overlap with the 1.0MW areas and cannot be added together.)

573 additional small land parcels for 500kW turbines installations have been identified with a theoretical potential installed capacity of 286.5MW equating to 623.60GWh of electricity generation.

### STAND-ALONE SOLAR PV



There is a total theoretical potential installed capacity of 11,184.2MW equating to 9,797GWh of electricity generation.

### BIOMASS: ENERGY CROP



Based on our assumptions, the total usable area of land for energy crops across South Gloucestershire is 2.90 km<sup>2</sup>.

Based on combusting energy crops in combined heat and power engines and utilising the heat, there is a total theoretical potential installed capacity across South Gloucestershire of 0.53MWe and 1.06MWt, which, for comparison, is equal to supplying energy to 46 typical primary schools annually.

<sup>10</sup> Wind Turbine, Solar PV, Biomass Energy Crops, Municipal Solid Waste, Animal Slurry, Hydropower Images from:

<https://aecom.assetbank-server.com/assetbank-aecom/action/viewHome>

Wood Fuel: [https://www.forestresearch.gov.uk/documents/2046/Woodfuel\\_meets\\_the\\_challenge.pdf](https://www.forestresearch.gov.uk/documents/2046/Woodfuel_meets_the_challenge.pdf)

C&I Waste:

[https://assets.publishing.service.gov.uk/government/uploads/system/uploads/attachment\\_data/file/221036/pb13889-incineration-municipal-waste.pdf](https://assets.publishing.service.gov.uk/government/uploads/system/uploads/attachment_data/file/221036/pb13889-incineration-municipal-waste.pdf)

Food Waste: <https://www.northlincs.gov.uk/news/fight-climate-change-with-food-waste-action-week/>

Poultry Litter: [https://assets.publishing.service.gov.uk/government/uploads/system/uploads/attachment\\_data/file/732227/code-of-practice-welfare-of-laying-hens-pullets.pdf](https://assets.publishing.service.gov.uk/government/uploads/system/uploads/attachment_data/file/732227/code-of-practice-welfare-of-laying-hens-pullets.pdf)

## BIOMASS: WOOD FUEL

The total area of woodland within the National Forestry Inventory in South Gloucestershire (all woodland 0.5 hectares and over across South Gloucestershire) is 38.97km<sup>2</sup> which could result in a total wood fuel yield from management activities of 7,794odt per annum across South Gloucestershire.

Utilising this wood fuel in biomass boilers would result in a maximum theoretical potential installed capacity from across South Gloucestershire of 11.8MWt, equivalent to supplying energy to 168 typical primary schools annually.



## HYDROPOWER



Additionally, the potential for hydropower generation across South Gloucestershire has been assessed. Since the majority of the potential hydropower sites are located within high sensitivity areas, it has been deemed that no further significant practical potential hydroelectric capacity is available in South Gloucestershire.

## Energy from Waste



See Table 2 below for a summary of EfW potential. It should be noted that, although there is potential generation from energy from waste, a majority of this resource is currently either transported outside of South Gloucestershire or indications are that many of the economic opportunities have already been exploited. There is enough resource to justify the use of animal slurry and poultry litter resources if the two were combined and to utilise sewage sludge for further energy generation. However, the potential resource from other energy from waste resource streams such as food waste, C&I waste etc. were assumed to be part of the existing energy generation in South Gloucestershire or elsewhere.

**Table 2: Summary of Energy from Waste in South Gloucestershire**

Photo	Resource	Technology	Prior to Consideration of the Likelihood of Utilisation for RE Generation		Reason for Adjustment/Change of Technology	Post Consideration of the Likelihood of Utilisation for RE Generation 2030		
			2030 MWe	2030 MWt		Technology	MWe	MWt
	C&I Waste	EfW with CHP	2.02	4.04	It is currently recycled, and the bulk of residual waste is exported to facilities outside South Gloucestershire. Therefore, it is counted as an existing generation elsewhere.	None	-	-
	MSW	EfW with CHP	1.41	2.81	It is currently recycled. Non-recyclable material is exported to Severnside and Viridor energy recovery centres in South Gloucestershire and Bristol, respectively. Therefore, it is counted as existing generation in South Gloucestershire or elsewhere.	None	-	-
	Food Waste	AD with CHP	0.53	0.80	Currently processed in Bristol Avonmouth, in the West of England. Assuming that the existing arrangements remain until 2030, the food waste is already accounted for as existing generation elsewhere.	None	-	-
	Animal Slurry	AD with CHP	0.66	0.99	Combined with Poultry Litter	AD	1.150	1.970
	Poultry Litter	Bespoke plant with CHP	0.49	0.98	Not likely to be enough resource for a bespoke plant. This resource is therefore combined with Animal slurry for AD with CHP above.	None	-	-
	Sewage Sludge	AD with CHP	0.63	0.94		AD	0.63	0.94
	Landfill Gas	Landfill gas recovery engine			There is a 9.76MWe installed capacity; it is assumed that all economic opportunities are exploited and is included within the existing generation.	None		
<b>Potential Installed Capacity</b>			<b>5.74</b>	<b>10.56</b>			<b>1.78</b>	<b>2.91</b>

The following tables outline the current and maximum theoretical potential generation in South Gloucestershire

**Table 3: Current and Maximum Theoretical Stand-Alone Renewable Electric Generation in South Gloucestershire**

Resource	Existing Installed Capacity (MWe)	Maximum Installed Capacity from New Installations (MWe)	Potential Maximum Delivered Energy (GWhe)
Large Scale Wind <sup>11</sup>	8.21	392.49	872.14
Solar PV Farms	124.40	11,184.20	10,968.62
Hydropower	0.001	0.00	0.003
<b>TOTAL</b>	<b>132.61</b>	<b>11,576.69</b>	<b>11,840.76</b>

**Table 4: Current and Maximum Theoretical Large Scale Renewable Heat Generation in South Gloucestershire**

Resource	Existing Installed Capacity		Maximum Installed Capacity from New Installations		Potential Maximum Delivered Energy	
	Electricity (MWe)	Thermal (MWt)	Electricity (MWe)	Thermal (MWt)	Electricity (GWhe)	Thermal (GWht)
Biomass, Energy Crop <sup>12</sup>	9.28	-	-	-	57.86	-
Energy from Waste	9.67	0.35	0.00	0.00	76.24	42.35
Landfill Gas	9.76	-	-	0.00	39.55	-
Other (including food waste, animal slurry, poultry litter and sewage sludge. AD with CHP)	-	-	1.78	2.90	6.77	12.70
<b>TOTAL</b>	<b>28.71</b>	<b>0.35</b>	<b>1.78</b>	<b>2.9</b>	<b>180.42</b>	<b>55.05</b>

**Table 5: Current Projected Maximum Theoretical Potential from Building Integrated and Non-Domestic Renewable Technologies in South Gloucestershire**

Resource	Existing Installed Capacity		Maximum Installed Capacity from New Installations		Potential Maximum Delivered Energy	
	Electricity (MWe)	Thermal (MWt)	Electricity (MWe)	Thermal (MWt)	Electricity (GWhe)	Thermal (GWht)
Projected Building Integrated Wind (<6kW) Turbines	0.017	-	0.07	-	0.08	-
Projected PV-Commercial Rooftop (10kW - 1MW)	9.10	-	68.39	-	67.78	-
Projected PV-Domestic Rooftop (<10kW)	12.88	-	137.94	-	132.12	-
Projected biomass consumption by building integrated biomass boilers in 2030 (domestic)	-	-	-	-	-	5.610
Projected biofuel consumption by building integrated biofuel boiler in 2030 (domestic)	-	-	-	-	-	35.04
Projected heat delivered by solar thermal in 2030 (domestic)	-	-	-	0.16	-	0.28
Non-domestic renewable thermal technologies other than heat pumps <sup>13</sup>	-	9.8	-	-	-	17.14
<b>TOTAL</b>	<b>22.0</b>	<b>9.8</b>	<b>206.4</b>	<b>0.16</b>	<b>199.98</b>	<b>58.07</b>

<sup>11</sup> The potential from 1.0MW and 2.5MW search areas cannot be added together as some of the areas overlap. The maximum capacity in this Figure is taken from 1.0MW search areas plus and additional non-overlapping 2.5MW search areas.

<sup>12</sup> In this RERAS, 45.11GWht of biomass resource has been identified (see Section 8 of the main report) however, these figures only contain uptake based on the DFES and therefore these have not been included in the table.

<sup>13</sup> It has been assumed the majority of new renewable heat installations in non-domestic buildings will be of electric heating. High-grade heat requirements will be met by hydrogen in the C&I setting and therefore hydrogen electrolysis's portion of electricity demand is also calculated and included.



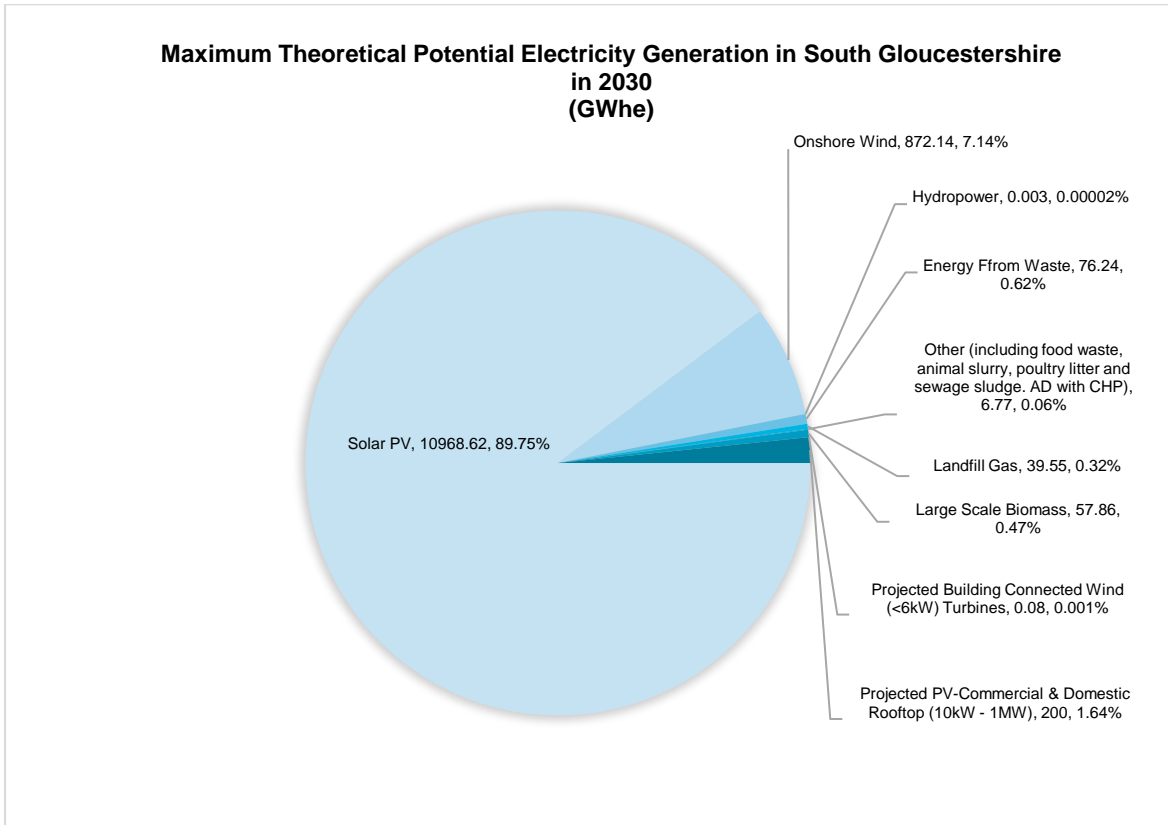

**Figure 15: Maximum Theoretical Potential Electricity Generation in South Gloucestershire in 2030**

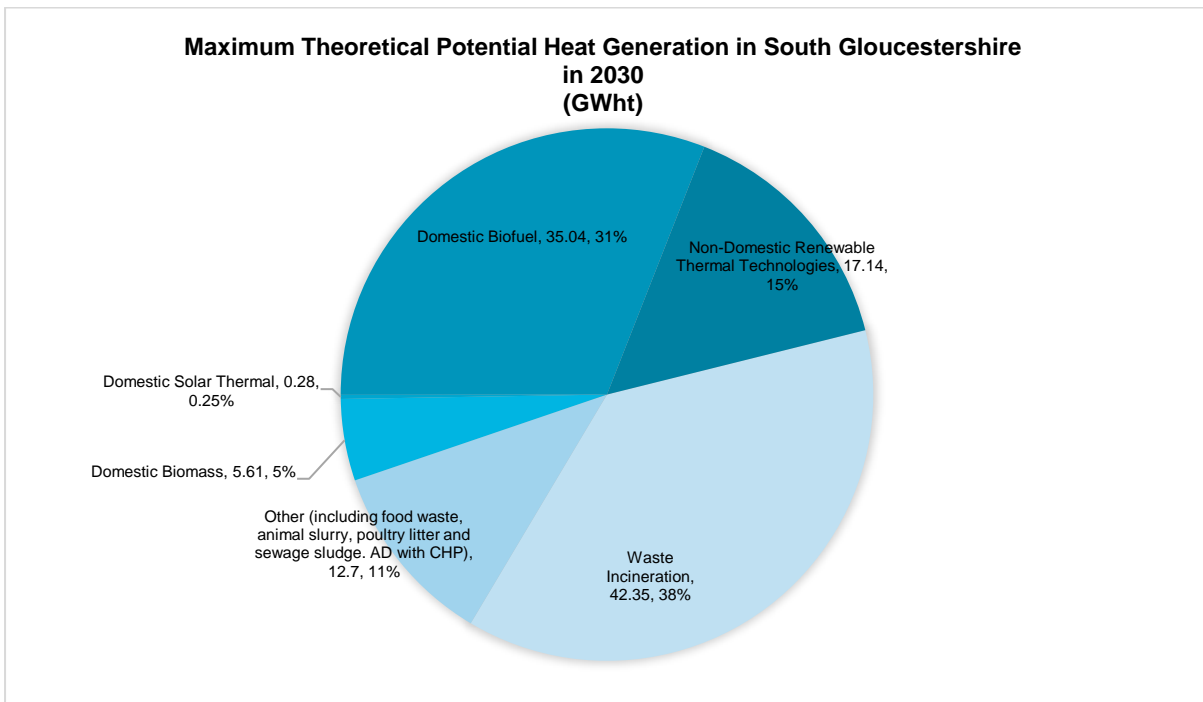

**Figure 16: Maximum Theoretical Potential Heat Generation in South Gloucestershire in 2030, Excluding Electric Heating**

The maximum theoretical potential renewable electricity generation in South Gloucestershire in 2030 is circa 12,221.3GWh, meaning there will be enough potential resource to meet the equivalent of the 2,977 GWh projected electricity demand in 2030.

The maximum theoretical potential from renewable heating technologies, however, is projected to be 113.12GWh in 2030. Therefore, it is concluded that there will only be enough resource to partially meet the equivalent of the projected 258GWh heat consumption by fuels other than electricity.

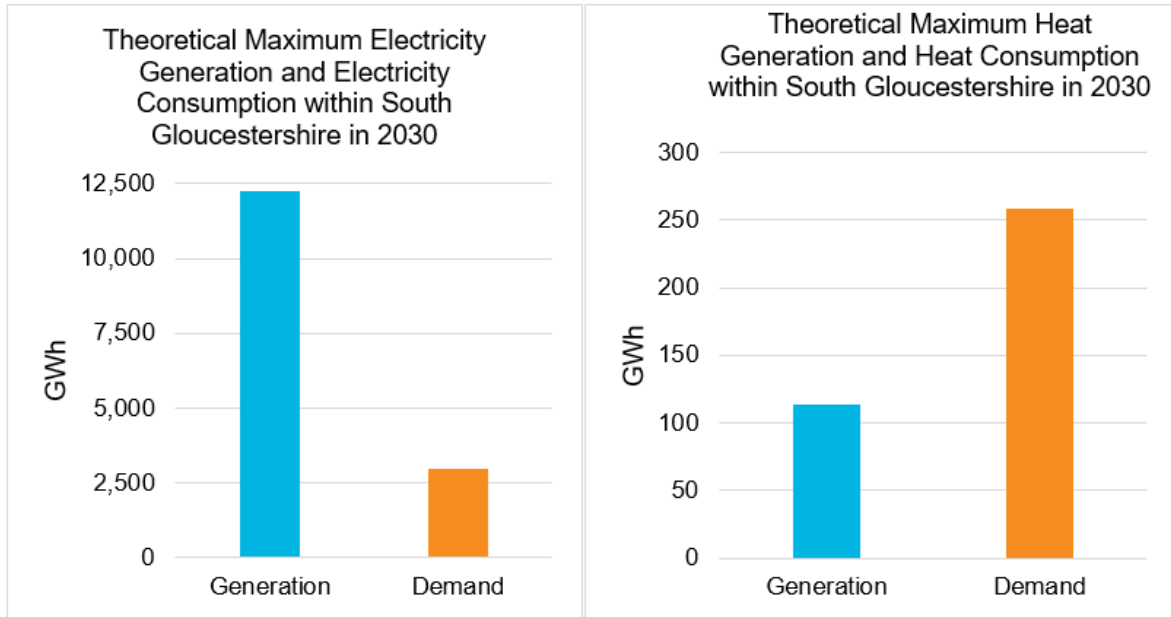

**Figure 17: Theoretical Maximum Electricity and Heat Generation and Consumption within South Gloucestershire in 2030**

### Scenarios for a Carbon Neutral South Gloucestershire in 2030

When considering a carbon neutral South Gloucestershire, it should be noted that all carbon neutral scenarios set out in this RERAS assume that buildings in South Gloucestershire are predominantly heated using heat pumps and that most of the vehicles on the road are electrically driven. That said, there remain different scenarios for renewable energy generation that can be considered. To provide an illustration of the challenge, we have produced the following three scenarios, but it is recommended that the Council aims to maximise the potential for the generation and supply of renewable and low and zero carbon electricity and heat in line with the NPPF.

### **1. Meet the DFES defined efficiency and renewable energy contribution only**

In this scenario, it is assumed that the Consumer Transformation 2050 projections (see Appendix N) set out in the DFES for South Gloucestershire are met in 2030. The energy generation produced by renewables is equivalent to South Gloucestershire's share of grid renewable electricity in 2050 to meet zero carbon. This scenario results in South Gloucestershire greening its share of the grid electricity by 2030. Once other areas 'catch-up' in 2050 as per DFES, South Gloucestershire electricity consumption will become net zero. This scenario includes the assumptions and projections set out in the DFES Consumer Transformation scenario, including the number of heat pumps installed and changes to the heating systems, energy efficiency upgrades in buildings, installation of building integrated and standalone renewables (e.g. solar PV and wind farms) and the transformation of the transport systems (e.g. electric vehicles uptake). This scenario and the following two scenarios are likely to require policy interventions at the local and national levels.

This scenario means that South Gloucestershire would only 'green' the proportion of the grid identified by the DFES.

### **2. Meet the equivalent of 33% of the demand in South Gloucestershire by 2030 and set out a pathway and targets to ensure the equivalent of 100% of the demand is met by 2050.**

This scenario acts as a steppingstone between scenarios 1 and 3 and assumes that 33% of the electricity demand in South Gloucestershire in 2030 will be met by installing additional wind and solar developments in some of the Search Areas identified in this study. As there are certain assumptions outlined in the DFES (such as uptake of heat pumps and electric vehicles) that have been condensed to 2030 in this study, this option provides insurance in case these are not met as a higher proportion of the demand will be met by local renewables in comparison to the scenario one projection. This scenario also includes the assumptions set out in the DFES Consumer Transformation scenario, including the number of heat pumps installed and changes to the heating systems, energy efficiency upgrades in buildings, installation of building integrated renewables and the transformation of the transport systems (e.g. electric vehicles uptake).

The renewable energy generation can then be assessed every 10 years, and the aim increased to ensure the equivalent of 66% of South Gloucestershire's demand can be met by 2040 and 100% by 2050. By 2030, this approach also meets the equivalent of the proportion of the grid identified in the DFES as South Gloucestershire's contribution to UK zero carbon in 2050.

### **3. Meet the 2030 electricity consumption in South Gloucestershire from renewable energy generation located within South Gloucestershire**

This scenario assumes that the 2030 electricity demand in South Gloucestershire will be met by installing additional wind and solar developments in some of the Search Areas identified in this study. The demand could be met through a varying combination of wind development and solar development, promoted through Local Plan policies and strategy. This scenario also includes the assumptions set out in the DFES Consumer Transformation scenario, including the number of heat pumps installed and changes to the heating systems, energy efficiency upgrades in buildings, installation of building integrated renewables and the transformation of the transport systems (e.g. electric vehicles uptake).

## Heat Opportunity and Strategic Site Assessment

A District Heating Network (DHN) is the term given to a distribution system providing multiple individual buildings with heat generated from a single source. The plantroom is generally housed in a building known as an energy centre from which heat can be generated using a renewable or low carbon source such as recovered heat utilising heat pumps.

Traditionally, heat is typically generated at a building level, which means that only small-scale technologies can be used (most commonly gas boilers), limiting the use of other forms of low and zero-carbon heat generation technologies. Unlike the power sector, decarbonising heat at scale will require physical changes to the majority of the heating systems currently installed in buildings and industrial sites<sup>14</sup>. Additionally, sufficient heat demand should exist in close proximity to a heat source to make development viable, making the decarbonisation heating more challenging. A 'Heat Opportunities Map' has been produced providing the locations of heat demand clusters and potential heat sources in the South Gloucestershire area.

The National Planning Policy Framework (NPPF) requires planning authorities to identify a range of suitable housing and employment sites within their area to meet the scale and type of development likely to be needed. The heat opportunities mapping prepared in this study can assist South Gloucestershire Council in sieving potential development sites, as well as developing policies to facilitate increased use of renewable and low carbon energy sources.

Figure 18 shows the results of heat mapping assessment in South Gloucestershire. The size of the circles on the maps indicates the relative size of the heat demand of a building and allows for easily identifiable comparisons to be made between different heat demands. This methodology can also provide a high-level indication of the viability of connecting a heat load. If there are large gaps between circles, it suggests that connecting loads may not be viable. Conversely, if circles overlap, connecting them may be more viable. As shown in Figure 18 below, there are clusters formed in the more residential areas, which could be further investigated. In addition to this, four of these larger clusters have been circled in blue in Figure 18.

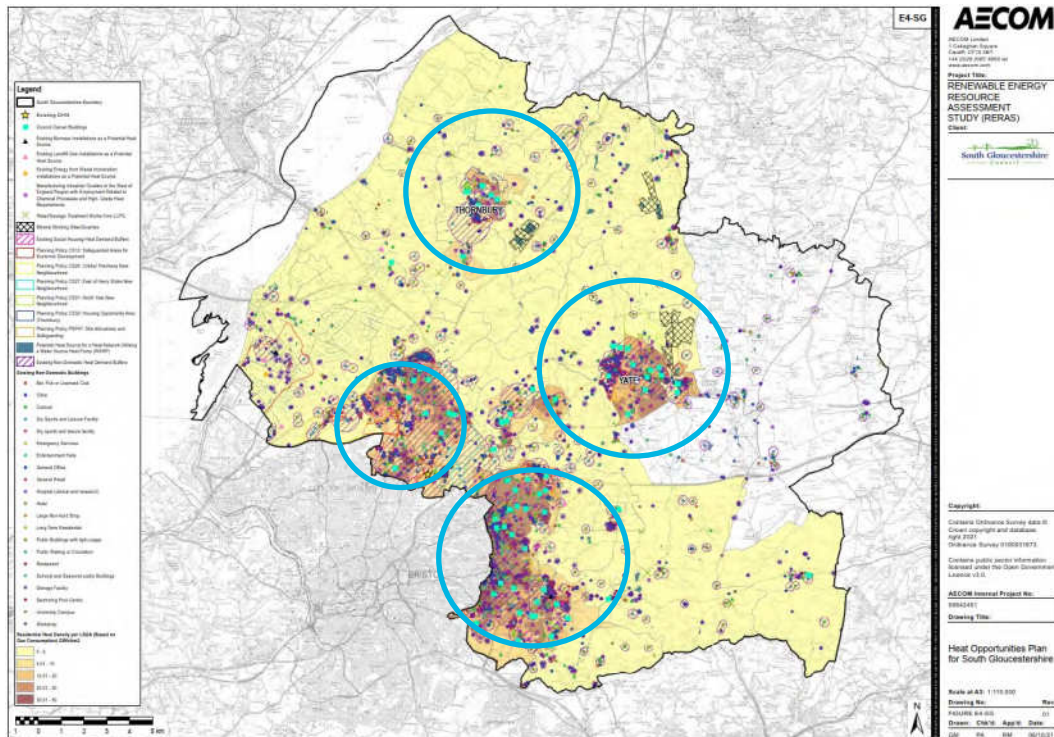

Figure 18: E4-SG: Heat Opportunities for South Gloucestershire Map

<sup>14</sup> [https://assets.publishing.service.gov.uk/government/uploads/system/uploads/attachment\\_data/file/766109/decarbonising-heating.pdf](https://assets.publishing.service.gov.uk/government/uploads/system/uploads/attachment_data/file/766109/decarbonising-heating.pdf)

## Planning Policy Approaches

This RERAS provides the evidence to inform South Gloucestershire Council's new Local Plan policies for renewable energy and associated infrastructure and contains recommendations regarding policy approaches with regard to:

- Net zero carbon scenarios;
- Search Areas for wind farms and solar PV farms;
- Increased energy storage;
- Encouraging the development of and connection to heat networks; and
- Development of other renewable energy resources e.g. biomass, etc.

Based on the evidence gathered as part of the RERAS study, the key policy recommendations are as follows:

For net zero carbon scenarios:

- **SC-PR-1:** It is recommended the three NZC calculations are presented as scenarios, for information only; and
- **SC-PR-2:** It is recommended that the Council aims to maximise the potential for the generation and supply of renewable and low and zero carbon electricity and heat.

For wind farms:

- **WF-PR-1:** It is recommended that the Search Areas (SAs) identified through the RERAS are further refined through the Local Plan process, taking account of other considerations and constraints;
- **WF-PR-2-:** It is recommended that proposals for wind turbines of the appropriate number and size (to make the most efficient use of the resource/ land) benefit from a presumption in favour of wind development when located within the areas identified for that use through the Local Plan;
- **WF-PR-3:** It is recommended that proposals for wind turbines >2.5MW within the areas identified through the Local Plan will benefit from a presumption in favour of wind development, subject to compliance with the primary constraints listed in Section 4.2.1 (e.g. noise, topple distances) and consideration of other site specific issues and constraints;
- **WF-PR-4:** It is recommended that proposals for wind turbines outside of areas identified as suitable for wind development through the Local Plan should be considered positively, providing it can demonstrate that proposals are compliant with relevant policy and site-specific issues and constraints can be mitigated to the satisfaction of the Council;
- **WF-PR-5:** It is recommended that the SAs identified through the RERAS for 1MW and 2.5MW turbines are further refined and safeguarded through the Local Plan process;
- **WF-PR-6:** It is recommended that policy measures (e.g. safeguarding) are put in place to ensure that the areas identified for wind development through the Local Plan are not sterilised by non-wind development;
- **WF-PR-7:** It is recommended that proposals for wind development within areas identified through the Local Plan for 1 and 2.5MW turbines maximise the potential resource. Where this is not the case, applicants should provide evidence as to why this is not feasible or viable;
- **WF-PR-8:** It is recommended that proposals for re-powering of wind farms at end-of-life to an equal or increased capacity will, subject to compliance with the primary constraints listed in Section 4.2.1 (e.g. noise, topple distances), site specific constraints, and other policy considerations should be looked upon favourably; and
- **WF-PR-9:** It is recommended that proposals for wind turbines at the former Oldbury Power Station site will, subject to compliance with noise, topple-distance, site-specific constraints and other policy considerations should be looked upon favourably.

For solar PV farms:

- **SF-PR-1:** It is recommended that the SAs identified through the RERAS are further refined through the Local Plan process, taking account of other considerations and constraints. As part of this a strategy approach which takes account of clustering and the potential need to manage cumulative impact should be considered;
- **SF-PR-2:** It is recommended that proposals for solar PV farms within the areas identified for that use through the Local Plan benefit from a presumption in favour of solar development;
- **SF-PR-3:** It is recommended that proposals for solar development outside of areas identified as suitable for that use through the Local Plan should be considered positively, providing it can demonstrate that proposals are compliant with relevant policy and site-specific issues and constraints can be mitigated to the satisfaction of the Council; and
- **SF-PR-4:** It is recommended that proposals for re-powering of solar PV farms at end-of-life to an equal or increased capacity, subject to compliance with primary constraints, site specific constraints, and other policy considerations should be looked upon favourably.

For energy storage:

- **ES-PR-1:** It is recommended that policy encourages applicants promoting schemes for renewable electricity generation of >1MW, regardless of technology, to consider including storage as part of their proposal. This could include some form of energy storage (green hydrogen production, seasonal or battery storage), private wire supply or evidence as to why this is not feasible or viable;
- **ES-PR-2:** It is recommended that applications for renewable electricity generation of >1MW, located within 1km of an industrial cluster identified as having potential for hydrogen production, consider utilising outputs (via private wire) for such purposes. It is suggested that, prior to implementing this type of policy, the Council may wish to undertake further analysis of existing sites that may employ hydrogen and discuss with existing stakeholders;
- **ES-PR-3:** Building on ES-PR-2, it is recommended that applications for new industrial development that may have a use for green hydrogen should be guided towards locations near/in 'hydrogen clusters' wherever practical; and
- **ES-PR-4:** It is recommended that applications for renewable electricity generation, or development that is energy intensive and likely to have a surplus of heat, within 1km of a site with potential for seasonal energy storage (e.g. abandoned mine workings) should consider utilising such a facility.

For district heating networks:

- **DH-PR-1:** It is recommended that development proposals for dwellings, employment or depots for hosting transport fleets located within 0.5km of an existing renewable heat resources or renewable electricity generating installations should consider utilising such resources for heating, hot water and/or process use transport fuel;
- **DH-PR-2:** It is recommended that proposals for development that will host heat intensive activities and are likely to generate excess heat (or power) should consider:
  - a. Potential to be located within 0.5km of a heat demand cluster identified in the Heat Opportunities Map or other identified heat use;
  - b. Enabling heat (power) off-take for supply for other / nearby uses and provide evidence of discussions with potential off-takers for the heat (or power).
- **DH-PR-3:** It is recommended that development proposals within 0.5km of an existing district heat network fed from a renewable (non-fossil fuel) source will be expected to connect where feasible and viable; and
- **DH-PR-4:** It is recommended that areas identified through the Local Plan for wind farms and solar PV farms are within 0.5km of an identified heat cluster, consideration is given to safeguarding these sites in order to provide electricity for powering heat pumps as part of a private wire / district heat network.

For biomass:

- **BM-PR-1:** It is recommended that proposals utilising biomass are looked upon favourably where:
  - a. a whole life carbon benefit can be evidenced; and
  - b. the development should be located away from urban areas (and preferably in areas off the gas grid).
- **BM-PR-2:** It is recommended that proposals for stand-alone electricity generation plant utilising biomass should be required to utilise a BECCS system, and a whole life carbon benefit can be evidenced.

These policy recommendations are explained in more detail in Section 17 of the main RERAS report.

# Renewable Energy Resource Assessment Study (RERAS) Main Report

## 1. Introduction

The UK Government is required to contribute to achieving international targets for greenhouse gas emission reductions. The Climate Change Act 2008 provides the statutory framework for reducing greenhouse gas emissions in the UK<sup>15</sup>. At the core of the Act is a requirement for the UK to reduce net UK greenhouse gas emissions by 100% (net zero emissions) by 2050. The Act established a system of five-yearly carbon budgets to serve as stepping-stones on the way.

England originally had a carbon budget of 80% by 2050 against a 1990 baseline in legislation. However, to reach the net zero emissions target, in 2019, this figure was replaced with a target of 100% against a 1990 baseline.

As part of UN negotiations, more than 190 countries, including the UK committed to the Paris Agreement to tackle climate change. The Agreement entered into force on 4<sup>th</sup> November 2016 and set out a global framework to limit the global average temperature increase due to global warming to well below 2°C and pursue efforts for 1.5°C.

The UK Renewable Energy Roadmap sets the path for the delivery of these targets. The first six-carbon budgets, leading to 2037, have been set in law. The first two budgets have been met (2008-12, 25% and 2013-2017, 31%), and the third is very likely to be met (2018-22, 37%). The remaining budget targets are as follows:

- Meeting the fourth carbon budget (2023-2027) will require that emissions be reduced by 50% on 1990 levels in 2025;
- Meeting the fifth carbon budget (2028-2032) will require that emissions be reduced by 57% on 1990 levels in 2030; and
- Meeting the sixth carbon budget (2033-2037) will require that emissions reduce by 78% on 1990 levels in 2035.

The UK Government is committed to playing its part by delivering an energy programme that contributes to reducing carbon emissions as part of its approach to mitigating anthropogenic climate change whilst enhancing the economic, social and environmental wellbeing of our own and future generations. This is outlined in the Ten Point Plan for a Green Industrial Revolution<sup>16</sup> and the Energy White Paper<sup>17</sup>.

### 1.1 South Gloucestershire

South Gloucestershire is a richly varied district in the South West of England. The area comprises multiple suburban areas alongside large rural areas, including a green belt. South Gloucestershire covers an area of 536.4km<sup>2</sup> and has a population of approximately 285,093 people, based on 2019 figures<sup>18</sup>.

On 17<sup>th</sup> July 2019, South Gloucestershire Council declared a climate emergency. A Climate Emergency Strategy<sup>19</sup> was developed in which the council pledges:

- For South Gloucestershire to become carbon neutral by 2030;
- To maximise the generation of renewable energy from installations located within South Gloucestershire;

<sup>15</sup> *Climate Change Act 2008*, c.27. Available at: <https://www.legislation.gov.uk/ukpga/2008/27/introduction> (Accessed: 24 September 2020).

<sup>16</sup> [https://assets.publishing.service.gov.uk/government/uploads/system/uploads/attachment\\_data/file/936567/10\\_POINT\\_PLAN\\_BOOKLET.pdf](https://assets.publishing.service.gov.uk/government/uploads/system/uploads/attachment_data/file/936567/10_POINT_PLAN_BOOKLET.pdf)

<sup>17</sup> [https://assets.publishing.service.gov.uk/government/uploads/system/uploads/attachment\\_data/file/945899/201216\\_BEIS\\_EW\\_P\\_Command\\_Paper\\_Accessible.pdf](https://assets.publishing.service.gov.uk/government/uploads/system/uploads/attachment_data/file/945899/201216_BEIS_EW_P_Command_Paper_Accessible.pdf)

<sup>18</sup> <https://www.southglos.gov.uk/council-and-democracy/census/population-and-demographics/>

<sup>19</sup> <https://www.southglos.gov.uk/documents/2213-Climate-Emergency-Strategy-Digital-v4.pdf>



- To ensure South Gloucestershire is prepared for the local impacts of a changing climate;
- To ensure that nature in our local area is more protected, connected and healthy and that biodiversity is increased; and
- To plant trees across South Gloucestershire by 2030 to double tree canopy cover.

To aid these aims, a Climate Emergency Action Plan will be set out every year until 2030.

South Gloucestershire's Development Plan consists of the Core Strategy<sup>20</sup>, Policies Sites and Places Plan<sup>21</sup> and the Joint Waste Core Strategy<sup>22</sup>. In 2013, South Gloucestershire adopted the Core Strategy. The document details the policies in place to develop and optimise land up to 2027 to help secure a sustainable future. The Core Strategy distils social, economic, and environmental challenges into six key drivers of change:

- Responding to Climate Change and High-Quality Design;
- Managing Future Development;
- Tackling Congestion and Improving Accessibility;
- Managing the Environment and Heritage;
- Maintaining Economic Prosperity; and
- Providing Housing and Community Infrastructure

The purpose of the Policies, Sites and Places (PSP) Plan, adopted in 2017, is to support the delivery of the Core Strategy. It comprises of a suite of development management policies and details about site allocations.

The Council is currently at the early stages of developing a new Local Plan. The Local Plan 2020 will include a new strategy and policies to guide and manage growth and change in South Gloucestershire over the next 15 years.

## 1.2 Purpose of this Assessment

South Gloucestershire has several key roles to play that can facilitate the use and generation of renewable and low and zero-carbon energy. These include:

- Preparing planning policies and allocating land or identifying areas of search to inform preparation of the new Local Plan (LP);
- Development management – taking decisions on planning applications submitted to the Council for development;
- Corporate – taking action at a council-wide level to achieve a low carbon economy; and
- Leadership – taking forward wider community action and communicating the need to increase the uptake of renewable energy.

This Renewable Energy Resource Assessment Study (RERAS) constitutes an evidence base informing the LP. This enables decisions to be taken based on policies that support and facilitate the deployment of renewable and low and zero-carbon energy systems. The RERAS consists of a bottom-up assessment of the potential for different renewable and low and zero carbon energy generation scales in different locations.

In terms of development management, the RERAS will be useful in three ways.

- **Firstly**, when assessing applications for new development sites, it can aid officers in discussions with developers around opportunities for district heating and making use of waste heat;

<sup>20</sup> <https://beta.southglos.gov.uk/wp-content/uploads/South-Gloucestershire-Core-Strategy-2006-2027.pdf>

<sup>21</sup> <https://www.southglos.gov.uk/documents/PSP-Plan-Interim-Web-Version.pdf>

<sup>22</sup> <https://beta.southglos.gov.uk/wp-content/uploads/Joint-Waste-Core-Strategy.pdf>

- **Secondly**, when assessing applications for larger-scale new generation schemes, it can enable officers to identify whether there is the potential for those schemes to supply heat to new or existing development; and
- **Thirdly**, in the case of wind and solar PV farm developments and other technologies, it can assist officers in understanding why a developer has chosen a particular location to develop a scheme.

### 1.3 Method Employed in this Renewable Energy Resource Assessment

This RERAS is compiled in alignment with government policy as set out in the Renewable Energy and Low-Carbon Energy Capacity Methodology for the English Regions<sup>23</sup>. Using educated assumptions about the technologies likely to be employed for converting resource, energy generation figures have been produced for use in considering planning policy with a view to meeting the council's 2030 aims. Also, where appropriate, methods have been used to meet the National Planning Policy Framework requirements and to better reflect local data/circumstances.

Maps have been produced to enable spatial identification and provide a visual representation of the potential renewable energy opportunities. These maps were produced using Geographic Information Systems (GIS), where overlaying multiple datasets has enabled a reveal of opportunity by removing layers of primary constraints. The primary constraints data was overlaid in stages and relate to resource, technology, safety, protection of heritage and the environment, as well as other categories. The maps referred to in this RERAS can be located in the document 'South Gloucestershire RERAS – Maps'.

### 1.4 Why this Renewable Energy Resource Assessment Study is Important

This RERAS will inform action to support the deployment and delivery of renewable and low and zero-carbon energy installations on the ground. This is expected to assist in meeting the two key challenges for UK energy policy, namely:

- Mitigating anthropogenic climate change by reducing carbon dioxide emissions, and;
- Improving energy security.

At a council strategic level, this RERAS provides an evidence base for the following policy<sup>24</sup> objectives:

- Identification and promotion of potential sites for renewable energy generation (not necessarily linked to new buildings);
- Development of area-wide renewable energy contributions (e.g. installed megawatt of heat and electricity generation) as a stimulus for concerted local action;
- Informing the selection of land for development (allocation of sites), by identifying those sites with the greatest potential for sustainable energy and carbon reduction or sites that potentially could preclude renewable energy developments (e.g. by sterilising good wind power sites);
- Identification of opportunities for delivering strategic energy options that could link to an offset fund (i.e. some Councils, where land values may be less, view this as an opportunity to make sites more attractive to developers by making them "low and/or zero-carbon enabled", rather than seeking to increase development burden by setting sustainability standards above future Building Regulations.); and
- To enable South Gloucestershire Council's exploration of requiring developers to connect to an existing or proposed district heating network (e.g. how much could they charge, how close would a development need to be and so on).

<sup>23</sup>[https://assets.publishing.service.gov.uk/government/uploads/system/uploads/attachment\\_data/file/226175/renewable\\_and\\_low\\_carbon\\_energy\\_capacity\\_methodology\\_jan2010.pdf](https://assets.publishing.service.gov.uk/government/uploads/system/uploads/attachment_data/file/226175/renewable_and_low_carbon_energy_capacity_methodology_jan2010.pdf)

<sup>24</sup> Meant in the broad sense, i.e. not just planning policy

This RERAS delineates South Gloucestershire's evidence base to inform the Council's approach to securing renewable energy developments. Suggestions for policy amendments have been provided for South Gloucestershire to consider.

This RERAS presents information that is potentially useful to developers and wider stakeholders alike in facilitating partnerships and taking forward delivery of the opportunities identified for South Gloucestershire.

#### 1.4.1 Wider Corporate Role

The NPPF requires all local planning authorities, including South Gloucestershire to take a proactive approach to mitigate and adapt to climate change. This RERAS enables South Gloucestershire to identify specific opportunities to facilitate renewable and low and zero-carbon energy generation.

The opportunities identified can form the basis of more detailed implementation plans, feasibility studies and practical action to contribute towards a broader range of objectives. For instance, the opportunities may contribute to delivering local economic benefits either in terms of locally grown fuel supplies or by enabling a proportion of expenditure on energy to be retained within the local economy, from local generation, rather than utilising external energy companies.

### 1.5 Scope of this Renewable Energy Assessment

#### 1.5.1 Planning

The RERAS focuses on planning policy though there are associated implications for development management. This assessment has been developed primarily for South Gloucestershire Council as an evidence base to inform renewable and low and zero-carbon energy contributions and policies in the Local Plan.

This RERAS, and the aims and policies that it informs, will feed in to procedures for use by development management officers to assess planning applications for stand-alone renewable energy generating systems.

#### 1.6 Technology

This assessment is not an exhaustive guide to the different renewable and low and zero-carbon energy technologies available. The National Policy Statements<sup>25</sup> provide generic and technology-specific advice relevant to siting particular renewable and low and zero-carbon technologies that should be the first point of reference. Other technologies are listed by the Department for Business Energy and Industrial Strategy (BEIS - formerly the Department for Energy and Climate Change<sup>26</sup>) and the Energy Saving Trust<sup>27</sup>.

##### 1.6.1 Energy Hierarchy

The RERAS focuses on renewable and low and zero-carbon energy generation and the opportunities for promoting this through the LP, rather than on improving energy efficiency in new or existing buildings.

Where energy efficiency assumptions were required within the study, for instance, in calculating the future renewable energy generation needed to meet future carbon reduction targets, these have been made in line with the Western Power Distribution's (WPD) Distribution Future Energy Scenarios (DFES)<sup>28</sup> Consumer Transformation scenario. These assumptions include the continual improvement

<sup>25</sup> <https://www.gov.uk/guidance/consents-and-planning-applications-for-national-energy-infrastructure-projects>

<sup>26</sup> DECC <http://www.planningrenewables.org.uk/page/index.cfm>

<sup>27</sup> Energy Saving Trust a: <https://energysavingtrust.org.uk/home-energy-efficiency>

<sup>28</sup> WPD DFES 2020: <https://www.regen.co.uk/wp-content/uploads/WPD-DFES-2020-technology-summary-report-South-West.pdf>

of domestic energy efficiency. Readers are referred to other sources of information on energy efficiency in buildings<sup>29</sup>.

### 1.6.2 Transport

The RERAS does not include an assessment of the potential for renewable or low carbon fuels for transport, except for a calculation of the current and future demand from electric vehicles, which is kept in alignment with the WPD DFES.

### 1.6.3 Stand-Alone Electricity Generating Assets

The RERAS is concerned with identifying the potential for additional renewable electricity generation opportunities. Search Areas (SAs) are identified for larger wind and solar photovoltaic (PV) farms that should be investigated further and refined through the Local Plan process. This approach does not necessarily preclude proposals for smaller-scale wind and solar farms from coming forward outside of the areas identified through the Local Plan.

### 1.6.4 Soundness

While this RERAS is prepared in line with government policy as set out in the NPPF and supporting Planning Practice Guidance, there is no definitive advice for undertaking such studies. It is the responsibility of the Council to prepare 'sound' evidence to support the policies and approaches it takes through its Local Plan. The Council has appointed AECOM to assist in this evidence gathering, and the methodology employed in this study is based on the methodology published by DECC<sup>30</sup> and AECOM's experience of preparing similar studies for other authorities. Assumptions and data used in carrying out this RERAS have been sought from established sources, and these are either referenced as footnotes to the text or appropriately appended. Where there were no established sources, they have been derived based on available evidence and through dialogue with the Council.

In the future, guidance, assumptions and data sources may change, particularly as technology and the policy and regulatory framework evolves.

## 1.7 Defining Renewable Energy and Low and Zero Carbon Energy

### 1.7.1 Renewable Energy

Renewable energy can be described as:

---

*"That which makes use of energy flows which are replenished at the same rate as they are used<sup>31</sup>"*

---

The National Planning Policy Framework (NPPF<sup>32</sup>) defines renewable energy as follows:

---

*"Renewable energy covers those energy flows that occur naturally and repeatedly in the environment – from the wind, the fall of water, the movement of the oceans, from the sun and also from biomass and deep geothermal heat. Low carbon technologies are those that can help reduce emissions (compared to conventional use of fossil fuels)"*

---

<sup>29</sup> E.g. from the Energy Saving Trust, as per the web-link given above.

<sup>30</sup> [https://assets.publishing.service.gov.uk/government/uploads/system/uploads/attachment\\_data/file/226175/renewable\\_and\\_low\\_carbon\\_energy\\_capacity\\_methodology\\_jan2010.pdf](https://assets.publishing.service.gov.uk/government/uploads/system/uploads/attachment_data/file/226175/renewable_and_low_carbon_energy_capacity_methodology_jan2010.pdf)

<sup>31</sup> Sorensen, B. (1999) Renewable Energy (2nd Edition), Academic Press, ISBN 0126561524

<sup>32</sup> National Planning Policy Framework, Ministry of Housing, Communities & Local Government, 2021:

[https://assets.publishing.service.gov.uk/government/uploads/system/uploads/attachment\\_data/file/1005759/NPPF\\_July\\_2021.pdf](https://assets.publishing.service.gov.uk/government/uploads/system/uploads/attachment_data/file/1005759/NPPF_July_2021.pdf)

Another important characteristic of renewable energy, which will be explained in more detail below, is that, unlike fossil fuels, it produces little or no net carbon dioxide<sup>33</sup> (CO<sub>2</sub>), which is one of the main greenhouse gas emissions.

Most forms of renewable energy stem directly or indirectly from the sun. The direct ones include solar water heating and PV panels (electricity), and ground source heat pumps<sup>34</sup> that make use of solar energy stored in the ground. The primary indirect forms are:

- Wind power, as wind is caused by differential warming of the Earth's surface by the sun;
- Hydropower, as rainfall is driven by the sun causing evaporation from the oceans;
- Biomass energy (from burning organic matter), as all plants photosynthesise sunlight in order to fix carbon and grow.<sup>35</sup>

The other two forms of renewable energy are:

- Tidal power, which relies on the gravitational pull of both the sun and the moon;
- Geothermal energy, which taps into the heat generated in the Earth's core.

Of all these resources, perhaps the most complex and versatile is biomass energy because it can take many forms. Biomass energy<sup>36</sup> can include:

- combustion of forestry residues;
- anaerobic digestion (AD) of higher moisture content wastes such as from animal manures and food wastes;
- combustion of straw and other agricultural residues and products;
- methane produced from the AD of biodegradable matter in landfill sites (i.e. landfill gas), and;
- energy generated from the biodegradable fraction of waste going into an Energy from Waste (EfW) plant.

In addition to the above, nuclear fusion can also be considered as clean energy since nuclear fusion reactors produce no high activity, long-lived nuclear waste. However, this technology is not yet commercially available; further details regarding nuclear fusion is provided in the next section.

Moreover, hydrogen is also considered in this RERAS but included under a separate subheading. This is because hydrogen is an energy carrier, and it can be produced using renewable electricity, which is called green hydrogen.

---

<sup>33</sup>Burning biomass releases carbon dioxide (CO<sub>2</sub>), a greenhouse gas. However, the plants that are the source of biomass for energy capture almost the same amount of CO<sub>2</sub> through photosynthesis while growing as is released when biomass is burned, which can make biomass a carbon-neutral energy source. 'Net' CO<sub>2</sub> is the difference between the amount of greenhouse gasses produced and the amount removed from the atmosphere during the process

<sup>34</sup> Strictly speaking, these technologies are only partially renewable, as they also make use of, most commonly, grid electricity to power a compressor. However, if they have a good efficiency, they can provide a form of heating, in the UK, that produces less carbon per unit of output than using a gas condensing boiler.

<sup>35</sup> If replanting occurs, the combustion of biomass fuel is acknowledged as carbon neutral, because although the combustion process releases CO<sub>2</sub>, equal amounts of CO<sub>2</sub> were taken out of the atmosphere when the biomass was growing

<sup>36</sup> Biomass is generally regarded as non-fossil fuel when at least 98% of the energy content is derived from plant or animal matter, or substances derived thereof.

## 1.8 Renewable Technologies Addressed in this Renewable Energy Resource Assessment Study

This RERAS covers the following renewable energy technologies (considering both electricity and heat)<sup>37</sup>:

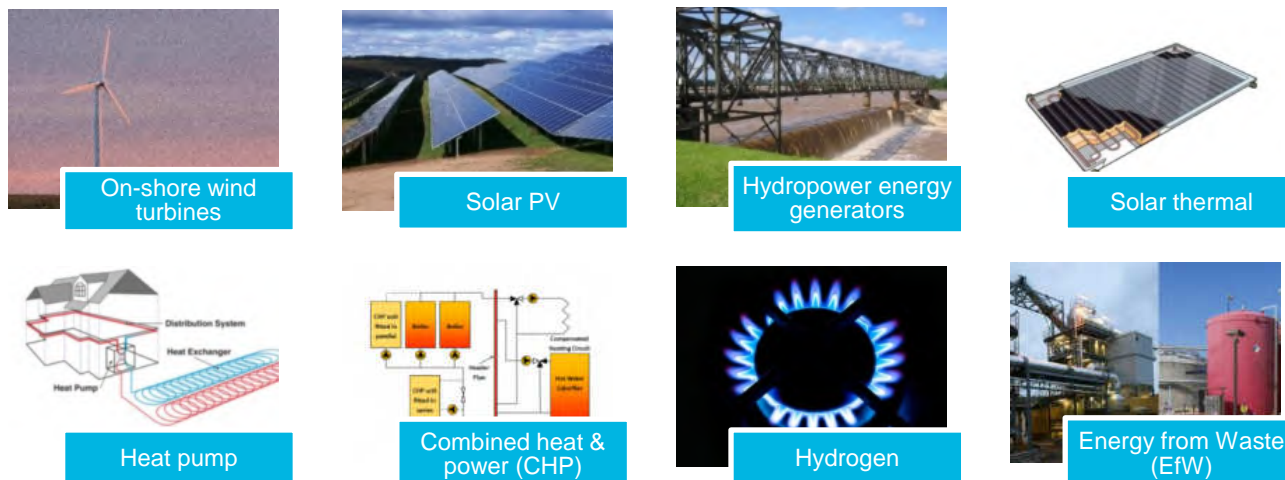

Sections 1.8.1 to 1.8.12 cover these technologies as well as nuclear fusion in greater detail.

Further details regarding marine renewables are provided in Section 1.8.7; however, they are excluded from this assessment as decisions about such development are outside the jurisdiction of the Council<sup>38</sup>.

<sup>37</sup> On-shore wind turbines, Solar PV, Hydropower energy generation and Energy from Waste photos from:

<https://aecom.assetbank-server.com/assetbank-aecom/action/viewHome>

Solar thermal photo:

[https://assets.publishing.service.gov.uk/government/uploads/system/uploads/attachment\\_data/file/879765/Solar\\_Thermal\\_TIL\\_-\\_April\\_2020.pdf](https://assets.publishing.service.gov.uk/government/uploads/system/uploads/attachment_data/file/879765/Solar_Thermal_TIL_-_April_2020.pdf)

Heat pump photo: <https://www.newcastle.gov.uk/services/environment-and-waste/energy-services/electrification-heat/electrification-heat-heat-pump>

Combined heat & power photo:

[https://assets.publishing.service.gov.uk/government/uploads/system/uploads/attachment\\_data/file/961492/Part\\_2\\_CHP\\_Technologies\\_BEIS\\_v03.pdf](https://assets.publishing.service.gov.uk/government/uploads/system/uploads/attachment_data/file/961492/Part_2_CHP_Technologies_BEIS_v03.pdf)

<sup>38</sup> Decisions on marine or offshore energy is for the UK Government of Secretary of State

### 1.8.1 On-Shore Wind Turbines



**Figure 19: Earthcott Wind Farm - Alveston**

On-shore wind power is a 'mature technology' that is being used for electricity generation worldwide. Most turbines are currently designed using a horizontal axis three-blade rotor system mounted on a steel mast. The blades drive a generator either directly or via a gearbox (generally for larger machines) to produce electricity. Turbines can produce electricity without carbon dioxide emissions, ranging from watts to megawatt outputs.

There are various wind turbines on the market ranging from smaller turbines that can be attached directly to a building to larger stand-alone turbines. However, the performance of very small-scale wind turbines, i.e. building-connected turbines (<20 kW), are impacted disproportionately by turbulence and lower wind speeds from their positioning within their urban setting.

Small turbines ( $\leq 500\text{kW}$ ) are most commonly deployed as single machines supplying specific buildings or developments and sometimes used in community energy projects. Large scale commercial turbines ( $>2.5\text{MW}$ ) are more often used in groups as part of larger wind farm developments, as shown in Figure 19<sup>39</sup>.

### 1.8.2 Solar Photovoltaic

Solar PV systems use solar cells to generate electricity directly from sunlight. The solar cells are normally packaged together into panels or other modular forms, and the technology is technically well-proven with numerous systems installed around the world, ranging from small domestic systems (circa 3.5 kW) to large PV farms (several MWs), see Figure 20<sup>40</sup>.



**Figure 20: A Rooftop Solar Array**

PV systems convert energy from the sun into direct current (DC) electricity using semi-conductor cells connected and mounted into modules. Modules are connected to an inverter that converts DC into alternating current (AC), enabling integration with the normal grid supply.

PV modules can be placed on a fixed stand/roof or equipped with a tracking system that allows the modules to follow the sun's course. This can potentially increase electricity production compared with modules at a fixed azimuth (a PV array's east to west orientation in degrees) and inclination but can be an expensive addition, usually reserved for larger-scale installations.

PV technology is common in the UK, and new technologies such as solar tiles, which can be integrated into new buildings or refurbishments alongside conventional roofing tiles, are becoming more widely available. If the output of a PV system exceeds the building consumption at any time, the surplus electricity can then be exported to the grid.

<sup>39</sup> South Gloucestershire Council, Earthcott Wind Farm.

<sup>40</sup> AECOM Multi Media Library

### 1.8.3 Hydropower Energy Generators

Hydropower is the energy derived from flowing water. This can be from rivers or built installations, where water flows from a high-level reservoir down through a tunnel and away from a dam<sup>41</sup>. The water drives a turbine connected to an electrical generator, with the energy generated proportional to the volume of water and vertical drop or head. It should be noted that the only generation of electricity from inland (non-coastal) watercourses are considered in this section.

The technology is well-established, and most large-scale resources are exploited in the UK. However, the potential exists for small scale 'run of river' schemes (where no water storage is required). These are relatively small systems, with some flexibility in siting along a length of river or stream.

---

*"Run-of-river schemes use the natural flow of a river, where a weir can enhance the continuity of the flow. Both storage and run-of-river schemes can be diversion schemes, where water is channelled from a river, lake or dammed reservoir to a remote powerhouse containing the turbine and generator."<sup>41</sup>*

---

Large hydropower generation schemes are usually connected to the electricity grid due to the larger loads and the absence of a demand in the immediate vicinity. However, small micro schemes could be linked to buildings and/or processes (signals/lights, etc.).

Figure 21 shows a run-of-river hydropower scheme.

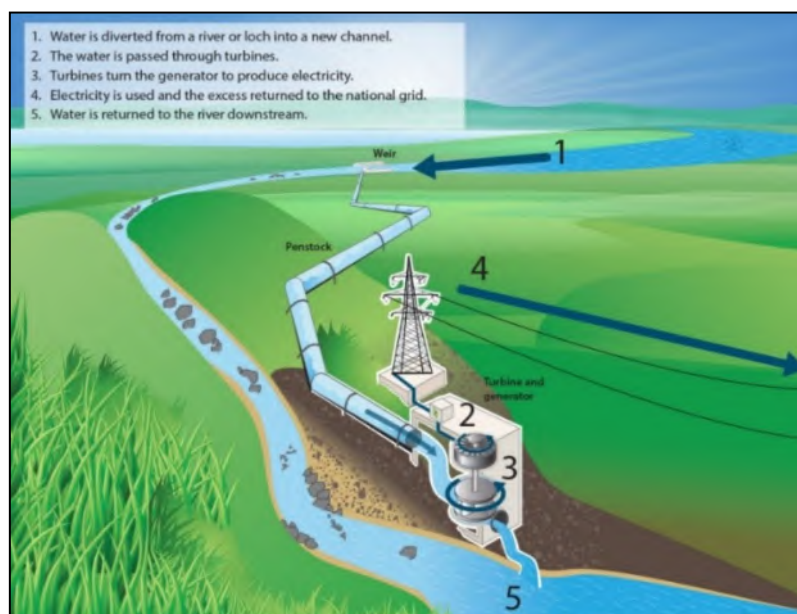

Figure 21: A Run-of-River Hydropower Scheme<sup>42</sup>

### 1.8.4 Solar Thermal

Solar thermal systems use solar collectors, usually placed on the roof of a building, to preheat water for use in hot water applications in the building. A conventional boiler or immersion heater can increase the temperature of the water or provide hot water when solar energy is unavailable. Figure 22 below shows a summary of such a system.

<sup>41</sup> <https://www.gov.uk/guidance/harnessing-hydroelectric-power>

<sup>42</sup> [https://www.sepa.org.uk/media/148411/run\\_of\\_river\\_hydropower\\_scheme.jpg](https://www.sepa.org.uk/media/148411/run_of_river_hydropower_scheme.jpg)



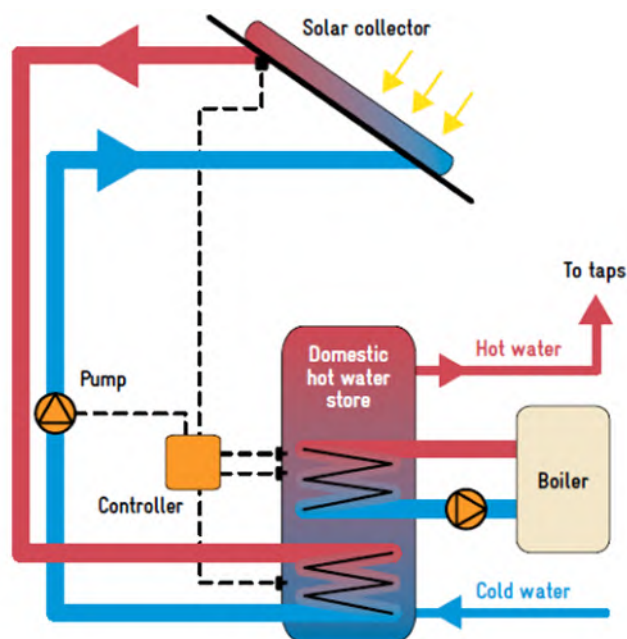

Figure 22: Systematic of a Solar Thermal System<sup>43</sup>

### 1.8.5 Heat Pumps

Heat pump systems absorb the solar heat energy stored in the ground, water bodies, or air into a fluid at low temperature. The fluid is then passed through a compressor to increase its temperature for heating purposes (e.g. space or water heating in buildings)<sup>44</sup>. Larger heat pumps can also be incorporated in district heating schemes.

Although the heat pumps extract renewable heat from the environment, they use electricity as fuel, which may or may not come from renewable sources. However, one of the significant advantages of heat pumps compared to other heat delivery systems is that the heat output is greater (typically 2 to 3 times) than the electricity input, making them an energy-efficient heating method<sup>45</sup>.

### 1.8.6 Combined Heat and Power

A combined heat and power engine (CHP) is a highly efficient process that captures and utilises the heat that is a by-product of the electricity generation process. By generating heat and power simultaneously, CHP can potentially produce less carbon emissions compared to the separate means of conventional generation via individual boilers in buildings coupled with electricity from centralised power stations<sup>46</sup>. The technology is well established, and there is a wealth of options for different fuel types and system designs. However, it should be noted that due to changing carbon factors, fossil-fuelled systems on their own will increasingly struggle to achieve carbon savings over the plant lifecycle.

The economic viability of the system is generally achieved due to the difference in cost between grid electricity and the CHP fuel source, known as the 'spark spread', and the general principle that operating the CHP system for longer usually provides greater benefits because savings are typically achieved for each unit of electricity and useful heat which are generated. There can be a substantial greenhouse gas emission benefit due to the difference in emission factors for delivered energy and

<sup>43</sup> Solar Thermal Systems and Collectors, BEIS; [https://assets.publishing.service.gov.uk/government/uploads/system/uploads/attachment\\_data/file/879765/Solar\\_Thermal\\_TIL\\_-\\_April\\_2020.pdf](https://assets.publishing.service.gov.uk/government/uploads/system/uploads/attachment_data/file/879765/Solar_Thermal_TIL_-_April_2020.pdf)

<sup>44</sup> [https://energysavingtrust.org.uk/advice/air-source-heat-pumps/#:~:text=Air%2Dto%2Dwater%20heat%20pumps,your%20wet%20central%20heating%20system.&text=They%20will%20not%20provide%20you,Heat%20Incentive%20\(RHI\)%20scheme.](https://energysavingtrust.org.uk/advice/air-source-heat-pumps/#:~:text=Air%2Dto%2Dwater%20heat%20pumps,your%20wet%20central%20heating%20system.&text=They%20will%20not%20provide%20you,Heat%20Incentive%20(RHI)%20scheme.)

<sup>45</sup> <https://energysavingtrust.org.uk/advice/air-source-heat-pumps/>

<sup>46</sup> <https://www.gov.uk/guidance/combined-heat-and-power>, DECC, June 2021

the improved energy utilisation. Energy export is also possible, depending on the site energy demand profile.

For the engine to operate safely, the heat it generates must be removed; a CHP system requires a suitable thermal energy demand to operate properly. The correct sizing of a CHP system is critical because an oversized system may not be able to run for long hours if the thermal demand is insufficient, often leading to increased maintenance costs and engine failures.

CHP plants are available in various scales, from micro-CHP domestic applications to large industrial applications and CHP plants serving district heating schemes<sup>47</sup>.

Descriptions of biomass, EfW, AD and landfill gas are provided in this section; however, it should be noted that utilisation of these renewable sources is not limited to CHP technology.

#### 1.8.6.1 Biomass Combined Heat & Power and/or Biomass Boilers

Biomass is a broad term covering all organic material and can be generally defined as material of recent biological origin, derived from plant or animal matter. This could include materials from plants (for example, forestry residues, Miscanthus and short rotation coppice) and animals (for example, poultry litter)<sup>48</sup>. Whilst scientific debate continues on this subject. Biomass is normally considered a carbon-neutral fuel, as the carbon dioxide emitted during burning has been (relatively) recently absorbed from the atmosphere by photosynthesis and no fossil fuel is involved. However, there are carbon emissions associated with the sourcing, processing and transportation of the biomass that should be accounted for.

This section mainly focuses on the type of 'dry' biomass that is more commonly combusted to generate heat or produce electricity.

Biomass heating is an established and proven technology. The technology can be used to provide heat to buildings of all sizes, either through individual boilers or via district heating networks. Biomass can also be incorporated in a fuel electricity plant or CHP plant due to the low carbon emissions associated with its use<sup>49</sup>.

Unlike solar and wind renewable energy sources, biomass fuel is not abundant and free. When comparing costs, wood chips and pellets are becoming progressively more competitive compared to increasing gas prices. However, biomass prices are known to fluctuate due to various market forces.

Building-integrated woodchip-fuelled systems are typically fed automatically by screw-drives from fuel hoppers and incorporate automatic de-ashing. Systems are designed to burn without emitting smoke and must meet strict air quality emission limits to comply with the Clean Air Act <sup>50</sup>.

It should be noted that the current trend is to move away from centralised electricity plants that do not utilise any of the waste heat. Therefore, any new, large plant is likely to be required to have higher thermal efficiency and linked in with some processes to use heat (e.g. steam, waste treatment, etc.).

Some of the potential issues of using biomass are as follows:

- Guarantee that there will be a sustainable and quality fuel source once a biomass plant is built;
- Assessing the conflict of land use and virgin feedstocks;
- The extensive time taken for plant stocks to grow;
- The carbon emissions released in the processing and transportation of the biomass fuels and the need for re-planting; and
- The health concerns relating to the emissions of burning biomass.

<sup>47</sup> <https://gov.wales/sites/default/files/publications/2018-09/generating-your-own-energy-combined-heat-power.pdf>

<sup>48</sup> <https://www.ons.gov.uk/economy/environmentalaccounts/articles/aburningissuebiomassisthebiggestsourceofrenewableenergyconsumedintheuk/2019-08-30#:~:text=Embed%20this%20interactive%20Copy,material%20from%20plants%20or%20animals.>

<sup>49</sup> <https://gov.wales/sites/default/files/publications/2018-10/planning-implications-renewable-energy-development.pdf>

<sup>50</sup> Clean Air Act 1993 - <https://www.legislation.gov.uk/ukpga/1993/11/contents>

### 1.8.6.2 Health Concerns

If strict air quality requirements are not met, there can be concerns about the impact on human health from the resulting emissions. These emissions include particulate matter (PM) and gases such as carbon monoxide (CO), carbon dioxide (CO<sub>2</sub>) and nitrogen oxides (NO<sub>x</sub>).

Small PM, less than 10 micrometres in diameter, can lead to severe health problems, affecting both the heart and the lungs. Biomass burning leads to emissions of PM<sub>10</sub> and PM<sub>2.5</sub>, putting the size of the PM released below the 10-micrometre diameter. NO<sub>x</sub> emissions also impose health issues, including breathing problems, headaches and reduced lung function<sup>51</sup>.

### 1.8.6.3 Future Direction of Biomass

As biomass is a finite supply, it is crucial to prioritise optimum use of biomass. The Climate Change Committee report 'Biomass in a Low-Carbon Economy'<sup>52</sup> states that harvested biomass should be used to sequester atmospheric carbon whilst simultaneously providing a useful energy service. This means that the use of biomass for heating buildings or using biomass for generating power without carbon capture and storage should be phased out.

These concerns may mean that the use of biomass is only considered in limited circumstances.

### 1.8.6.4 Incineration (Energy from Waste)

Incineration can be defined as the controlled thermal treatment of waste by burning. Energy recovered from waste through this method can be used in the following ways:

- Generation of Power (electricity);
- Generation of Heat; and
- Generation of Heat and Power (this is referred to as CHP<sup>53</sup>).

However, EfW is almost always from a bespoke plant that produces both power and heat. The system could generate heat from sources including waste wood, municipal waste and industrial and commercial waste. However, the selection of energy generation option is dictated by end-user requirements and their utilisation of the heat and/or power.

Option three above includes a CHP for simultaneous generation of heat and power. The power can be consumed on-site or exported and sold to the national grid. Local heat demand and a dedicated heat network is required for the generated heat unless all the available heat can be used in the generating facility.

Any new centralised electricity plant is likely to be required to have higher thermal efficiency and linked in with some process to use heat (e.g. steam, waste treatment, etc.).

### 1.8.6.5 Anaerobic Digestion

Anaerobic Digestion (AD) can be defined as:

---

*“a series of processes in which microorganisms break down biodegradable material in the absence of oxygen. It is used for industrial or domestic purposes to manage waste and/or to release energy. Much of the fermentation used industrially to produce food and drink products, as well as home fermentation, uses anaerobic digestion<sup>54</sup>”*

---

<sup>51</sup> [https://uk-air.defra.gov.uk/assets/documents/reports/cat11/1708081027\\_170807\\_AQEG\\_Biomass\\_report.pdf](https://uk-air.defra.gov.uk/assets/documents/reports/cat11/1708081027_170807_AQEG_Biomass_report.pdf)

<sup>52</sup> Climate Change Committee, 'Biomass in a Low-Carbon Economy, 2018; <https://www.theccc.org.uk/wp-content/uploads/2018/11/Biomass-in-a-low-carbon-economy-CCC-2018.pdf>

<sup>53</sup> [https://assets.publishing.service.gov.uk/government/uploads/system/uploads/attachment\\_data/file/221036/pb13889-incineration-municipal-waste.pdf](https://assets.publishing.service.gov.uk/government/uploads/system/uploads/attachment_data/file/221036/pb13889-incineration-municipal-waste.pdf)

<sup>54</sup> [https://assets.publishing.service.gov.uk/government/uploads/system/uploads/attachment\\_data/file/284612/pb14130-energy-waste-201402.pdf](https://assets.publishing.service.gov.uk/government/uploads/system/uploads/attachment_data/file/284612/pb14130-energy-waste-201402.pdf)

The AD process produces a gas (biogas) with a high methane content. This methane can be captured and burned to produce heat and/or electricity and utilised as a transport fuel. The material that is left after AD occurs is called “digestate”, a nitrogen-rich mixture that can be used as fertiliser for crops. AD plants utilise heat for their own process (parasitic load); therefore, some of the biogas can be used on-site to maintain the temperature of the digester.

Sewage sludge, farm slurry, and some Municipal Solid Waste (MSW) elements could be used as feedstock for an AD plant to generate gas and/ heat and electricity if CHP enabled.

AD can be incorporated in a farm-based integrated waste management system, but larger-scale centralised anaerobic digesters also exist, which use feedstocks imported from different sources. The larger schemes usually have a better return on investment and shorter payback times which justifies the initial capital cost required for the system. AD systems often require bulk inputs to be economically viable, but this can be challenging when sourcing material from dispersed (rural) locations. Once built, ADs are often linked to on-farm processes, energy supply, and the grid. Figure 23 shows an example of an AD plant configured to produce energy and bio-fertiliser from biowaste feedstock.

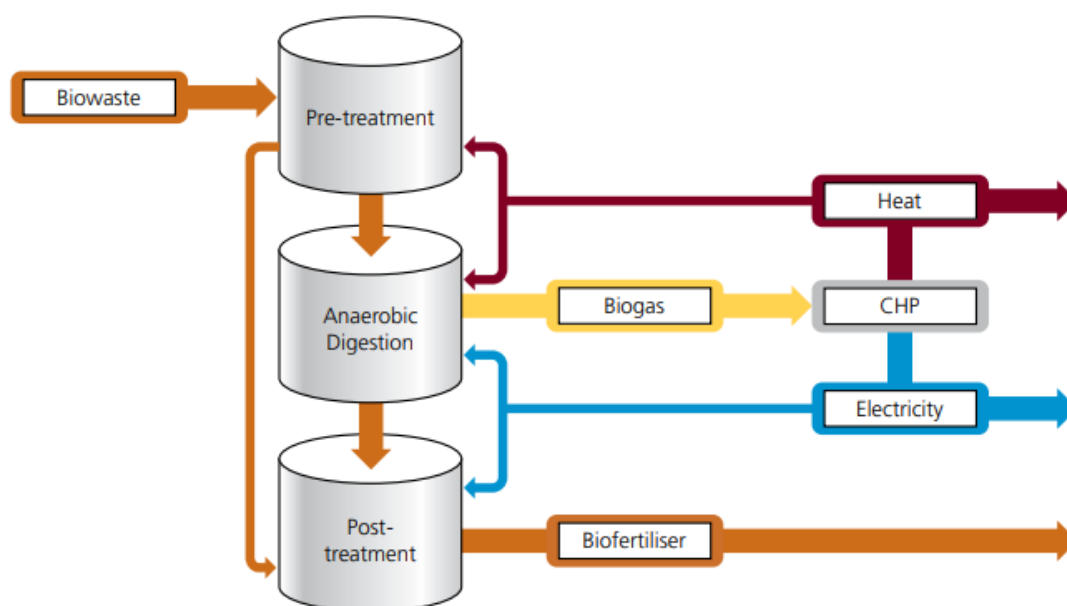

Figure 23: Example of an Anaerobic Digestion (AD) System from Feedstock to Final Use<sup>55</sup>

#### 1.8.6.6 Landfill Gas

Landfill Gas is the methane-rich gas released from biodegradable waste as it decomposes. Landfill gas can be captured through vertical pipes drilled into a capped site.

Landfill gas can be used to generate electricity that can be exported to the electricity grid.

#### 1.8.7 Marine Renewable Technologies

There are many forms of marine energy generation; however, the two forms of marine energy that are relevant to this study and mentioned in the South West Marine Plan<sup>56</sup> due to their significant resources are:

<sup>55</sup> [https://assets.publishing.service.gov.uk/government/uploads/system/uploads/attachment\\_data/file/69400/anaerobic-digestion-strat-action-plan.pdf](https://assets.publishing.service.gov.uk/government/uploads/system/uploads/attachment_data/file/69400/anaerobic-digestion-strat-action-plan.pdf)

<sup>56</sup> [https://assets.publishing.service.gov.uk/government/uploads/system/uploads/attachment\\_data/file/857299/DRAFT\\_SW\\_Marine\\_Plan.pdf](https://assets.publishing.service.gov.uk/government/uploads/system/uploads/attachment_data/file/857299/DRAFT_SW_Marine_Plan.pdf)

- Tidal Energy – Tidal energy uses the natural rise and fall of the sea tides and currents to generate energy. There are three main methods to get tidal energy. Tidal streams, where a turbine is situated in a tidal stream. Barrages, where water flows over the top of a barrage or through turbines within the barrage. Moreover, tidal lagoons, where a barrier partially encloses a body of ocean. The turbine rotates as the lagoon fills and drains.
- Offshore Wind Energy – Offshore wind energy is the installation of wind turbines offshore. Offshore wind energy provides the advantage over onshore wind energy due to the lack of obstacles resulting in reduced wind speed; this means that more of the wind can be harnessed. The CCC report “Reducing UK emissions June 2020” states that offshore wind is now the fastest growing form of electricity generation in the UK<sup>57</sup>.

The marine licensing system for tidal power in the United Kingdom is complex. In general, consent from the Marine Management Organisation (MMO) is required to construct, extend, or operate any offshore generating stations with a capacity between 1 and 100MW (Section 66 of the Marine and Coastal Access Act 2009<sup>58</sup>; Section 36 of the Electricity Act 1989<sup>59</sup>). Safety zone consents may also be required (Section 95 of the Energy Act 2004<sup>60</sup>).

Stations that would generate more than 100MW are classified as Nationally Significant Infrastructure Projects (NSIPs) and require a Development Consent Order (DCO) granted by the Secretary of State. The local planning authority for each region permits onshore planning and the Department for Business, Energy and Industrial Strategy (DBEIS) regulates the decommissioning of projects under Energy Act 2004.

The development of hydrokinetic turbines for river arrays means that energy can now be generated relatively efficiently with minimal impacts to the shape and behaviour of river channels, opening up the possibility for more sustainable energy production in large rivers with active sediment transport. However, such installations are likely to be small-scale (5-50kW), non-economic when compared with other renewables and the calculation of theoretically installed capacity complex, hence the exclusion of projections within this RERAS. It should be noted that large scale marine renewable technologies (e.g. tidal stream devices, tidal range barriers and lagoons, and wave energy conversion devices) are excluded from this assessment as decisions about such development are outside of the Council's jurisdiction.

### 1.8.8 Low Carbon Energy Options

Low carbon energy options cover a range of energy sources that are not renewable but can still produce less carbon than using conventional electricity grid or gas networks. Therefore, they are considered an important part of decarbonising the energy supply. These options include the following, which are considered further in Section 1.8.8.1 to 1.8.8.2;

- Waste heat, e.g. from power stations or industrial processes;
- The non-biodegradable fraction of the output from EfW plants.

#### 1.8.8.1 Waste Heat

Waste heat generally refers to the heat generated by an industrial process that would have otherwise been wasted if it was not recovered and reused. The heat can be reused in different ways, including usage on-site or by another end-user (e.g. through a heat network) or converting the waste heat to power<sup>61</sup>. Such heat can be considered a low carbon option as it offsets the new end-user's need for additional heating fuel.

<sup>57</sup> <https://d423d1558e1d71897434.b-cdn.net/wp-content/uploads/2020/06/Reducing-UK-emissions-Progress-Report-to-Parliament-Committee-on-Cli...-002-1.pdf>

<sup>58</sup> [https://assets.publishing.service.gov.uk/government/uploads/system/uploads/attachment\\_data/file/490998/Marine\\_and\\_Coastal\\_Access\\_Act\\_2009\\_Energy\\_Bill\\_2015-16\\_Keeling\\_Schedule\\_.pdf](https://assets.publishing.service.gov.uk/government/uploads/system/uploads/attachment_data/file/490998/Marine_and_Coastal_Access_Act_2009_Energy_Bill_2015-16_Keeling_Schedule_.pdf)

<sup>59</sup> [https://assets.publishing.service.gov.uk/government/uploads/system/uploads/attachment\\_data/file/490992/Electricity\\_Act\\_1989\\_Energy\\_Bill\\_2015-16\\_Keeling\\_Schedule\\_.pdf](https://assets.publishing.service.gov.uk/government/uploads/system/uploads/attachment_data/file/490992/Electricity_Act_1989_Energy_Bill_2015-16_Keeling_Schedule_.pdf)

<sup>60</sup> [https://assets.publishing.service.gov.uk/government/uploads/system/uploads/attachment\\_data/file/490993/Energy\\_Act\\_2004\\_Energy\\_Bill\\_2015-16\\_Keeling\\_Schedule\\_.pdf](https://assets.publishing.service.gov.uk/government/uploads/system/uploads/attachment_data/file/490993/Energy_Act_2004_Energy_Bill_2015-16_Keeling_Schedule_.pdf)

<sup>61</sup> [https://assets.publishing.service.gov.uk/government/uploads/system/uploads/attachment\\_data/file/651125/IHRS\\_Consultation\\_Document-October\\_2017.pdf](https://assets.publishing.service.gov.uk/government/uploads/system/uploads/attachment_data/file/651125/IHRS_Consultation_Document-October_2017.pdf)

### 1.8.8.2 The Non-Biodegradable Fraction of the Output from Energy from Waste Plants.

Section 1.8.6 includes details of the EfW as a renewable technology. However, in the case where the waste is used as fuel includes materials that are not capable of being degraded by plants and animals, the fraction of heat output generated due to the incineration of these wastes is considered low carbon.

### 1.8.9 Hydrogen

Hydrogen is included under a separate subheading because it can be produced using renewable electricity or high temperature heat.

Hydrogen can be produced through several methods, but the main two options are explained in this section.

1. Steam Methane Reforming (SMR) – In this method, hydrogen is produced from a methane source, such as natural gas, via a high-temperature process. Hydrogen generated via this process is considered low carbon (not zero-carbon) only if a carbon dioxide capture and storage system (CCS) is utilised; this is known as ‘blue hydrogen’<sup>62</sup>.

---

*“Carbon dioxide capture and storage is a process consisting of the separation of CO<sub>2</sub> from industrial and energy-related sources, transport to a storage location and long-term isolation from the atmosphere”*

---

The SMR method is a fully developed commercial process, and currently, it is the dominant technology used to produce hydrogen.

2. Electrolysis – Electrolysis is the process of using electricity to split water into hydrogen and oxygen. Renewable electricity can be used in an electrolysis plant to generate ‘green hydrogen’.

The production and use of hydrogen is generally less efficient than electrification, but hydrogen is more readily storable than electricity at a very large scale. In relation to this, the Hydrogen in a Low Carbon Economy<sup>63</sup> report by the CCC states:

---

*“...hydrogen has particular value as a low-carbon replacement for natural gas (and potentially oil) in applications where full electrification is very difficult, disruptive and/or expensive”*

---

Hydrogen can be utilised as:

- a heating fuel in homes or industry;
- large scale power generation<sup>64</sup>; and
- fuel for hydrogen fuel cell vehicles, especially for heavy-duty vehicles (e.g. buses, trains and lorries)<sup>63</sup>.

As the CCC report confirms, low or zero-carbon hydrogen can be a valuable complement to electrification in reducing energy use emissions.

The Regen Hydrogen Insight Paper<sup>65</sup> states that as the energy density by volume of hydrogen (3.3 kWh per cubic metre) is much lower compared to that of natural gas (11 kWh per cubic metre), hydrogen requires compressing to a much higher pressure and delivering at a higher flow rate, in order to deliver the same energy content. This creates complications in the transport and storage of

---

<sup>62</sup>[https://www.ipcc.ch/site/assets/uploads/2018/03/srccs\\_wholereport-1.pdf](https://www.ipcc.ch/site/assets/uploads/2018/03/srccs_wholereport-1.pdf)

<sup>63</sup> <https://www.theccc.org.uk/wp-content/uploads/2018/11/Hydrogen-in-a-low-carbon-economy.pdf>

<sup>64</sup> Hydrogen can replace natural gas to have back-up role in the future electricity grid.

<sup>65</sup> Building the Hydrogen Value Chain, Regen, 2021 (<https://www.regen.co.uk/wp-content/uploads/Hydrogen-Insight-Paper-v4.pdf>)

hydrogen. Due to this, the initial market driver for hydrogen is towards production plants located within industrial and chemical process clusters and transport hubs with short or onsite distribution channels.

Although the cost of blue and green hydrogen is currently high compared to its competitors (natural gas and 'grey' hydrogen), the insight paper suggests that it is predicted that the price will reduce considerably over the coming decade due to the economies of scale and innovation.

#### 1.8.10 Nuclear Fusion

Nuclear fusion is the production of energy through two small atoms combining to form one larger atom. During this process, mass is lost, and energy is gained. This energy is released in the form of a fast-moving particle called a neutron. The kinetic energy of the neutron is converted into heat. This heat is used to produce steam, which is used to power turbines and alternators and, in turn, produce electricity, see Figure 24<sup>66</sup>. Fusion has a significant potential to be a long-term energy source that is environmentally responsible (with no carbon emissions). Traditional nuclear fission power plants have the disadvantage of generating unstable nuclei; some of these are radioactive for millions of years. Nuclear fusion on the other hand, does not create any long-lived radioactive nuclear waste.

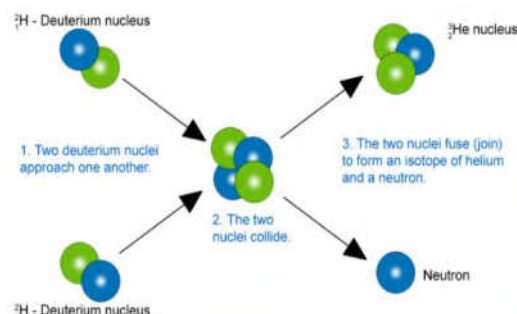

Figure 24: Nuclear Fusion Diagram<sup>66</sup>

Energy production by nuclear fusion is not yet commercially available; however, the UK Government's Ten Point Plan for a Green Industrial Revolution<sup>67</sup> outlines ambitions to be the first country in the world to commercialise fusion energy technology. The plan outlines the aim to build the world's first commercially viable fusion power plant in the UK by 2040.

Western Gateway has submitted a bid proposing that a technology park and power plant be located at two former nuclear power station sites in Oldbury and Berkeley<sup>68</sup>. The bid correlates with the Ten Point Plan for a Green Industrial Revolution with an expected operational date of 2040. The UK Atomic Energy Authority (UKAEA) will assess the nominated sites and produce a shortlist of three selected sites for submission to the secretary of state for business energy and industrial strategy.

<sup>66</sup> [http://resources.hwb.wales.gov.uk/VTC/2008-09/science/irf08\\_48/Images/Nuclear-fusion.jpg](http://resources.hwb.wales.gov.uk/VTC/2008-09/science/irf08_48/Images/Nuclear-fusion.jpg)

<sup>67</sup> The Ten Point Plan for a Green Industrial Revolution, HM Government, November 2020; [https://assets.publishing.service.gov.uk/government/uploads/system/uploads/attachment\\_data/file/936567/10\\_POINT\\_PLAN\\_B\\_QOKLET.pdf](https://assets.publishing.service.gov.uk/government/uploads/system/uploads/attachment_data/file/936567/10_POINT_PLAN_B_QOKLET.pdf)

<sup>68</sup> <https://www.insidermedia.com/news/south-west/land-nominated-for-fusion-power>

### 1.8.11 Power vs Energy Output

In the context of this Renewable Energy Resource Assessment Study, power and heat are measured in either:

**Kilowatts (kW);  
Megawatts (MW), which is one thousand kW; or  
Gigawatts (GW), which is a thousand MW.**

These are a measure of the electricity or heat output being generated (or used) at any given moment in time. When it is running at full load, the maximum output of a generator is referred to as its installed capacity or rated power/heat output.

Energy, on the other hand, is the product of power and time. It has kWh units (the h stands for "hour") or MWh, or GWh. As an example, if a 2MW wind turbine ran at full power for 1 hour, it would have generated  $2 \times 1 = 2\text{MWh}$  of energy. If it ran at full power for one day (24 hours), it would have generated  $2 \times 24 = 48\text{MWh}$ .

This distinction is essential because in carrying out the RERAS, certain assumptions have been made to calculate both the potential installed capacity (or maximum power output) of different technologies and the potential annual energy output.

### 1.8.12 Electricity vs Heat Output

In terms of the units used, it is important to distinguish whether a generator is producing electricity or heat to avoid confusion. This is because some renewable energy fuels (i.e. biomass) can be used to produce either heat only or electricity and heat simultaneously when used in a CHP plant.

It is also important to be able to distinguish between renewable electricity targets and renewable heat targets

**The suffix "e" is added to denote electricity power or energy output, e.g. MWe, or MWhe,**

**The suffix "t" is used (for "thermal"), to denote heat output, e.g. MWt, or MWht**

..



## 2. Policy Context and Drivers for Renewable Energy

Table 6 contains a summary of the key regulations, policies and strategies that drive and support the development of renewable energy and low carbon technologies internationally, nationally and at a local level. Greater detail on each of the policies is included in Appendix A.

**Table 6: Policy and Drivers Summary**

International & National Policy, Strategy and Guidance	
The Kyoto Protocol (1998)	An international treaty with the collective goal of preventing dangerous anthropogenic interference with the climate system.
The Paris Agreement (2016)	Over 190 countries adopted the global action plan to limit the effects of climate change by limiting global warming to well below 2°C and pursuing efforts to limit it to 1.5°C.
The UK Climate Change Act (2008)	A national legally binding target for the UK to reduce its emissions by 100%, compared with the 1990 baseline, by 2050 (increased from 80%).
National Planning Policy Framework (2021) (NPPF)	Overarching planning guidance in England, setting out the Government's planning policies and guidance on how these policies should be applied.  <i>The NPPF states that "the planning system should support the transition to a low carbon future in a changing climate, taking full account of flood risk and coastal change. It should help to: shape places in ways that contribute to radical reductions in greenhouse gas emissions, minimise vulnerability and improve resilience; encourage the reuse of existing resources, including the conversion of existing buildings; and support renewable and low carbon energy and associated infrastructure".</i>
UK National Energy and Climate Plan (2019) (NECP)	The NECP is the framework by which European Union Member States* are required to set out their integrated climate and energy objectives, targets, policies and measures, covering the 5 dimensions of the Energy Union for the period 2021 to 2030.  <i>*Following the exit of the UK from the EU, the UK was subject to EU legislation during the Brexit transition and so the UK NECP was submitted shortly before the end of 2020</i>
UK Industrial Strategy (2017)	Strategy providing emphasis on the need for clean growth in order to boost economic prosperity within the UK. Some of the stated aims of the Industrial Strategy relevant to energy use in the built environment include increasing the delivery of new homes, decarbonising the heat supply, and lowering emissions from the transport sector. The strategy is now archived, and it is currently being replaced by Build Back Better: our plan for growth <sup>69</sup> policy.
England Resource and Waste Strategy (2018)	Strategy setting out how England will preserve material resources by minimising waste, promoting resource efficiency and moving towards a circular economy. Plans to encourage the reduction and increased management of waste through policies to support reuse, repair and remanufacture activities and by tackling waste crime.
Waste Management Plan for England (2021)	Strategy setting out the Government's ambition to work towards a more sustainable and efficient approach to resource use and management.
National Planning Policy for Waste (2014)	Details the implementation of waste policies across England's local authorities through the demand, suitability and ability to monitor waste management facilities.
Clean Growth Strategy (2017)	A strategy that sets out the UK Government's ambitious policies and proposals, through to 2032 and beyond for decarbonising all sectors of the UK economy.

<sup>69</sup> <https://www.gov.uk/government/publications/build-back-better-our-plan-for-growth>

25 Year Environmental Plan (2018)	A plan building on the proposals and policies outlined in the Clean Growth Strategy and aims to improve the environment within a generation and leaving it in a better state than we found it. It details how the government will work with communities and businesses to do this.
The UK Heat Strategy (2013)	Establishes a strategic framework for the transition to a low carbon heat supply.
Building Regulations in England (Part L and Part F) (2021 <i>under consultation</i> )	Regulations setting the minimum standards for building performance that must be met for a building to be approved for construction. Part L of the Building Regulations focuses on the conservation of heat and power and sets specific requirements for the fabric performance, building services efficiency, overheating and CO <sub>2</sub> emissions, and Part F contains guidance on the building ventilation.
Ten Point Plan for a Green Industrial Revolution (2020)	Plan detailing how the UK intends to kick-start a green industrial revolution. Following the economic collapse induced by the coronavirus pandemic.
Offshore Wind Sector Deal (2020)	A deal that accentuates the partnership between the Government and the offshore wind sector, including the details of the investments into the sector, including the plans to provide funding to allow for 40GW (increased from the 30GW set out in the original deal).
<b>Emerging National Policy</b>	
Environmental Bill (2020)	The Environment Bill aims to manage the impact of human activity by creating a more sustainable and resilient economy, following on from the 25 Year Environment Plan.
Energy White Paper 'Powering our Net Zero Future' (2020)	Provides further clarity on the Ten Point Plan and highlights the long-term strategy for the wider energy system that transforms energy, supports green recovery and creates a fair deal for consumers, consistent with the target for net zero emissions by 2050.
Planning White Paper: 'Planning for the Future' (2021 <i>under consultation</i> )	A proposal aiming to reform the planning system in England, creating an efficient and modernised planning process that focuses on design and sustainability, improves developer contributions to infrastructure, and ensures land is available for development.
<b>Financial Incentive Schemes</b>	
Renewable Heat Incentive (RHI)	A Government environmental programme to support renewable heat delivered to homes or non-domestic buildings. RHI provides incentives for consumers to install renewable heating in place of fossil fuels, open to homeowners and landlords, commercial, industrial, public, not-for-profit and community generators of renewable heat.
Energy Company Obligation (ECO)	Under this scheme, energy companies are obligated to promote and support carbon emissions reductions to customers.
Smart Export Guarantee (SEG)	The scheme requires licensed electricity suppliers to offer at least one export tariff, which must always be above zero and makes payment to small-scale low-carbon generators for electricity exported to the National Grid.
Heat Networks Delivery Unit	Provides grant funding and guidance to local authorities in England and Wales for heat network feasibility studies.
Green Heat Network Fund (GHNF)	A Government funding programme which is intended to help new and existing heat networks to move to low and zero carbon technologies.

## West of England Policy

---

The West of England Joint Waste Core Strategy (2011)	Strategic spatial planning policy to provide waste management infrastructure across the plan area. The joint strategy covers four councils of Bath and North East Somerset, Bristol, North Somerset and South Gloucestershire, and it applies to all waste, except for most radioactive waste the policy for which is dealt with at a national level.
The West of England Local Industrial Strategy (2019)	Strategy conveying the importance of minimising the impact on the environment when implementing the region's four main priorities: cross-sectoral innovation; inclusive growth; addressing the productivity challenge; and delivering innovation in infrastructure delivery.

## South Gloucestershire Local Policy

---

Core Strategy (2013)	Set out the overall development strategy for South Gloucestershire and the strategic planning policies to deliver it.
Policies, Sites and Places Plan (2017)	Forms part of the South Gloucestershire Local Plan and sits alongside the Core Strategy. It was adopted in 2017 and comprises of a suite of development management policies, and details about site allocations.
South Gloucestershire Resource and Waste Strategy: 2020 and Beyond (2020)	A strategy focusing on reducing the production of waste, with a focus on reducing the use of single-use items and encouraging re-use and repair. The strategy aims to increase awareness of and improve on; the value of the resource, addressing plastics, reducing waste, re-use, recycling and the role of recovery.
Supplementary Planning Document: Renewables (2014)	Planning document encouraging local community engagement with proposed renewables projects and provides guidance for community-led projects to help secure delivery of renewables targets and technologies in South Gloucestershire.
South Gloucestershire Climate Emergency Strategy (2020)	10-year lifespan strategy explaining the Council's principles and general approach to delivering the aim of South Gloucestershire being carbon neutral by 2030.

## 3. Baseline Energy Consumption and Low and Zero Carbon Energy Technologies in South Gloucestershire

### 3.1 Introduction

This section of the RERAS outlines the baseline energy consumption and existing Low and Zero Carbon (LZC) energy technologies in South Gloucestershire, using the latest available data (2018 - published on September 2020). Establishing the baseline consumption and the existing LZC energy technologies provides an understanding of the progress being made in South Gloucestershire and enables a calculation of what remains to be done in order to meet aims.

The indicative heat demand and electricity consumption maps were created based on the published data from the Office for National Statistics using Middle Layer Super Output Areas (MSOA). MSOA is a geographic hierarchy designed to improve the report of statistics in small areas in England and Wales. The Organisation Data Service publishes files created by the Office for National Statistics, linking the postcodes to the MSOA. These maps provide a visual representation of the varying heat and electricity consumption across South Gloucestershire.

The existing LZC energy technologies map includes technologies generating electricity, heat and both electricity and heat simultaneously. The assessment includes 'stand-alone' generators (such as wind farms) as well as those installed in buildings (e.g. biomass boilers). Energy from Waste (EFW) schemes and biomass schemes have also been marked for their potential contribution to supply heat to strategic new development sites. The existing LZC energy technology maps show existing, consented and sites under construction. The information regarding these existing technologies has been provided by:

- Regen<sup>70</sup>;
- Renewable Heat Incentive (RHI) data;
- Feed-in Tariffs (FIT) data;
- Renewables Obligation database (RO);
- Renewable Energy Guarantees of Origin database (REGO);
- Additional data provided by Regen on large renewable generators in South Gloucestershire;
- South Gloucestershire renewable energy progress report;
- Renewable Energy Planning Database (REPD); and
- Any additional wind turbines that are identified from the planning data.

### 3.2 Baseline Energy Consumption in South Gloucestershire in the Baseline Year

Map Reference and Title:

1. E1-SG: Indicative Heat Demand Based on Gas Consumption – Total Gas Consumption by MSOA in 2019 (MWh per Year)
2. E2-SG: Total Electricity Consumption by MSOA in 2019 (MWh per Year)

The Department for Business, Energy and Industrial Strategy (BEIS) of the UK Government (formerly the Department for Energy & Climate Change (DECC)) publishes annual energy consumption (GWh) at a sub-national level. Regen has analysed the latest available data (2018)<sup>71</sup> and provided a breakdown of the current energy consumption in South Gloucestershire, illustrated in Table 7.

<sup>70</sup> A non-profit organisation which promotes renewable energy and energy efficiency within the UK

<sup>71</sup> Sub-national total final energy consumption statistics - 2018 (published on September 2020); <https://www.gov.uk/government/statistics/total-final-energy-consumption-at-regional-and-local-authority-level-2005-to-2018>

**Table 7: Existing Energy Consumption (GWh) in South Gloucestershire (2018)<sup>72</sup>**

	Current Energy Consumption (GWh)
Domestic Buildings Fossil Fuels and Renewables Energy Consumption for Heating	1,473.0
Domestic Buildings Electricity Consumption for Heating	111.4
Domestic Buildings Non-Heating Electricity Consumption	323.0
Commercial and Industrial Buildings Fossil Fuels and Renewables Energy Consumption for Heating	1,045.1
Commercial and Industrial Buildings Electricity Consumption for Heating	86.3
Commercial and Industrial Buildings Non-Heating Electricity Consumption	653.2
Transport Sector Other Fuels Consumption	3,365
Transport Sector Electricity Consumption	11.6
Total Heat Demand (Including Electrical Heating Consumption)	2,715.8
Total Electricity Consumption (Including Electrical Heating Consumption and Transport Sector Electricity Consumption)	1,185.6
Total Transport Sector Energy Consumption	3,376.6
<b>Total Energy Consumption</b>	<b>7,069</b>

According to Table 7, South Gloucestershire consumed 7,069GWh of energy over the course of 2018. Of this, domestic buildings' energy consumption accounts for about 1,907GWh, C&I sector 1,785GWh and transport sector 3,377GWh of the total consumption.

Total electricity consumption across South Gloucestershire was 1,185.6GWh in 2018, including 198GWh of electric heating and 11.6GWh for electric vehicles. The total figure is circa 0.5% of England's total reported electricity consumption in 2018.

Total heat demand across South Gloucestershire was 2,716GWh in 2018. Of this, 198GWh was met via electrical heating, and the remaining heat demand, which was met by fuels other than electricity, was 2,518GWh. Figure 27 below illustrates energy demands across different sectors in South Gloucestershire.

The E1 and E2 maps illustrate total indicative heat and electricity consumption based on natural gas consumption by MSOA respectively. The darker the coloured area on the map, the higher the gas or electricity consumption by middle layer super output areas in 2019 (MWh per year) for maps E1 and E2 respectively. Screenshots have been provided in the report as a visual aid. Higher resolution versions of these maps are contained in the accompanying document 'South Gloucestershire RERAS – Maps'.

<sup>72</sup> Sub-national total final energy consumption statistics - 2018 (published on September 2020); <https://www.gov.uk/government/collections/total-final-energy-consumption-at-sub-national-level> and Regen analysis.

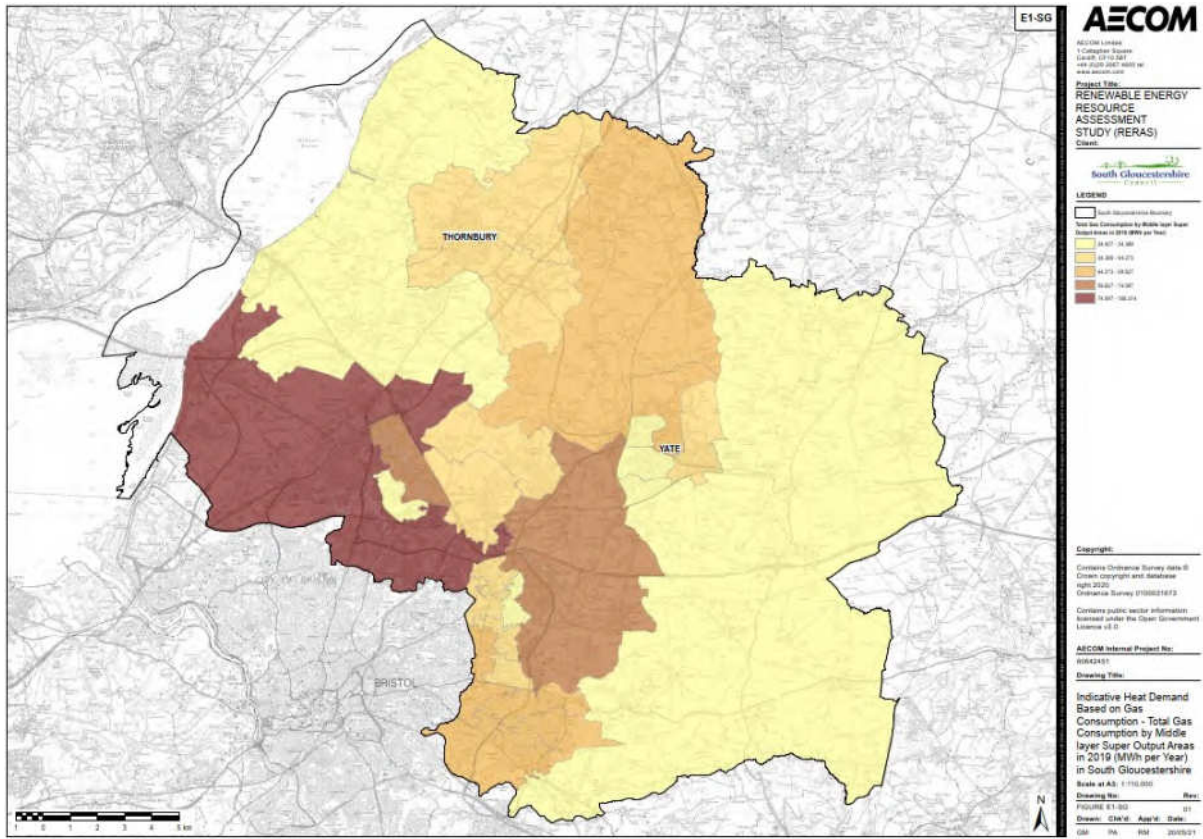

Figure 25: E1-SG: Indicative Heat Demand Based on Gas Consumption – Total Gas Consumption by MSOA in 2019 (MWh per Year) Map

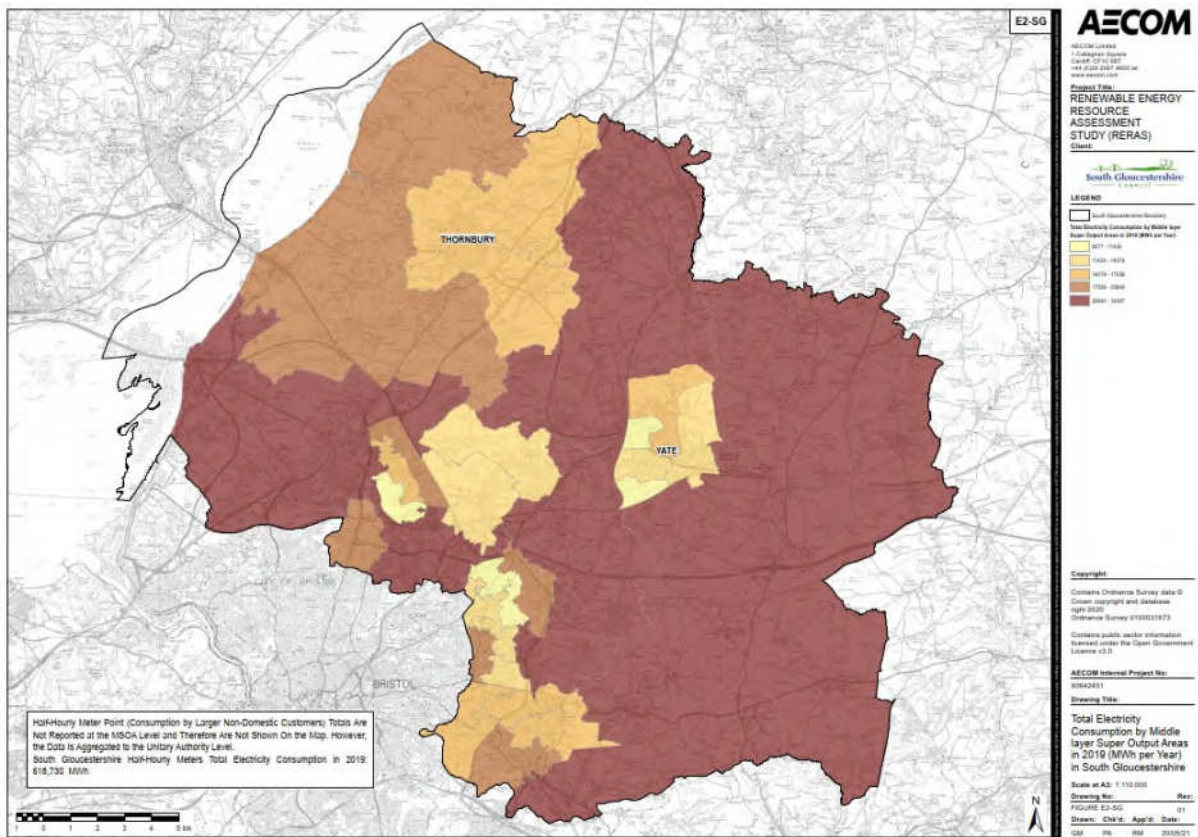

Figure 26: E2-SG: Total Electricity Consumption by MSOA in 2019 (MWh per Year) Map

Breakdown of Current Energy Demand in South Gloucestershire (GWh)

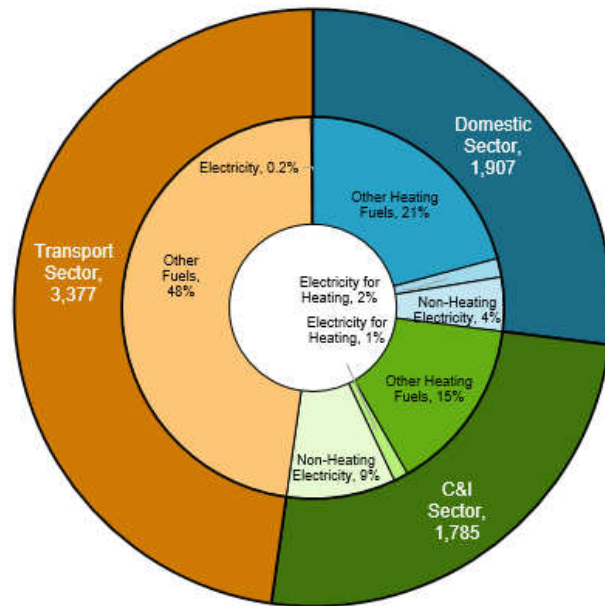

Figure 27: Breakdown of Existing Energy Consumption (GWh) in South Gloucestershire

When comparing South Gloucestershire to North Somerset and Bath and North East Somerset, South Gloucestershire consumed the greatest amount of energy over the course of 2018, with North Somerset and Bath and North East Somerset following respectively (see Figure 28). The significant differences in energy consumption is likely due to the difference in population density and the rurality of each council.

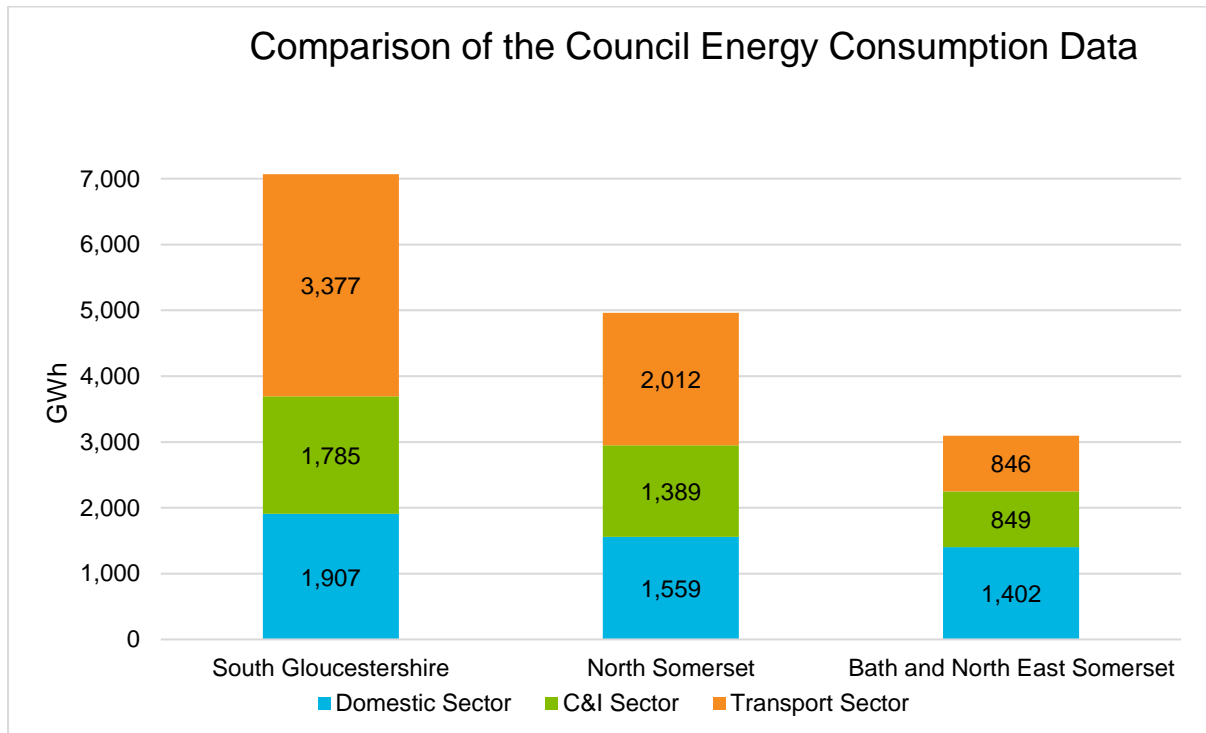

Figure 28: Chart Showing Comparison of Energy Consumption Data for the Councils Considered

South Gloucestershire is the most populated of the abovementioned three areas in terms of absolute total number; however, it is the most sparsely populated (it has the lowest population density). Conversely, Bath and North East Somerset has the lowest population but is the most densely populated.

Low population density has given rise to much higher transportation energy consumption in South Gloucestershire than the other areas, due to a heavier reliance on commuting. The greater rurality of South Gloucestershire and North Somerset also gives rise to more energy consumed from farm machinery.

There is little difference between the thermal and electrical energy consumption of the three authorities, although South Gloucestershire has the highest consumption levels, which is due to a greater population and higher number of enterprises.

### 3.3 Existing Capacity of Low and Zero Carbon Energy Technology Installations and Energy Generation in South Gloucestershire

Map References & Titles:

#### 1. R1-SG: Sites of Existing Renewable Energy in South Gloucestershire

To understand the progress being made with the development of LZC technologies, the existing capacity (as of 18/01/2021) of LZC technologies in South Gloucestershire was established. Where LZC energy technologies already exist (including developments that are consented to be constructed as well as those already under construction), the installed capacities (measured in MegaWatts (MW)) were recorded to inform discussions about future developments.

This assessment of existing capacity includes technologies generating electricity, heat and both electricity and heat simultaneously. The assessment includes 'stand-alone' generators (such as wind farms) as well as those installed in buildings (e.g. biomass boilers).

The installed capacities of existing Energy from Waste (EfW) schemes and biomass schemes have also been marked for their potential contribution to supply heat to strategic new development sites. The renewable generators have been plotted using Geographic Information System (GIS) mapping, where location details of the sites have been made available.

Regen provided data for existing large-scale projects in South Gloucestershire, shown in Appendix C. The data was cross-checked with BEIS Renewable Energy Planning Database (REPD)<sup>73</sup>, South Gloucestershire planning data, Renewables Obligation (RO) and Renewable Energy Guarantees Origin (REGO) datasets from Ofgem<sup>74</sup>.

Data regarding LZC technologies that are providing energy to buildings located within or on buildings was collected from the following sources:

- Regen;
- Renewable Heat Incentive (RHI) data<sup>75</sup>; and
- Feed-in Tariffs (FIT) data<sup>76</sup>.

The breakdown of technology types for renewable heat generation in domestic and non-domestic buildings is not included in the RHI dataset. Still, the database identifies 55 'non-domestic renewable heat installations with a total installed capacity of 11.26MWt.

The RHI database does not include total installed capacities for domestic installations at the regional level but provides average installation capacities in the UK for different domestic renewable heating technologies. Regen provided a breakdown of the number of existing domestic thermal technologies

<sup>73</sup> BEIS (2020) REPD Monthly Extract; <https://www.gov.uk/government/publications/renewable-energy-planning-database-monthly-extract>.

<sup>74</sup> <https://www.renewablesandchp.ofgem.gov.uk/>

<sup>75</sup> RHI monthly deployment data: January 2021; <https://www.gov.uk/government/statistics/rhi-monthly-deployment-data-january-2021>

<sup>76</sup> Feed-in Tariffs: Quarterly statistics (March 2020)



(heat pump, biomass and solar thermal) in South Gloucestershire in 2020. The average installed capacities are used in conjunction with data provided by Regen to calculate renewable heat generation in domestic buildings.

Additionally, the current renewable energy generators in South Gloucestershire are mapped where location details were available. The map R1-SG is contained in the accompanying document ‘South Gloucestershire RERAS – Maps’. The mapped sites are predominantly large installations from the following datasets, including a few additional small-scale installations.

- Renewables Obligation database (RO);
- Renewable Energy Guarantees of Origin database (REGO);
- Additional data provided by Regen on large renewable generators in South Gloucestershire;
- South Gloucestershire renewable energy progress report;
- Renewable Energy Planning Database (REPD); and
- Any additional wind turbines that are identified from the planning data.

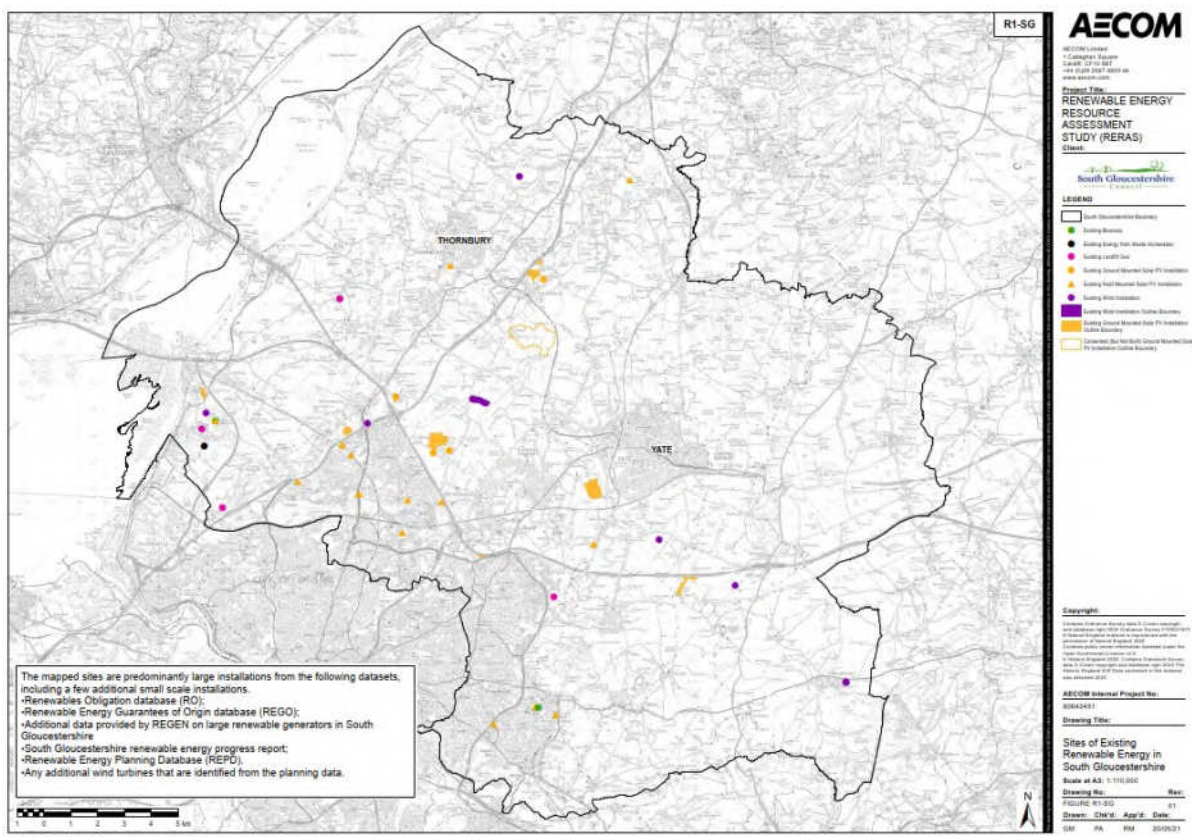

Figure 29: R1-SG: Sites of Existing Renewable Energy in South Gloucestershire

As outlined in Table 8, the total installed capacity of renewable energy generators in South Gloucestershire was calculated as 183.3MWe and 17.6MWt.

**Table 8: Existing Installed Capacity of Renewable Energy Generators in South Gloucestershire (Including Both Those Consented and to be Constructed; and Those Under Construction).**

Technology	Electricity (MWe)	Thermal (MWt)
Hydropower	0.001	0.00
Onshore Wind <6kW (BIR <sup>77</sup> )	0.017	0.00
0.6kW<Onshore Wind <1MW	1.30	0.00
Onshore Wind >=1MW	6.90	0.00
<b>Total Onshore Wind</b>	<b>8.2</b>	<b>0.00</b>
PV-Commercial Rooftop (10kW - 1MW)	9.10	0.00
PV-Ground Mounted (>1MW)	124.40	0.00
PV-Domestic Rooftop (<10kW)	12.78	0.00
<b>Total Solar PV</b>	<b>146.38</b>	<b>0.00</b>
Large Scale Biomass	9.28	0.00
Landfill Gas	9.76	0.00
Waste Incineration <sup>78</sup>	9.67	0.35
Domestic Renewable Thermal Technologies (Heat Pumps)	0.00	2.36
Domestic Renewable Thermal Technologies (Biomass)	0.00	3.45
Domestic Renewable Thermal Technologies (Solar Thermal)	0.00	0.22
Non-Domestic Renewable Thermal Technologies	0.00	11.26
<b>Total</b>	<b>183.3</b>	<b>17.6</b>

Of the above total installed electricity capacity, energy from solar PV accounts for 146.38MWe, landfill gas 9.76MWe and the remaining 27.16MWe is from EfW (Incineration), large scale biomass, wind and hydropower

Of the 17.6MWt installed thermal capacity, non-domestic renewable thermal technologies account for 11.26MWt, domestic thermal heating technologies 6.03MWt and the remaining 0.35MWt is from EfW (incineration).

It should be noted that the large biomass generators and landfill sites installation are large electricity generators.

<sup>77</sup> Building Integrated

<sup>78</sup> The total installed capacity of the Severnside EfW plant is circa 35MWe. However, as only the incineration of the Biodegradable (BD) fraction of feedstock waste could be counted as renewable energy, SUEZ Recycling and Recovery UK Ltd have provided details of proportion of organic waste in the feedstock fuel which is used to calculate renewable capacity of the EfW site.

Figure 30 and Figure 31 below provide a visual representation of the data in Table 8.

Existing Installed Capacity of Renewable Electricity Generators in South Gloucestershire in 2020 (MWe)

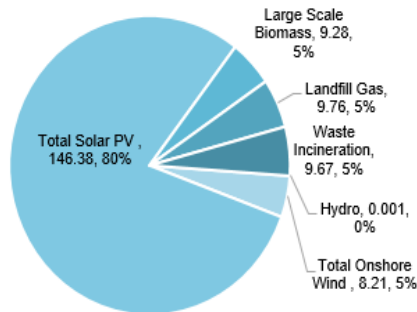

Figure 30: Existing Installed Capacity of Renewable Electricity Generators in South Gloucestershire

Existing Installed Capacity of Renewable Heat Generators in South Gloucestershire in 2020 (MWt)

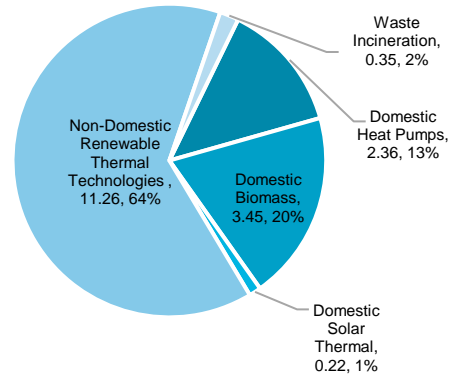

Figure 31: Existing Installed Capacity of Renewable Heat Generators in South Gloucestershire

The maximum amount of energy that could be generated from the above installations depends upon an assumed capacity factor, which is discussed in Section 15. A full table containing the technology, capacity factor, installed capacity and installed generation can be found in Appendix D.

Based on typical capacity factors, the total theoretical generation from existing renewable energy installations in South Gloucestershire at 18/01/2021 is calculated as 333GWh<sub>electricity</sub> (333,233 MWh<sub>e</sub>), and 32GWht<sub>thermal</sub> (31,805 MWht)

Figure 32 shows a comparison of the amount of renewable energy that is currently generated in South Gloucestershire and the current energy consumption across the area.

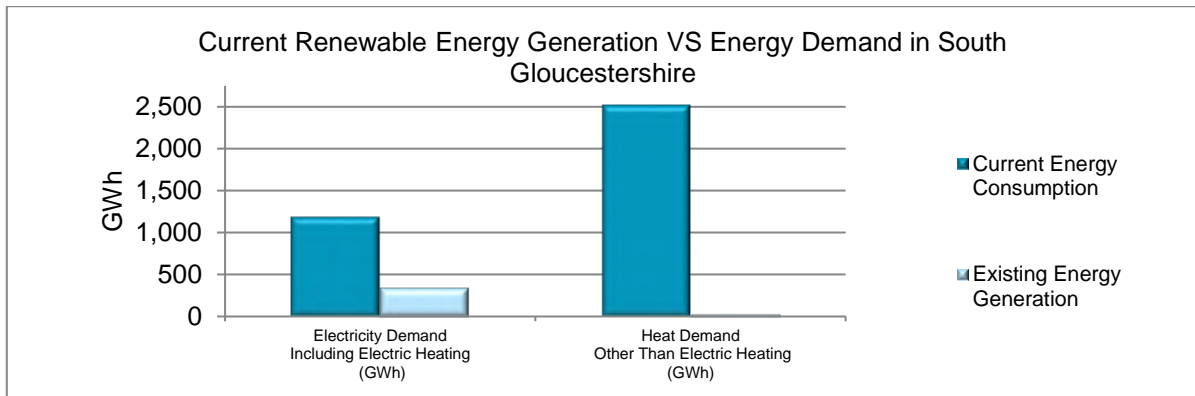

Figure 32: Difference Between the Existing Renewable Energy Generation (GWh) and Current (2020) Energy Consumption. Current Electricity Consumption Includes Electric Heating consumption <sup>79</sup>

There is presently enough installed capacity for electricity generation to meet the equivalent of 28% of local consumption; the consumption data includes 197GWh of electric heating.

The amount of renewable heat generated at present is low, covering only the equivalent of 1% of local demand

<sup>79</sup> Sub-national total final energy consumption statistics - 2018 (published on September 2020); <https://www.gov.uk/government/collections/total-final-energy-consumption-at-sub-national-level> and Regen analysis. The generation data includes sites under construction (consented sites).

## 4. Wind Energy Resource

### 4.1 Introduction

This section of the RERAS focuses on the identification of resource and potential generation from larger scale wind turbines across South Gloucestershire. Information on wind turbines can be found in Section 1.8.1. For this study, the potential for installing wind turbines of 2.5 MW, 1 MW, and 500kW sizes were assessed, and primary constraints associated with wind energy development are considered.

In relation to wind energy, this RERAS is primarily concerned with the spatial identification of potential wind farm developments larger than 5MW total capacity<sup>80</sup>, which is considered the minimum size of a wind farm that could be financially viable without additional incentives<sup>81</sup>. Commercial-scale wind farms seek to install turbines at as large a scale as possible; however, it should be noted that any project (regardless of size) might be of interest to developers and community groups. Therefore, in the interest of completeness, additional suitable areas for installing smaller scale turbines (500kW) are included in the assessment. When assessing a 500kW wind turbine's resources, overlaps with areas suitable for larger turbines were prioritised to the larger turbines.

The different turbine sizes result in varying cut off wind speeds, noise buffers, tip heights and topple distances, and therefore, each of the turbine sizes investigated has been individually mapped. Table 9 below presents the specifications of the wind turbines considered in this study.

**Table 9: Wind Turbines Specifications Used Within This Study**

Turbine Size (Rated Output)	Dimensions	Wind Speed Cut Off	Wind Turbine Density	Approx. Distance Between Turbines	Noise Buffer <sup>82</sup>	Topple Distance Buffer (Tip Height Plus 10%)
2.5 MW	Tip Height <sup>83</sup> : 135 m Rotor Diameter: 100 m Hub Height: 85 m	A lower limit of 5m/s measured at 45m above ground level (agl)	9 MW/km <sup>2</sup>	595 m	600 m	148.5 m
1 MW	Tip Height: 100 m Rotor Diameter: 55 m Hub Height: 60-80 m	A lower limit of 6m/s measured at 45m above ground level (agl)	8 MW/km <sup>2</sup>	399 m	500 m	110 m
500 kW	Tip Height: 70 m Rotor Diameter: 45 m Hub Height: 40-60 m	A lower limit of 6m/s measured at 45m above ground level (agl)	One turbine to be sited on each identified area	One turbine to be sited on each identified area	400 m	77 m

### 4.2 Mapping

The wind resource potential in South Gloucestershire was determined through a series of steps in which the primary constraints associated with wind development have been considered. The datasets corresponding to these constraints are overlaid in GIS maps in stages to produce the Search Areas shown in the RERAS. This assessment considers a combination of primary constraints comprising those that exclude certain places from being considered as potentially suitable as areas of search for

<sup>80</sup> Each 2.5MW and 1.0MW search area can locate a minimum of 5MW wind farm containing 2.5MW or 1.0MW turbines respectively whereas the 500kW search areas can accommodate at least a single 500kW turbine

<sup>81</sup> 5MW was the cut-off point for eligibility of a wind farm to receive subsidies in the Feed-In Tariff (FIT) scheme.

<sup>82</sup> The noise buffers are based on SQW Energy Renewable and Low-Carbon Energy Capacity Methodology – Methodology for the English Regions.

It is understood that the authority may grant planning permission for the construction of a wind turbine generator which does not meet the minimum distance stated in the Bill if the owners of all residential premises which fall within the minimum distance requirement for the proposed wind turbine generator (as stated in the Bill) agree in writing to the construction of the wind turbine generator.

<sup>83</sup> Height to blade tip at the highest point

locating wind farms (e.g., international nature conservation designations), as well as those that require further consideration (referred to as 'other constraints') as part of the Local Plan process (e.g. Areas of Outstanding Natural Beauty (AONB)). For the purposes of this study, these are shown for 'information only' purposes. Each of these different types of constraints, and the stages at which the data layers were applied in the GIS mapping process, was discussed and agreed with the Council.

Maps have been produced to illustrate each stage of the process of identifying primary constraints and opportunities.

The flowchart shown in Figure 33 shows the process steps and the output maps at each stage of the mapping. These maps are contained in the accompanying document 'South Gloucestershire RERAS – Maps'.

For an in-depth, step-by-step explanation of the mapping process, please see Appendix E

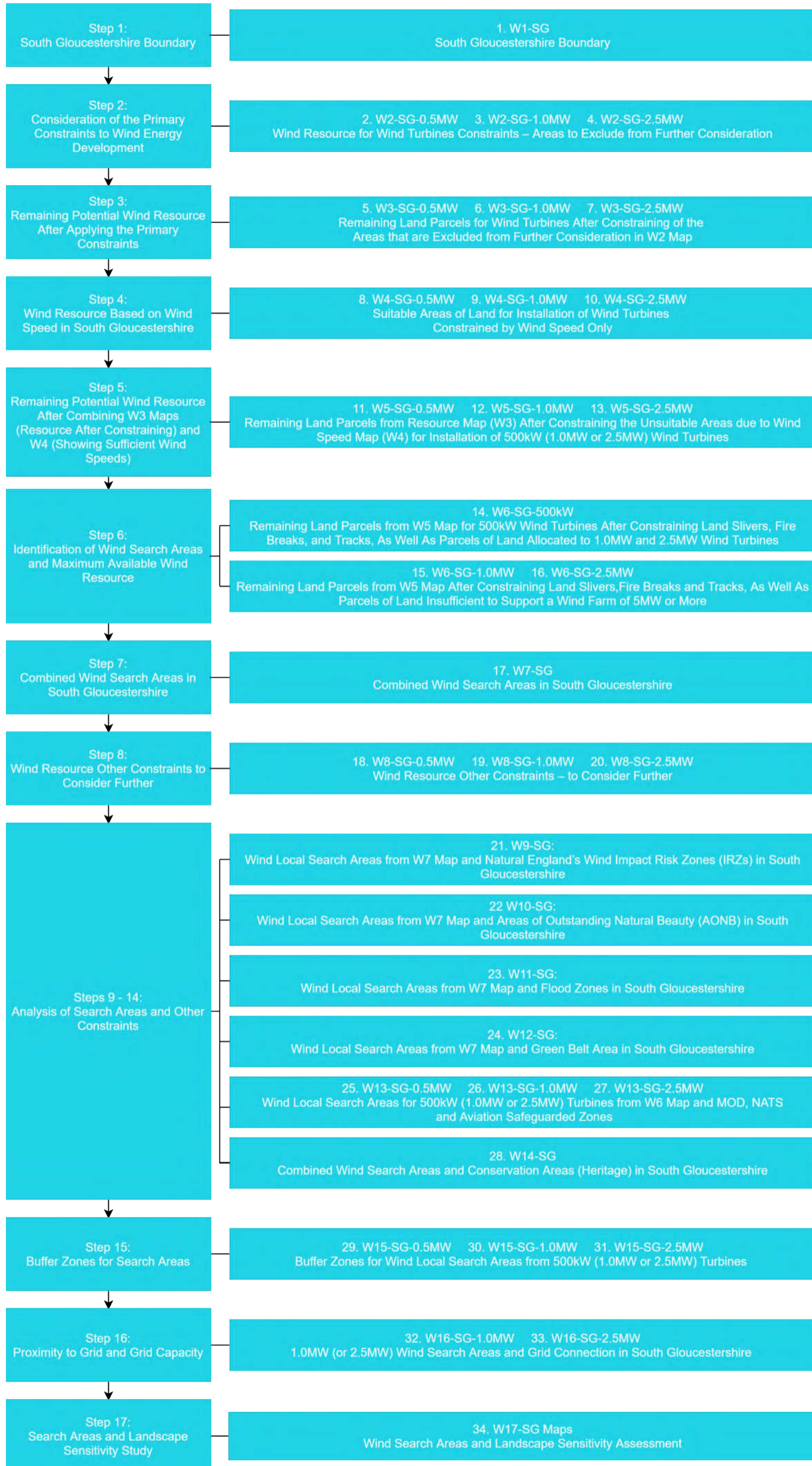

Figure 33: Flowchart of Wind Energy Resource Mapping Process

#### 4.2.1 Primary Constraints

The list below illustrates the primary constraints to the development/ deployment of wind farms. The reason for mapping these areas of constraint is to remove them from consideration in order to produce initial wind farm Search Areas, which can then be refined further through the Local Plan process. Items in brackets indicate that no areas of this type are present in South Gloucestershire. Figure 34 shows these constraints in the South Gloucestershire area. Appendix E and Appendix F include further details regarding this analysis.

- Special Protection Areas (SPA) and foraging buffers;
- Special Areas of Conservation (SAC);
- RAMSAR sites;
- National Nature Reserves (NNR);
- Sites of Special Scientific Interest (SSSI);
- Scheduled Monuments;
- Listed Buildings (noise buffers have been applied if the building is residential); and
- Registered Historic Parks and Gardens.

The following constraints and their buffer distances (where one has been applied) are fixed for different turbine sizes.

- Ancient Woodlands – a 15-metre buffer has been applied to avoid root damage;
- Broadleaved Woodland a 15-metre buffer has been applied to avoid root damage;
- Existing buildings (extent);
- Watercourses – including major, secondary, and minor rivers, canals and lakes; - a 2-metre buffer has been applied to rivers and streams;
- Active mines/quarries; and
- Local Nature Reserves.

The following constraints and their buffer distances (where one has been applied) are likely to change when considering different turbine sizes.

- Major transport infrastructure – topple distance buffers have been applied (tip height +10%);
- Minor transport infrastructure – topple distance buffers (tip height +10%) have been applied;
- Noise buffers – existing dwellings;
- Operational and consented (but not yet constructed) renewables energy development sites (solar PV and wind);
- Ministry of Defence (MoD) Sites; and
- Ministry of Defence (MoD) Low Flying Zones.

It should be noted that, whilst the above issues have been considered in the selection of the Search Areas (SAs), the SAs are not final because:

- The SAs remain subject to further investigation based on information provided in this report (e.g. grid connection or landscape sensitivity) and other considerations through the Local Plan process;
- The SAs are formed using specific technology typologies which, if different from the development proposals, may require the mapping exercise to be rerun; and
- If a private landowner wanted a wind turbine closer to their building than was recommended, and nothing else was adversely affected, then loosening of noise restrictions could be considered.

Additionally, it is important to note that proposals for wind turbines above 2.5MW will change the shape and extent of the SAs, and further work will be needed when considering the proposals, particularly around reapplying the primary constraints listed above.

A higher resolution version of this map is contained in the accompanying document ‘South Gloucestershire RERAS – Maps’.

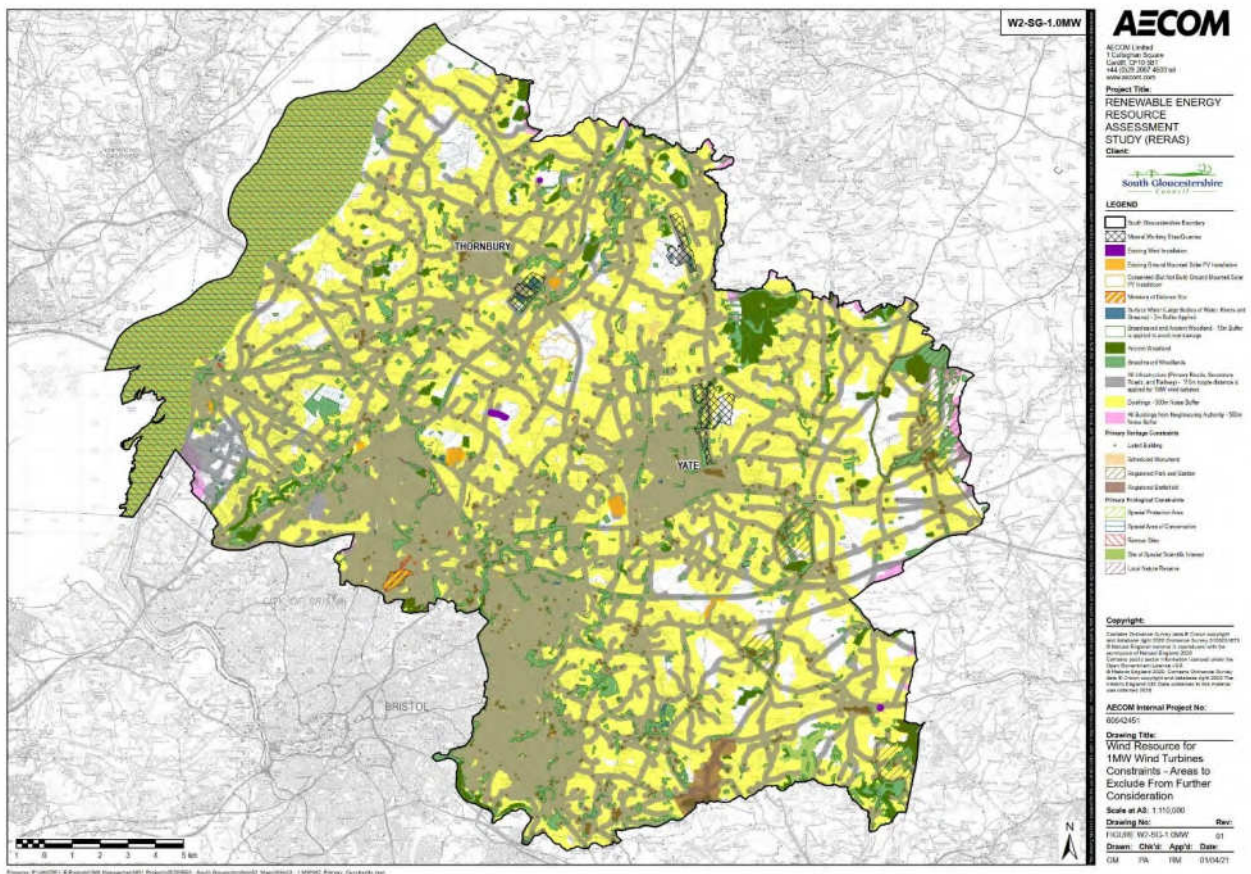

**Figure 34: W2-SG-1.0MW: Wind Resource for 1.0MW Wind Turbines Constraints – Areas to Exclude from Further Consideration Map**

**Policy Recommendation**

**Policy Reference: WF-PR-8 (Refer to Table 39 in Section 17)**

It is recommended that proposals for re-powering of wind farms at end-of-life to an equal or increased capacity will, subject to compliance with the primary constraints listed in Section 4.2.1 (e.g. noise, topple distances), site specific constraints, and other policy considerations should be looked upon favourably.



#### 4.2.2 Identification of Wind Search Areas

As explained above, areas of primary constraints have been applied through GIS to begin to identify potentially suitable locations for the development of wind farms, and these are labelled as wind farm Search Areas. However, these search areas will need to be refined further through the Local Plan process, taking into account other considerations and constraints, as part of developing a strategy for renewable energy development.

##### **Policy Recommendation**

###### **Policy Reference: WF-PR-1 (Refer to Table 39 in Section 17)**

It is recommended that the SAs identified through the RERAS are further refined through the Local Plan process, taking account of other considerations and constraints.

##### **Policy Recommendation**

###### **Policy Reference: WF-PR-2 (Refer to Table 39 in Section 17)**

It is recommended that proposals for wind turbines of the appropriate number and size (to make the most efficient use of the resource/ land) benefit from a presumption in favour of wind development when located within the areas identified for that use through the Local Plan.

Following the application of the primary constraints, the remaining area of potential wind resource<sup>84</sup> informs the calculation of the maximum potential generation capacity. This number then informs the identification of the theoretical maximum renewable energy generation in South Gloucestershire, see Section 15.

Figure 35 illustrates the identified wind Search Areas (SAs) for each of the three wind turbine sizes, the 500kW SAs are coloured orange, the 1.0MW SAs blue striped and the 2.5MW SAs in pink. There were 573, 9 and 8 SAs identified for 500kW, 1.0MW and 2.5MW turbines, respectively. The SAs are referenced based on their corresponding wind turbine size and prioritised based on size (largest), e.g. 1.0MW-LSA-1 is the largest SA suitable for 1.0MW wind turbines installations. It was assumed that one 500kW turbine would be situated on each SA identified as suitable for a 500kW turbine.

##### **Policy Recommendation**

###### **Policy Reference: WF-PR-3 (Refer to Table 39 in Section 17)**

It is recommended that proposals for wind turbines >2.5MW within the areas identified through the Local Plan will benefit from a presumption in favour of wind development, subject to compliance with the primary constraints listed in Section 4.2.1 (e.g. noise, topple distances) and consideration of other site-specific issues and constraints.

##### **Policy Recommendation**

###### **Policy Reference: WF-PR-4 (Refer to Table 39 in Section 17)**

It is recommended that proposals for wind turbines outside of areas identified as suitable for wind development through the Local Plan should be considered positively, providing it can demonstrate that proposals are compliant with relevant policy and site-specific issues and constraints can be mitigated to the satisfaction of the Council.

A higher resolution version of this map is contained in the accompanying document 'South Gloucestershire RERAS – Maps'.

<sup>84</sup>Labelled as "Unconstrained Wind Resource" on W6 maps

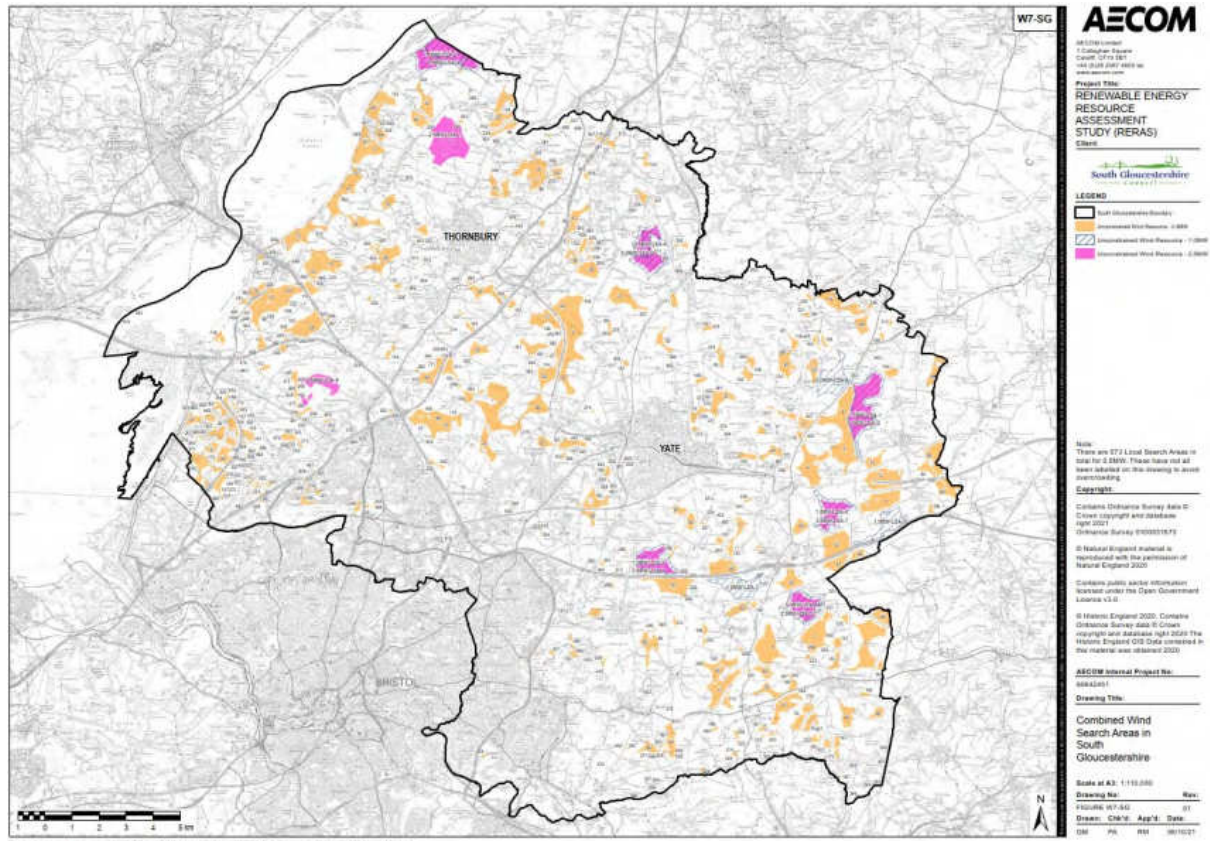

**Figure 35: W7-SG: Combined Wind Search Areas in South Gloucestershire Map**

A total of 43.75km<sup>2</sup>, 10.77 km<sup>2</sup> and 8.13 km<sup>2</sup> of land was identified as being potentially suitable for the installation of a 500kW, 1.0MW and 2.5MW wind turbines respectively. These areas comprise large parts of rural South Gloucestershire, as can be seen in Figure 35.

**Policy Recommendation**

**Policy Reference: WF-PR-9 (Refer to Table 39 in Section 17)**

It is recommended that proposals for wind turbines at the former Oldbury Power Station site will, subject to compliance with noise, topple-distance, site-specific constraints and other policy considerations should be looked upon favourably.

**Table 10: Identified Wind SAs in South Gloucestershire and Theoretical Maximum Potential Wind Resource**

Note	Remaining Available Land Area (km <sup>2</sup> )	Potential Total Installed Capacity (MW)	Potential Total Electricity Generation (GWh)
SAs for 500kW wind turbines in South Gloucestershire	43.75	286.5 <sup>85</sup>	623.60
SAs for 1.0MW wind turbines in South Gloucestershire	10.77	86.13	187.54
SAs for 2.5MW wind turbines in South Gloucestershire	8.13	73.17	159.26
Total		392.49 <sup>86</sup>	854.31

<sup>85</sup> 573 additional small land parcels for 500kW turbines installations have been identified. It is assumed that one 500 kW turbine could be sited on each.

<sup>86</sup> The potential from 1.0MW and 2.5MW search areas cannot be added together as some of the areas overlap. The maximum capacity in this table is taken from 1.0MW search areas plus and additional non-overlapping 2.5MW search areas.

**Policy Recommendation****Policy Reference: WF-PR-5 (Refer to Table 39 in Section 17)**

It is recommended that the SAs identified through the RERAS for 1MW and 2.5MW turbines are further refined and safeguarded through the Local Plan process.

**Policy Recommendation****Policy Reference: WF-PR-7 (Refer to Table 39 in Section 17)**

It is recommended that proposals for wind development within areas identified through the Local Plan for 1 and 2.5MW turbines maximise the potential resource. Where this is not the case, applicants should provide evidence as to why this is not feasible or viable.

The remaining land available and potential installed capacity for each of the 1.0MW and 2.5MW Search Areas are shown in Table 11 and Table 12 respectively.

**Table 11: Individual Identified 1.0MW Wind SAs in South Gloucestershire and Their Theoretical Maximum Potential Installed Capacity**

SA Reference on Maps	SA Area (km <sup>2</sup> )	Potential Total Installed Capacity (MW) <sup>87</sup>
1.0MW-1	1.946	15.57
1.0MW-2	1.709	13.67
1.0MW-3	1.377	11.01
1.0MW-4	1.147	9.18
1.0MW-5	1.119	8.95
1.0MW-6	1.053	8.43
1.0MW-7	0.884	7.07
1.0MW-8	0.815	6.52
1.0MW-9	0.719	5.75

**Table 12: Individual Identified 2.5MW Wind SA's in South Gloucestershire and Their Theoretical Maximum Potential Installed Capacity**

SA Reference on Maps	SA Area (km <sup>2</sup> )	Potential Total Installed Capacity (MW) <sup>87</sup>
2.5MW-1	1.646	14.81
2.5MW-2	1.456	13.10
2.5MW-3	1.355	12.20
2.5MW-4	0.948	8.54
2.5MW-5	0.796	7.16
2.5MW-6	0.767	6.90
2.5MW-7	0.601	5.41
2.5MW-8	0.561	5.05

<sup>87</sup> Potential total installed capacities are calculated using density factors provided in Table 9.

### 4.2.3 Other Constraints for Further Consideration

Effects of some of the other constraints that may impact wind development within the SAs were analysed. These constraints will need to be examined as part of the Local Plan process. The identified SAs on the W7 map have not been constrained utilising the 'other constraints'. Appendix E and Appendix G include further details regarding this analysis.

- Other woodlands (Other than Broadleaved Woodland and Ancient Woodland);
- Area of Outstanding Natural Beauty (AONB);
- Natural England's Impact Risk Zones for Wind Development (IRZs);
- Unlicensed Aerodromes;
- Minerals Safeguarding Areas;
- National Air Traffic Control Services (NATS) Radar Safeguarding Areas;
- Aviation Safeguarded Zone;
- Flood Zones;
- National Trust Inalienable Land;
- Green Belt<sup>88</sup>;
- MoD Safeguarding Zones;
- Consented (but not yet constructed) solar PV and wind developments where their planning permissions may have lapsed; and
- Conservation Areas (Heritage).

A higher resolution version of this map is contained in the accompanying document 'South Gloucestershire RERAS – Maps'.

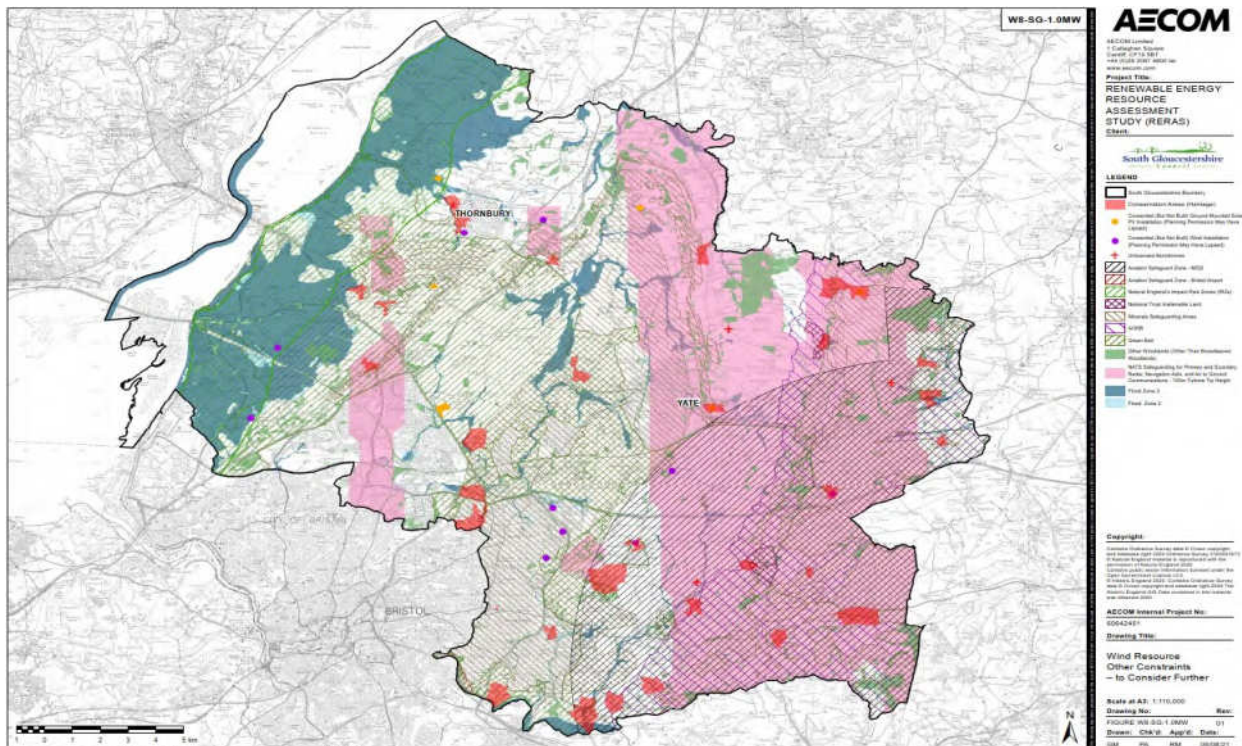

Figure 36: W8-SG-1.0MW: Wind Resource Other Constraints – to Consider Further Map

### 4.3 Proximity to Grid and Grid Capacity

Issues related to grid connection are relevant to both wind and solar energy developments. Therefore, the findings of RERAS regarding this are combined and provided in Section 6.

### 4.4 Landscape Sensitivity Assessment

An additional parameter that can be considered in ranking the Search Areas is the sensitivity of the landscape to new wind/ solar PV development. To facilitate an understanding of this issue, Land Use Consultants (LUC) has conducted a landscape sensitivity assessment for wind and solar energy development, and the results of the assessment are provided in Section 7 of this report.

### 4.5 Further Constraints to Wind Energy Sites

Further constraints to onshore wind development not considered within this RERAS may include (but are not restricted to):

- Practical access to sites required for development;
- Landowner willingness for development to go ahead;
- National planning policies, which are outside of the Council's control;
- Community support; and
- Time to complete planning procedures.

### 4.6 Summary and Potential Opportunities for Future Development

Wind generation has the potential to be a significant source of renewable energy generation in South Gloucestershire, with the identification of:

- 573 SAs for small (500kW) turbines;
- 9 SAs for medium (1.0MW) turbines; and,
- 8 SAs for large (2.5MW) turbines.

Figure 35 highlights that there is a considerable overlap of 1.0MW and 2.5MW SAs, with there being significant opportunities for 500kW turbine installations across the South Gloucestershire area. Table 13 shows details of the SAs and their potential installed capacity and energy generation.

**Table 13: Identified Wind SAs in South Gloucestershire and Theoretical Maximum Potential Wind Resource**

Map Reference	Note	Remaining Available Land Area (km <sup>2</sup> )	Potential Total Installed Capacity (MW)	Potential Total Electricity Generation (GWh)
W6-SG-0.5MW	SAs for 500kW wind turbines in South Gloucestershire	43.75	286.5 <sup>89</sup>	623.60
W6-SG-1.0MW	SAs for 1.0MW wind turbines in South Gloucestershire	10.77	86.13	187.54
W6-SG-2.5MW	SAs for 2.5MW wind turbines in South Gloucestershire	8.13	73.17	159.26
	Total		392.49 <sup>90</sup>	854.31

Additionally, SAs have been further ranked (for information purposes only) using the WPD grid connection analysis and the LUC landscape sensitivity assessment. The WPD grid connection analysis can be used to identify the most favourable locations when considering updates to the grid.

<sup>89</sup> 573 additional small land parcels for 500kW turbines installations have been identified. It is assumed that one 500 kW turbine could be sited on each.

<sup>90</sup> The potential from 1.0MW and 2.5MW search areas cannot be added together as some of the areas overlap. The maximum capacity in this table is taken from 1.0MW search areas plus and additional non-overlapping 2.5MW search areas.

The LUC landscape sensitivity assessment can guide the Council to the locations that will have the least impact on the landscape.

The only other technology addressed in this study with the potential to produce more renewable electricity was solar PV. However, when comparing wind to solar PV, wind turbines require significantly less land take than PV to generate the same amount of electricity.

Due to the benefits of wind developments (typically greater CO<sub>2</sub> saving per square metre) as well as the relatively smaller number of sites (and area) for such development as opposed to solar, consideration should be given to protecting such sites solely for wind development as well as against sterilisation from other forms of nearby development.

Moreover, the effects of other constraints such as AONB and Green Belt would need to be examined as part of the Local Plan process. Therefore, these additional constraints were analysed and included in the study as information to assist the Council in developing its proposed policy approach. Appendix E includes details of these additional constraints and potential capacity of the SAs if the overlapping areas covering these constraints and SAs were removed. The additional maps also cover radar, MoD and aviation safeguarding as well as Conservation Areas (Heritage) to assist developers and councils with any dialogue/consultation that may be required with these organisations regarding wind turbine installations.

In relation to wind energy, potential opportunities for South Gloucestershire could be:

- Investment interest of Energy Services Companies (ESCOs);
- South Gloucestershire involvement with ESCO to secure greater community benefits;
- Wind farms can provide significant revenue streams.

## 5. Solar PV Farms

### 5.1 Introduction

This section provides details of the assessment of the potential for Solar Photovoltaic (PV) Farms within South Gloucestershire. Information on solar PV can be found in Section 1.8.2.

The Department for Business Energy and Industrial Strategy (BEIS) -formerly the Department for Energy and Climate Change (DECC) defines a “stand-alone” installation as a “solar photovoltaic electricity generating facility that is not wired through a building, or if it is wired through a building, the building does not have the ability to use 10% or more of the electricity generated”.

PV solar cells/ panels generate renewable electricity from the direct conversion of solar irradiation. PV is recognised as one of the key technologies in meeting the UK target of net zero greenhouse gas emissions by 2050. Electricity will be increasingly important in supporting net zero delivery, potentially providing around half of the UK’s final energy demand as its use for heat and in transport increases<sup>91</sup>.

In 2019, 28% of renewable installations across the UK installed capacity were solar PV. This figure is expected to increase due to the falling costs of PV modules leading to increasing viability of ground-mounted solar installations<sup>92</sup>. The Contracts for Difference (CfD) scheme is the Government’s main mechanism for supporting new low carbon electricity generation projects. The scheme is being updated to support the UK’s 2050 net zero target delivery whilst simultaneously minimising consumer costs<sup>93</sup>.

This section provides the approach to a high-level assessment of the potential solar resource for ‘stand-alone’ PV farms. It is primarily concerned with identifying opportunities for solar PV development of larger than 5MW.

### 5.2 Mapping

The solar PV farm potential in South Gloucestershire was determined through a series of steps in which the primary constraints associated with such development have been considered. The datasets corresponding to these constraints are overlaid in stages, by applying to GIS mapping, to produce the Search Areas shown in the RERAS. This assessment considers a combination of primary constraints comprising those that exclude certain places from being considered as potentially suitable as areas of search for locating solar PV farms (e.g., international nature conservation designations), as well as those that require further consideration through the Local Plan process. These constraints and the GIS mapping stages at which they were applied was discussed and agreed with South Gloucestershire Council.

Maps have been produced to illustrate, at each stage of the study process, the primary constraints and opportunities.

The flowchart in Figure 37 shows the steps taken and the output maps at each stage of the mapping process. These maps are contained in the accompanying document ‘South Gloucestershire RERAS – Maps’.

For an in-depth, step-by-step explanation of the mapping process, please see Appendix H.

<sup>91</sup> [https://assets.publishing.service.gov.uk/government/uploads/system/uploads/attachment\\_data/file/943714/Modelling-2050-Electricity-System-Analysis.pdf](https://assets.publishing.service.gov.uk/government/uploads/system/uploads/attachment_data/file/943714/Modelling-2050-Electricity-System-Analysis.pdf)

<sup>92</sup> <https://www.gov.uk/government/statistics/regional-renewable-statistics>

<sup>93</sup> [https://assets.publishing.service.gov.uk/government/uploads/system/uploads/attachment\\_data/file/945301/cfd-cm-scheme-update-2020.pdf](https://assets.publishing.service.gov.uk/government/uploads/system/uploads/attachment_data/file/945301/cfd-cm-scheme-update-2020.pdf)

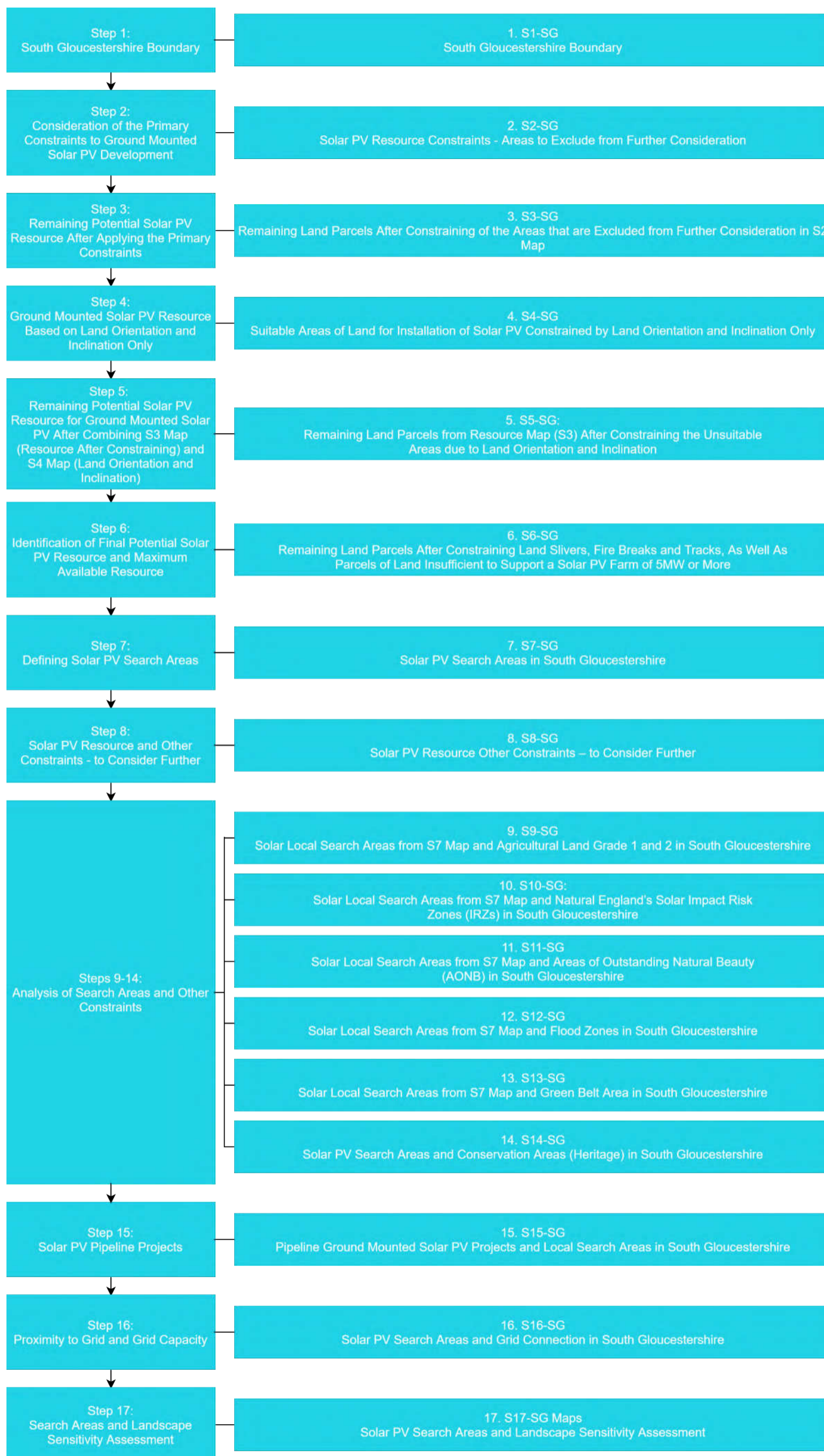

Figure 37: Flow Chart of Solar PV Mapping Process



### 5.2.1 Primary Constraints

The list below illustrates the primary constraints to the development/ deployment of solar PV farms. The reason for mapping these areas of constraint is to remove them from consideration in order to produce initial solar PV farm Search Areas, which can then be refined through the Local Plan process. Items in brackets indicate that no areas of this type are present in South Gloucestershire. Appendix H and Appendix I include further details regarding this analysis.

- Special Protection Areas (SPA);
- Special Areas of Conservation (SAC);
- RAMSAR sites;
- (National Nature Reserves (NNR));
- Sites of Special Scientific Interest (SSSI);
- Scheduled Monuments;
- Listed Buildings;
- Registered Historic Parks and Gardens;
- Ancient Woodlands – a 15-metre buffer has been applied to avoid root damage;
- Broadleaved Woodland, a 15-metre buffer has been applied to avoid root damage;
- Major transport infrastructure;
- Minor transport infrastructure;
- Existing buildings/settlements;
- Watercourses – including major, secondary, and minor rivers, canals, and lakes; - a 2-metre buffer has been applied to rivers and streams;
- Ministry of Defence (MoD) Sites;
- Operational and consented (but not yet constructed) renewables energy development sites (solar PV and wind);
- Active mines/quarries; and
- Local Nature Reserves.

A comprehensive table of the constraints is given in Appendix I.

A higher resolution version of this map is contained in the accompanying document 'South Gloucestershire RERAS – Maps'.

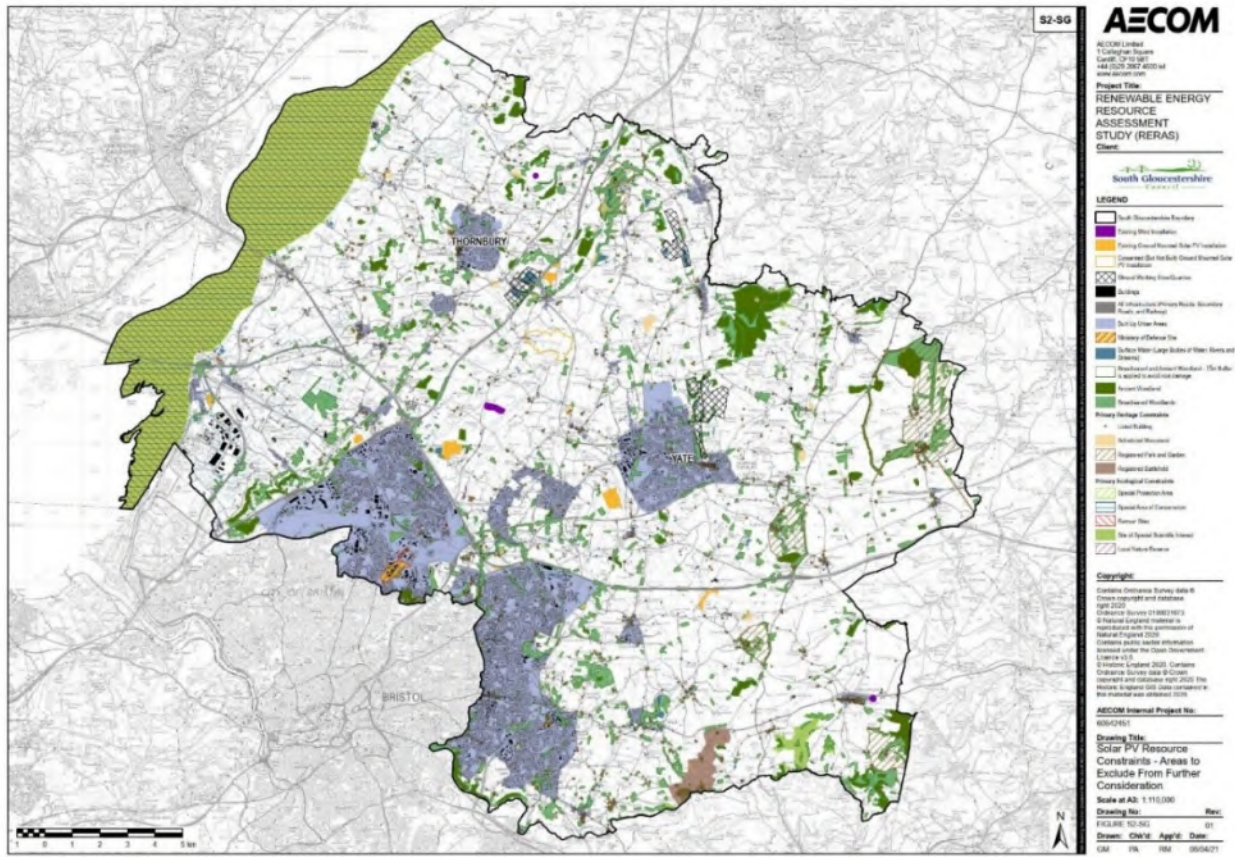

**Policy Recommendation**

**Policy Reference: SF-PR-4 (Refer to Table 40 in Section 17)**

It is recommended that proposals for re-powering of solar PV farms at end-of-life to an equal or increased capacity, subject to compliance with primary constraints, site specific constraints, and other policy considerations should be looked upon favourably.

**5.2.2 Identification of Solar PV Search Areas**

As explained above, areas of constraint have been applied through mapping to begin to identify potentially suitable locations for the development of solar PV farms, and these are labelled as solar PV farm Search Areas. However, these search areas will need to be refined further through the Local Plan process, taking into account other considerations and constraints, as part of developing a strategy for renewable energy development.

**Policy Recommendation**

**Policy Reference: SF-PR-1 (Refer to Table 40 in Section 17)**

It is recommended that the SAs identified through the RERAS are further refined through the Local Plan process, taking account of other considerations and constraints. As part of this a strategy approach which takes account of clustering and the potential need to manage cumulative impact should be considered.

**Policy Recommendation**

**Policy Reference: SF-PR-2 (Refer to Table 40 in Section 17)**

It is recommended that proposals for solar PV farms within the areas identified for that use through the Local Plan benefit from a presumption in favour of solar development.

Following the application of the primary constraints, the remaining area of potential<sup>94</sup> solar PV resource informs the calculation of the maximum potential generation capacity. This number then informs identification of the theoretical maximum renewable energy generation in South Gloucestershire, see Section 15.

As this study is primarily concerned with identifying solar PV development opportunities larger than 5MW, AECOM created a GIS grid layer. On this map, each square is equivalent to the spatial requirement of a 5MW solar farm, and this layer was overlaid onto the remaining area of potential solar PV resource map<sup>95</sup>. Whilst this map was utilised for identifying the nearest transformer to each of the SAs, the squares also provide the reader with a sense of scale of the potential solar PV farms.

**Policy Recommendation**

**Policy Reference: SF-PR-3 (Refer to Table 40 in Section 17)**

It is recommended that proposals for solar development outside of areas identified as suitable for that use through the Local Plan should be considered positively, providing it can demonstrate that proposals are compliant with relevant policy and site-specific issues and constraints can be mitigated to the satisfaction of the Council.

A higher resolution version of this map is contained in the accompanying document ‘South Gloucestershire RERAS – Maps’.

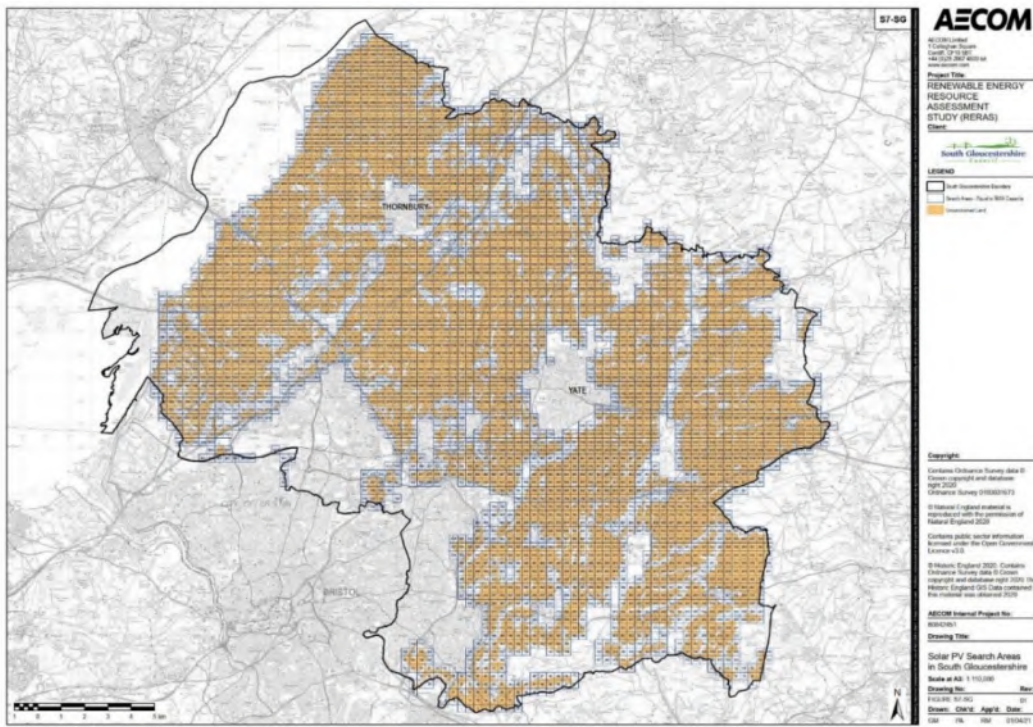

**Figure 39: S7-SG: Solar PV Search Areas in South Gloucestershire Map**

<sup>94</sup>Labelled as “Unconstrained Land” on S6 and S6 maps

<sup>95</sup>Labelled as “Unconstrained Land” on S6 and S7 maps

A total of 268.42km<sup>2</sup> of land was identified as being potentially suitable for the installation of a solar PV farm. This area comprises a large part of rural South Gloucestershire, as can be seen in Figure 39.

It was assumed the land area required for a 5MW fixed-tilt PV array is approximately 30 acres (or 12Ha or 0.12km<sup>2</sup>)<sup>96</sup> and that a solar farm will generate energy at peak for 11% of the time (964 hours) over the course of a year<sup>97</sup>.

**Table 14: Remaining Land Available for Ground Mounted Solar PV Farms at this Stage and its Potential Total Installed Capacity**

Remaining Available Land Area (km <sup>2</sup> )	Potential Total Installed Capacity (MW)	Potential Energy Generated (GWh)
268.42	11,184.2	9,797

### 5.2.3 Other Constraints to Consider Further

Effects of some of the 'other constraints' that may impact ground-mounted solar PV development within the SAs were analysed. These constraints will need to be examined as part of the Local Plan process. The identified SAs on the S7 map have not been constrained utilising the 'other constraints'. Appendix H and Appendix J include further details regarding this analysis.

- Other woodlands (Other than Broadleaved Woodland and Ancient Woodland);
- Area of Outstanding Natural Beauty (AONB);
- Natural England's Impact Risk Zones for Solar Development (IRZs);
- Minerals Safeguarding Areas;
- Flood Zones;
- National Trust Inalienable Land;
- Green Belt<sup>98</sup>;
- Agricultural Land Classification (ALC);
- Consented (but not yet constructed) solar PV and wind developments where their planning permissions may have lapsed; and
- Conservation Areas (Heritage).

A higher resolution version of this map is contained in the accompanying document 'South Gloucestershire RERAS – Maps'.

<sup>96</sup> According to the DECC UK Solar PV Strategy Part 1: 'Roadmap to a Brighter Future', the land area required for a 1MW fixed-tilt PV array is approximately 6acres (or 2.4Ha or 0.024km<sup>2</sup>). See above link

<sup>97</sup> Average of the five previous years' regional standard load factors published by BEIS.

<sup>98</sup> As stated in the NPPF, paragraph 151: 'When located in the Green Belt, elements of many renewable energy projects will comprise inappropriate development. In such cases developers will need to demonstrate very special circumstances if projects are to proceed. Such very special circumstances may include the wider environmental benefits associated with increased production of energy from renewable sources'

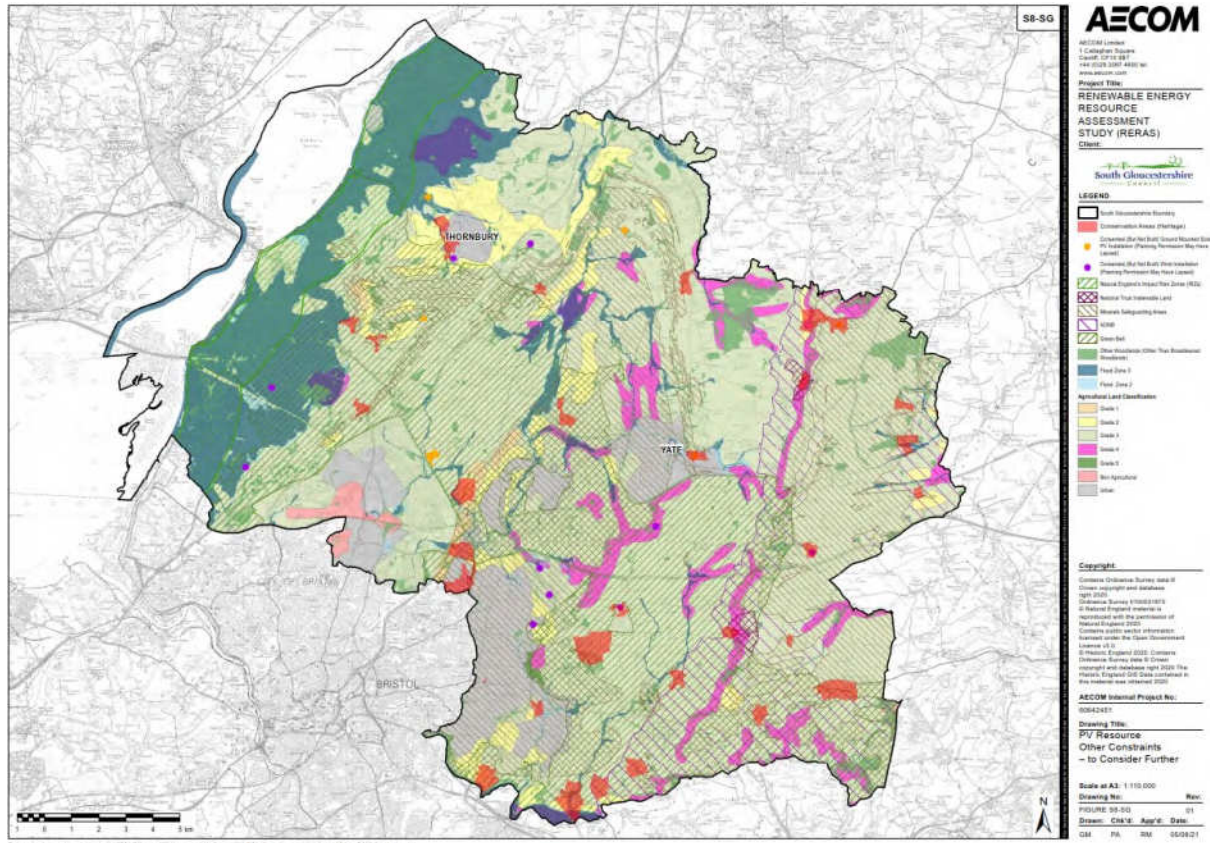

Figure 40: S8-SG: Solar PV Resource Other Constraints – to Consider Further Map

### 5.3 Proximity to Grid and Grid Capacity

Issues related to grid connection are relevant to both wind and solar energy developments. Therefore, the findings of RERAS regarding this are combined and provided in Section 6.

### 5.4 Landscape Sensitivity Assessment

An additional parameter that can be considered in ranking the Search Areas is the sensitivity of the landscape to new wind/ solar PV development. To facilitate an understanding of this issue, LUC has conducted a landscape sensitivity assessment for wind and solar energy development, and the results of the assessment are provided in Section 7 of this report.

### 5.5 Further Constraints to Solar PV Farms

Further constraints to solar PV farm development that are not considered within this RERAS include (but are not necessarily restricted to):

- Practical access to sites required for the development;
- Landowner willingness for development to go ahead;
- National planning policies, which are outside of the Council's control;
- Harnessing community support; and
- Time to complete planning procedures.

## 5.6 Summary and Potential Opportunities for Future Development

Solar PV has the potential to be a significant source of renewable energy generation in South Gloucestershire, with the largest potential of any of the technologies in the study.

Across South Gloucestershire, 268.42km<sup>2</sup> of land was identified as suitable for solar PV development, covering a significant amount of the rural land within South Gloucestershire. Table 15 below shows the potential installed capacity and energy generation from the identified solar SAs in this study.

**Table 15: Potential Installed Capacity and Energy Generation from the Identified Search Areas for Ground Mounted Solar PV Farms**

Map Reference	Total Land Area (km <sup>2</sup> )	Potential Total Installed Capacity (MW)	Potential Energy Generated (GWh)
S6-SG	268.42	11,184.2	9,797

Moreover, the effects of other constraints such as Agricultural Land Classification (ALC) or Green Belt areas that may impact ground-mounted solar PV development within the SAs were considered by spatial mapping the SAs and the constraints on separate maps. A comprehensive list of these additional constraints is provided in Appendix H. As part of the analysis, the impact of a selected number of these constraints on the SAs was assessed by removing the overlapping areas covering these constraints and SAs. Table 16 below includes details of the assessment.

**Table 16: Remaining Area of SAs After Applying Selected Other Constraints for Illustrative Purposes Only**

Map Reference	Other Constraint Shown on the Map	Area of the Final Solar SAs Identified in Step 6 (km <sup>2</sup> )	Potential Installed Capacity of the Final Solar SAs (MW)	Remaining SAs if Area of the Other Constraint Is Removed (km <sup>2</sup> )	Remaining Potential Installed Capacity of the SAs if Area of the Other Constraint Is Removed (MW)
S9-SG	Agricultural Land Grade 1 and 2	268.42	11,184.2	249.07	10,377.9
S10-SG	Natural England's IRZs for Solar	268.42	11,184.2	237.6	9,900.0
S11-SG	AONB	268.42	11,184.2	203.09	8,462.1
S12-SG	Flood Zones	268.42	11,184.2	209.34	8,722.5
S13-SG	Green Belt	268.42	11,184.2	131.17	5,465.4

Moreover, SAs have been further ranked (for information purposes only) using the WPD grid connection analysis results and the LUC landscape sensitivity assessment. The WPD grid connection analysis can be used to identify the most favourable locations when considering the connection to the grid. The LUC landscape sensitivity assessment can be used to guide the Council to the locations that will have the least impact on the landscape.

## 6. Proximity to Grid and Grid Capacity for Wind and Solar PV SAs

Whilst private wire schemes are an option, and some already exist in the UK, onshore wind and solar farms usually have a connection to the grid to export electricity, albeit with increasing curtailments.

Consideration of a viable connection point is an important factor when considering sites for new solar or wind energy development. The cost of a grid connection depends on the distance to the nearest connection point, the works needed to make that connection (there can be a number of complexities such as land ownership issues, whether the dig is hard or soft, etc) and the availability of capacity in the distribution network to take the additional power output. For this study, grid connection is assumed to be a discussion matter for national-level decision-makers and has not been used to constrain wind and solar PV energy generation potential. In addition, as renewable deployment is a national priority, it is assumed that the grid requirement will be met to allow for sufficient additional capacity.

A high-level analysis has been undertaken in consultation with the Distribution Network Operator, Western Power Distribution (WPD). The analysis was undertaken in order to rank the 1.0MW and 2.5MW wind SAs as well as the solar PV SAs in terms of their proximity to a likely grid connection point. Electricity generators <50MWe are exempt from the requirement for an electricity licence<sup>99</sup>. The solar SAs have been divided into 50MW parcels to allow WPD to perform their assessment of the sites. There are proposals for several large scale (circa 50MW) solar PV farms in different planning stages in South Gloucestershire.

WPD reviewed the existing available capacity within the wind SAs and aligned that information to the proximity of existing conductors/cables, and any other accepted or offered connections that may also be seeking capacity. The Search Areas were ranked based on the high-level analysis undertaken in consultation with WPD. The Search Areas are ranked from low priority (coloured red in the maps) to high priority (coloured blue in the maps), with high priority being most favourable for a new connection to the grid as shows in Figure 41.

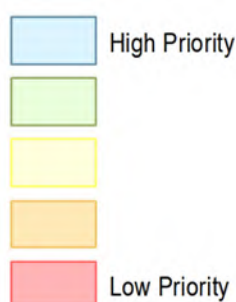

**Figure 41: SAs Proximity to Grid and Grid Capacity Ranking Key (Refer to W16 and S16 Maps in the Accompanying Document ‘South Gloucestershire RERAS – Maps’)**

This ranking has only been taken as a single snapshot based on the latest information. It does not account for any future reinforcement that may be triggered by other new connections or condition-based replacement. Increases or decreases in future demand may also affect capacity and have not been considered within this study. Sites over 1MW may be required to go through the Statement of Works process to confirm acceptance of the connection on the transmission network.

Network access may be accelerated or achieved with reduced costs by progressing an alternative connection, which allows export to be limited at times of high export from other users.

Higher resolution versions of these maps are contained in the accompanying document ‘South Gloucestershire RERAS – Maps’.

<sup>99</sup> Class A: Small generators – Generates lower than 50 megawatts with a declared net capacity of up to 100 megawatts. <https://www.legislation.gov.uk/uksi/2001/3270/schedule/2/made>

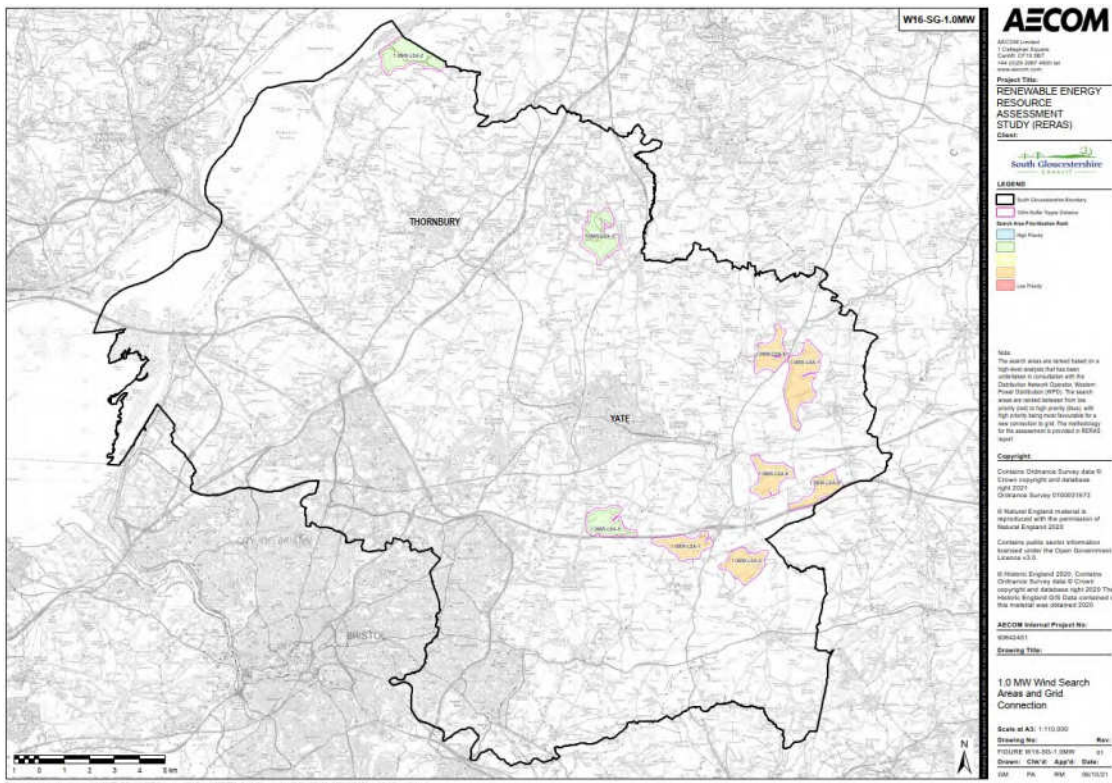

Figure 42: W16-SG-1.0MW: 1.0MW Wind Search Areas and Grid Connection in South Gloucestershire Map

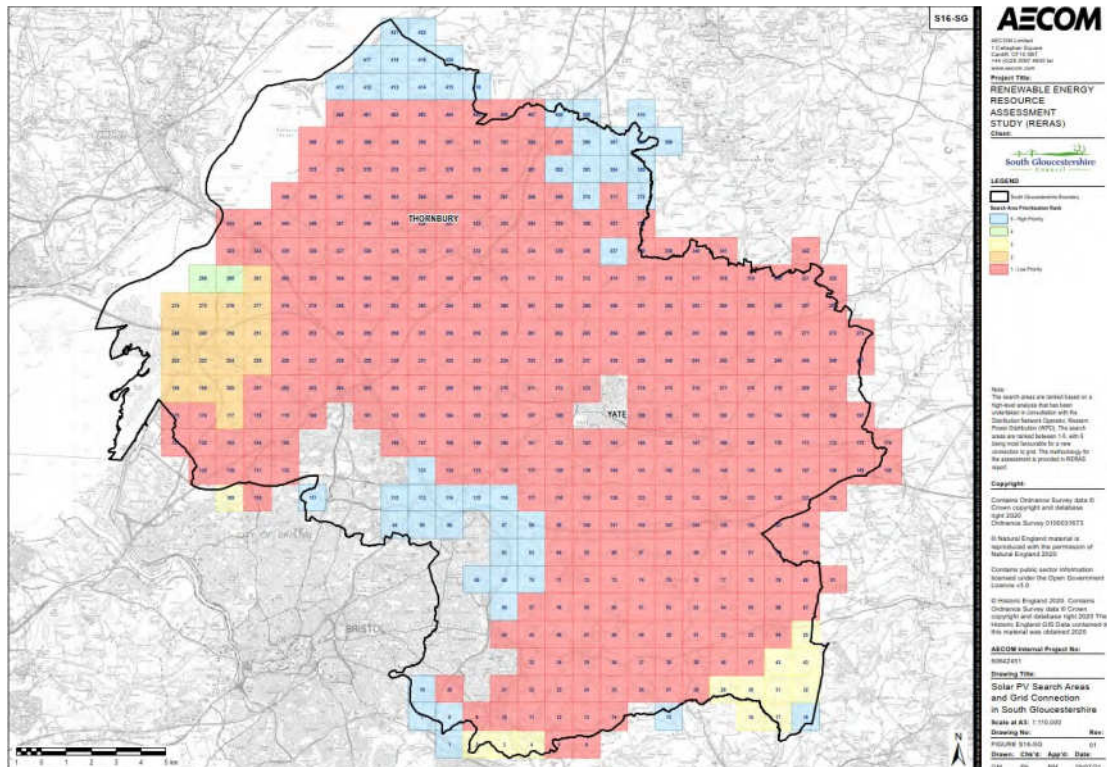

Figure 43: S16-SG: 50MW Solar PV Search Areas and Grid Connection in South Gloucestershire Map



## 7. Wind and Solar PV Search Areas and Landscape Sensitivity

### Assessment

An additional parameter that can be considered in ranking the Search Areas is Landscape Character Areas and the sensitivity of these landscapes to new wind farm and solar PV farm developments. A flowchart presenting the steps taken in completing mapping the results of a landscape sensitivity for both wind farms and solar PV farms is shown in Figure 44 and Figure 45 respectively.



**Figure 44 Steps Taken in Landscape sensitivity Study for Wind Farm Search Areas**

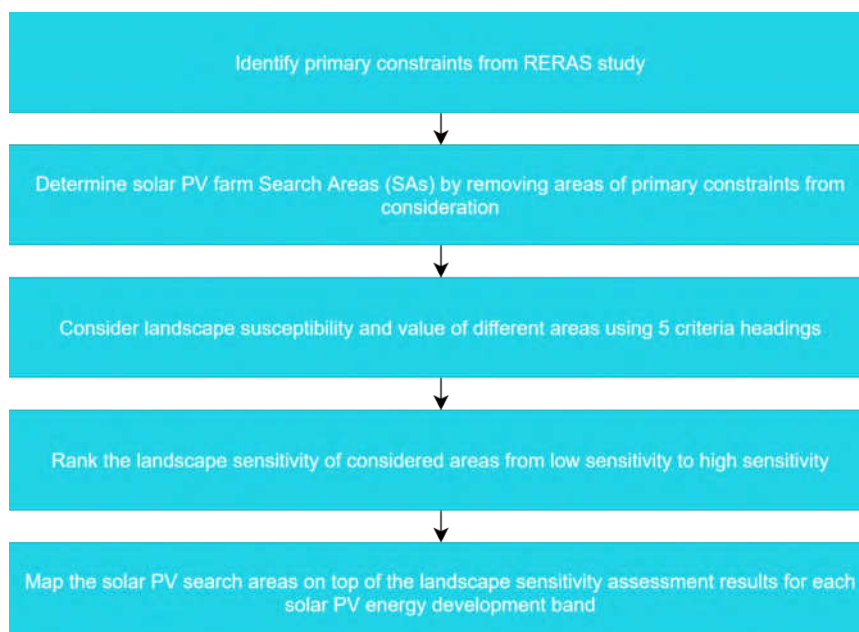

**Figure 45 Steps Taken in Landscape Sensitivity Study for Solar PV Farm Search Areas**

Land Use Consultants (LUC) has conducted a landscape sensitivity assessment for wind and solar PV energy development as part of this RERAS. Results of the assessment provide an initial indication of the relative landscape sensitivity of different areas within South Gloucestershire to accommodate wind farm and solar PV farm energy developments. The findings of the study, combined with the identified Search Areas (SAs), are presented in this section of the report. The landscape sensitivity assessment considers the landscape susceptibility<sup>100</sup> and landscape value<sup>101</sup> using 5 criteria headings:

- Landform and scale (including sense of openness / enclosure);
- Landcover (including field and settlement patterns);
- Historic landscape character;
- Visual character (including skylines); and
- Perceptual and scenic qualities.

Once the above criteria were assessed individually, the results were combined to produce an overall sensitivity level, as shown in Table 17.

**Table 17: The Five-Point Scale Landscape Sensitivity Scale**

Sensitivity Level	Definition
<b>High (H)</b>	Key characteristics and qualities of the landscape are highly vulnerable to change from wind and solar energy development. Such development is likely to result in a significant change in character.
<b>Moderate - High (M-H)</b>	Key characteristics and qualities of the landscape are vulnerable to change from wind and solar energy development. There may be some limited opportunity to accommodate wind turbines/ solar panels without significantly changing landscape character. Great care would be needed in siting and design.
<b>Moderate (M)</b>	Some of the key characteristics and qualities of the landscape are vulnerable to change. Although the landscape may have some ability to absorb wind and solar energy development, it is likely to cause a degree of change in character. Care would be needed in siting and design.
<b>Low - Moderate (L-M)</b>	Fewer of the key characteristics and qualities of the landscape are vulnerable to change. The landscape is likely to be able to accommodate wind and solar energy development with limited change in character. Care is still needed when siting and designing to avoid adversely affecting key characteristics.
<b>Low (L)</b>	Key characteristics and qualities of the landscape are robust in that they can withstand change from the introduction of wind turbines and solar panels. The landscape is likely to be able to accommodate wind and solar energy development without a significant change in character. Care is still needed when siting and designing these developments to ensure best fit with the landscape.

Additionally, the assessment considers the suitability of different turbine heights (to blade tip), based on bandings that reflect those most likely to be put forward by developers (now and in the future). These are set out in Table 18 below.

<sup>100</sup> How vulnerable the landscape is to change from the type being assessed, in this case solar PV and wind energy developments

<sup>101</sup> Consensus about importance, which can be recognised through designation as well as through descriptions within the 2014 Landscape Character Assessment

**Table 18: Wind Turbine Development Sizes Considered in the Landscape Sensitivity Assessment**

Wind Energy Development Banding	Turbine Height (to blade tip)
Band A	18 – 25m
Band B	26 – 60m
Band C	61 – 100m
Band D	101 – 120m
Band E	121 – 150m

The assessment also judges the suitability of different scales of solar PV developments based on bandings that reflect those that are most likely to be put forward by developers. The sizes<sup>102</sup> used for the assessment are set out in Table 19<sup>103</sup>.

**Table 19: Solar PV Farm Development Sizes Considered in the Landscape Sensitivity Assessment**

Solar PV Development Banding	Area
Band A	≤5ha
Band B	6ha – 10ha
Band C	11ha – 15ha
Band D	16ha – 30ha
Band E	31ha – 60ha

The complete assessment methodology and results of a landscape sensitivity assessment is included in the accompanying document 'Landscape Sensitivity Assessment Solar PV and Wind Energy Development - Prepared by LUC – 2021'.

W17 and S17 maps show the landscape sensitivity assessment results overlaid on the identified wind farm search and solar PV farm Search Areas respectively. The figures rank the areas considered for the landscape sensitivity study in line with the sensitivity levels shown in Table 17 and provide guidance on the potential effects of different scale wind development on the landscape. Higher resolution versions of these maps including 500kW, 1.0MW and 2.5MW turbine wind SAs and for bands A to E for solar PV SAs are contained in the accompanying document 'South Gloucestershire RERAS – Maps'. Table 20 and Table 21 below present the results of the landscape sensitivity assessment for 1.0MW and 2.5MW wind SAs.

**Table 20: Individual Identified 1.0MW Wind SA's in South Gloucestershire and Their Landscape Sensitivity Levels**

SA Reference on Maps	Sensitivity Level
1.0MW-1	High
1.0MW-2	High
1.0MW-3	Moderate - High
1.0MW-4	High
1.0MW-5	High
1.0MW-6	High
1.0MW-7	High
1.0MW-8	High
1.0MW-9	High

<sup>102</sup> The sizes of solar PV developments indicate the areas taken up by solar PV panels only.

<sup>103</sup> Proposed solar PV developments larger than 60ha have not been considered in the LUC landscape sensitivity assessment. LUC has confirmed that landscape sensitivity to these very large schemes would be categorised as "high" sensitivity regardless of location, requiring developers to pay particular attention to this issue in their specific applications.

**Table 21: Individual Identified 2.5MW Wind SA's in South Gloucestershire and Their Landscape Sensitivity Levels**

SA Reference on Maps	Sensitivity Level
2.5MW-1	High
2.5MW-2	High
2.5MW-3	High
2.5MW-4	High
2.5MW-5	High
2.5MW-6	High
2.5MW-7	High
2.5MW-8	Moderate - High

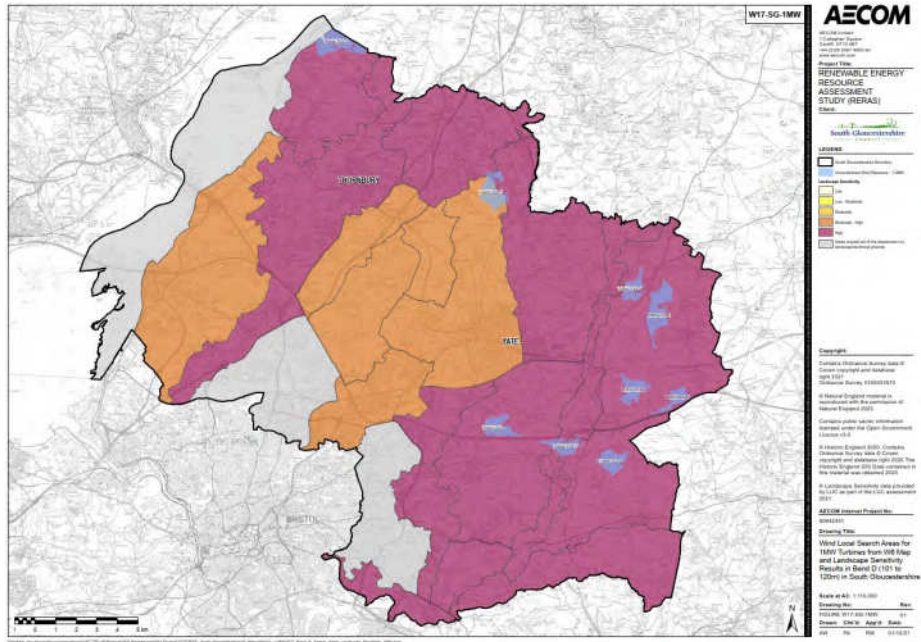

**Figure 46: W17-SG-1MW: Wind Local Search Areas for 1 MW Wind Turbines from W6 map and Landscape Sensitivity Results in Band D (101 to 120) in South Gloucestershire Map**

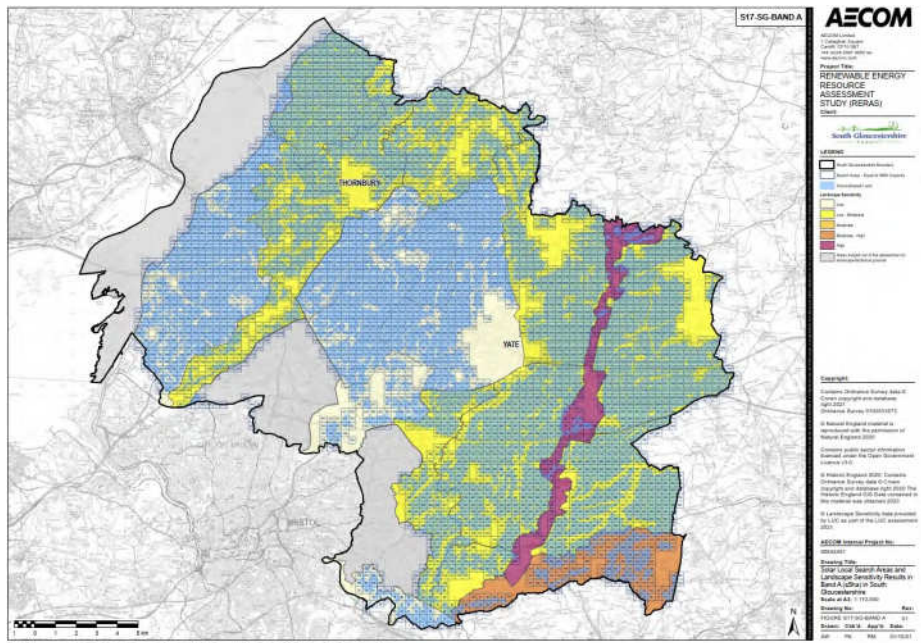

**Figure 47: S17-SG-Band A: Solar Local Search Areas from S6 Map and Landscape Sensitivity Results in Band A (≤5ha) in South Gloucestershire Map**

## 8. Biomass Energy Resource

### 8.1 Introduction

The focus of this section of the study is on establishing the potential biomass resource defined as either:

- Energy crops (e.g. miscanthus, short-rotation coppice, etc.); or,
- Wood fuel resource.

Unlike wind farms, biomass can be utilised to generate electricity and heat and domestic hot water (DHW). The use of energy crops, forestry residues and recycled wood waste for energy generation can have a number of advantages:

- Provide opportunities for agricultural diversification;
- Encourage increased management of woodland;
- Can have positive effects on biodiversity;
- Remove biodegradable elements from the waste stream; and
- Potential for CO<sub>2</sub> savings.

In relation to biomass, the Biomass in a Low Carbon Economy<sup>104</sup> report by the Climate Change Committee (CCC) states:

---

*“Sustainably harvested biomass can play a significant role in meeting long-term climate targets, provided it is prioritised for the most valuable end-uses.”*

---

The report also confirms a significant potential to increase domestic production of sustainable biomass to meet between the equivalent of 5% and 10% of energy demand from UK sources by 2050. More information regarding biomass technology can be found in Section 1.8.6.

There are currently two large-scale dedicated biomass installations in South Gloucestershire. The first is an 8.3MW generator at Power Electrics Generators Limited, Warmley; and the other is a 0.96MW generator at Tesco Stores Ltd, Avonmouth.

A detailed breakdown of the methodology for determining biomass resources can be found in Appendix K.

### 8.2 Energy Crops

#### 8.2.1 Mapping

The potential energy crop resource in South Gloucestershire was determined by, utilising GIS maps, overlaying potential constraints onto the areas identified as having potential for growing such crops. The constraints were identified in consultation with South Gloucestershire Council and are provided in detail in Section 8.2.1.1. In order to avoid competition between land uses (i.e. food crops, livestock grazing, energy crops, etc), Agricultural Land Classification (ALC) land grades 1, 2 and 3 are constrained out and not considered further. Therefore, this study assumed that energy crops could only be grown on agricultural land of Grade 4<sup>105,106</sup> which is not constrained by environmental or

---

<sup>104</sup> <https://www.theccc.org.uk/wp-content/uploads/2018/11/Biomass-in-a-low-carbon-economy-CCC-2018.pdf>

<sup>105</sup> Poor quality agricultural land. Land with severe limitations which significantly restrict the range of crops and/or level of yields. It is mainly suited to grass with occasional arable crops (e.g. cereals and forage crops) the yields of which are variable. In moist climates, yields of grass may be moderate to high but there may be difficulties in utilisation. The grade also includes very droughty arable land.

<sup>106</sup>The Bioeconomy Consultants (2012), Domestic Energy Crops; Potential and Constraints Review, A report for DECC, URN: 12D/081; [https://assets.publishing.service.gov.uk/government/uploads/system/uploads/attachment\\_data/file/48342/5138-domestic-energy-crops-potential-and-constraints-r.PDF](https://assets.publishing.service.gov.uk/government/uploads/system/uploads/attachment_data/file/48342/5138-domestic-energy-crops-potential-and-constraints-r.PDF)

historical protected areas. Maps have been produced to illustrate each stage of the process of identifying primary constraints and also maps that identify the extent of the area of land with potential opportunities.

The flowchart shown in Figure 48 shows the process steps and the output maps at each stage of the mapping. These maps are contained in the accompanying document 'South Gloucestershire RERAS – Maps'.

For an in-depth, step-by-step explanation of the mapping process, please see Appendix K.

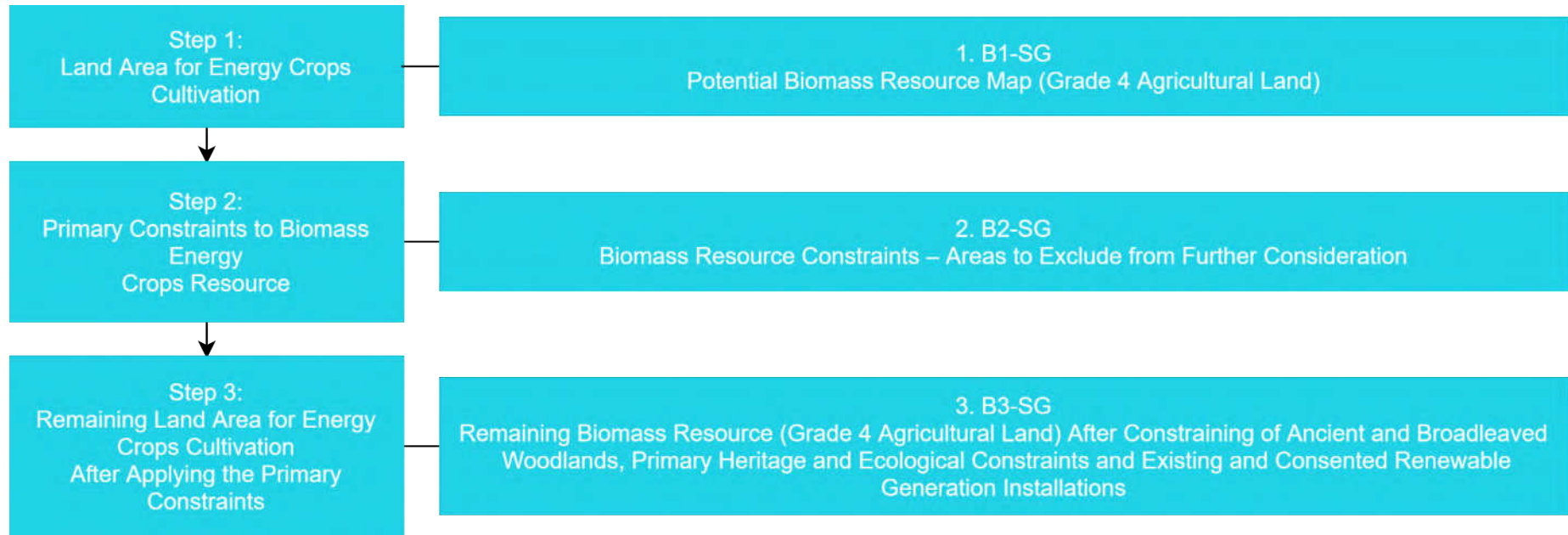
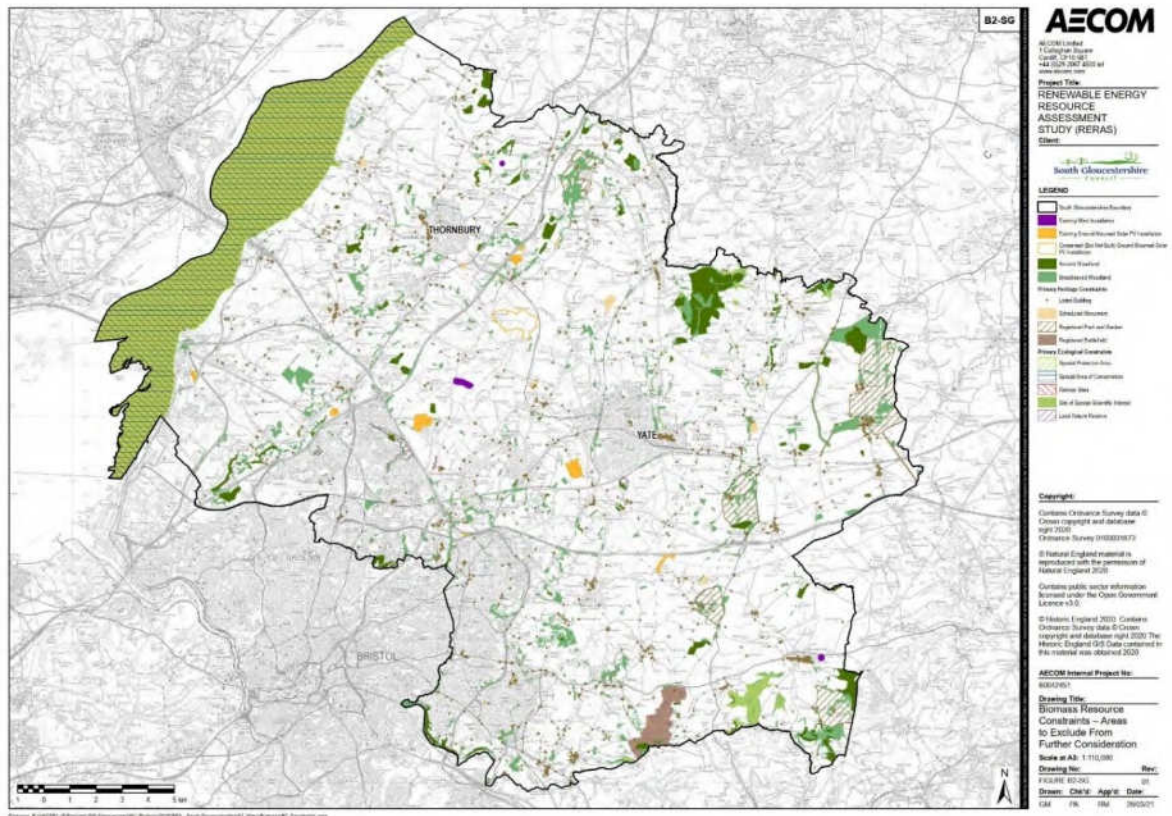

Figure 48: Flowchart of Energy Crop Mapping Process

### 8.2.1.1 Primary Constraints

- Areas of broadleaved woodland;
- Areas of environmental protection (including ancient woodlands);
- Areas of historical and cultural importance; and
- Operational and consented (but not yet constructed) renewables energy development sites (solar PV and wind).

B2 map illustrates these primary constraints that are associated with restrictions to harvesting energy crops. A comprehensive table of the constraints is provided in Appendix L. A higher resolution version of this map is contained in the accompanying document ‘South Gloucestershire RERAS – Maps’.



**Figure 49: B2-SG: Biomass Resource Primary Constraints – Areas to Exclude from Further Consideration Map**

### 8.2.1.2 Identification of Biomass Resource

The remaining available land for energy crop cultivation after removing the constrained areas is shown below in Figure 50, showing a theoretical maximum area of land that could be planted with energy crops as 29.03km<sup>2</sup>.



**Policy Recommendation**

**Policy Reference: BM-PR-1 (Refer to Table 43 in Section 17)**

It is recommended that proposals utilising biomass are looked upon favourably where:

- a. a whole life carbon benefit can be evidenced; and
- b. the development should be located away from urban areas (and preferably in areas off the gas grid).

A higher resolution version of this map is contained in the accompanying document ‘South Gloucestershire RERAS – Maps’.

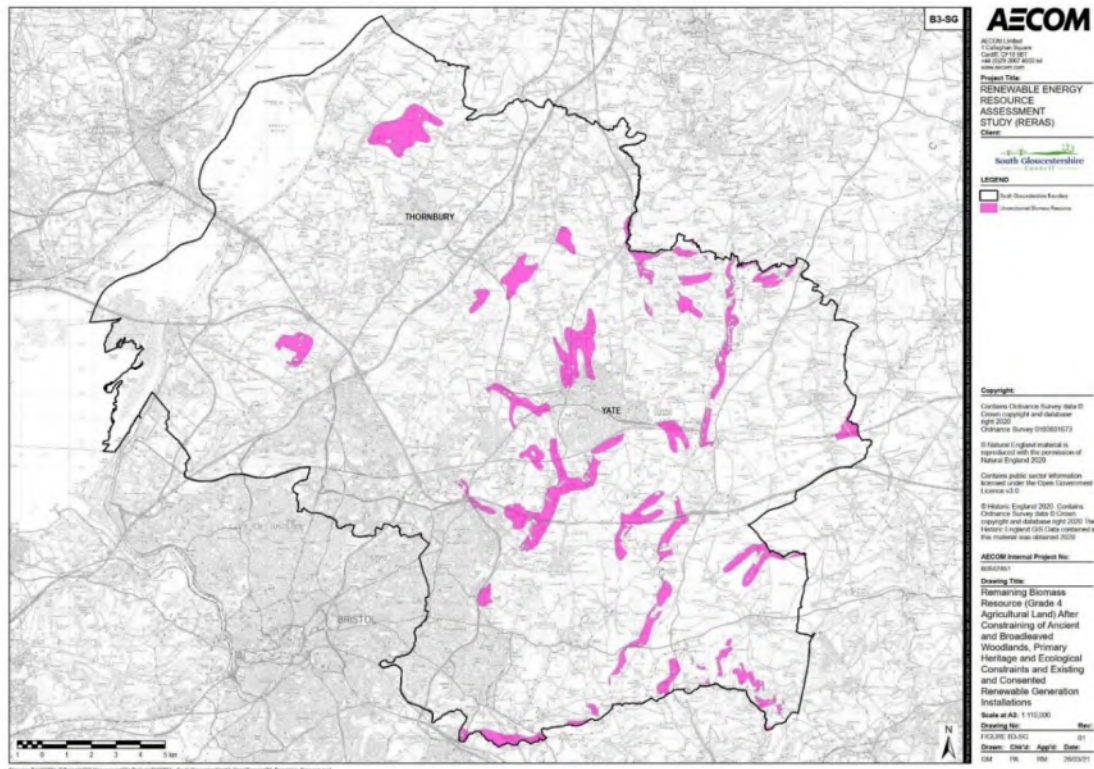

**Figure 50: B3-SG: Remaining Biomass Resource (Grade 4 Agricultural Land) After Constraining of Ancient and Broadleaved Woodlands, Primary Heritage and Ecological Constraints and Existing and Consented Renewable Generation Installations Map**

Competition with other crops, existing areas of energy crop cultivation, livestock grazing, solar PV farms, and unsuitable topography provide limitations on where energy crops can be planted



**Installed Power and Heat Generation Capacity**

Forest Research<sup>107</sup> gives a figure of 7 to 12 oven-dry tonnes/ha/annum yield for short rotation coppice and 12 to 14 oven-dry tonnes (odt)/ha/annum yield for miscanthus. However, in reality, the actual yield will vary within a range, depending on a number of factors such as land grade, crop species, soil types, how many years a particular crop has been established at a site, and so on. Therefore, an

<sup>107</sup> <https://www.forestresearch.gov.uk/tools-and-resources/biomass-energy-resources/fuel/energy-crops/>

average figure of 11 odt per hectare for energy crop yield was assumed in potential installed capacity calculations.

The amount of energy that could potentially be produced from biomass will depend on whether the fuel is burnt in boilers that only generate heat or combusted in Combined Heat and Power units (where the heat is used).

For the purposes of this assessment, it was assumed that the energy crop resource is used to fuel a biomass CHP system to produce electricity and heat<sup>108</sup>. A biomass CHP system can be used to supply small off-grid heat networks, or it could be combined with a small green hydrogen demonstrator where the electricity is to be used to generate hydrogen for transport fuel and/or for use in an industrial setting. Carbon capture, utilisation, and storage (CCUS) may need to be considered for such a hydrogen-related project.

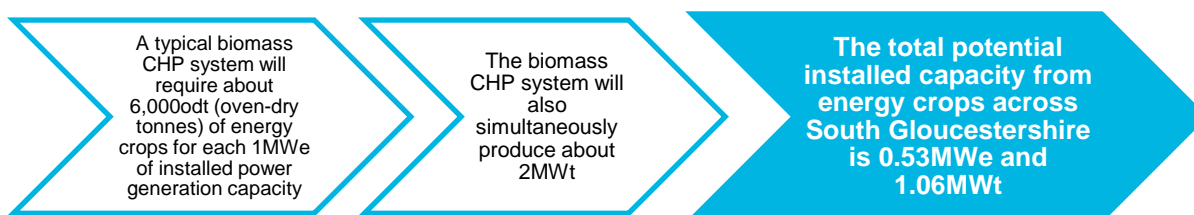

Table 22 below confirms the maximum potential energy crop resource in South Gloucestershire.

**Table 22: Total Potential Energy Crop Resource in South Gloucestershire**  
Energy Crop Resource

Total Available Area (km <sup>2</sup> )	29.03
Usable Area (km <sup>2</sup> )	2.90
Yield (odt per km <sup>2</sup> )	1,100
Yield (odt)	3,193
Required Yield per MWt	6000
<b>Potential Installed Capacity (MWe)</b>	<b>0.53</b>
Heat to Power Ratio	2:1
<b>Potential Installed Capacity (MWt)</b>	<b>1.06</b>

There is a potential installed capacity for energy crops across South Gloucestershire of 0.53MWe and 1.06MWt.

For comparison, the energy generation potential is equal to supplying energy to 46 typical primary schools annually<sup>109</sup>

### 8.3 Wood Fuel

Wood fuel can be harvested from the small round wood stems, tips and branches of felled timber trees and thinning and poor-quality round wood<sup>110</sup>.

For the purposes of this assessment, it was assumed that the energy resource from wood fuel is utilised for SH or DHW or both (i.e. a biomass boiler<sup>111</sup>). For the detailed calculation of the wood fuel resource, please see Appendix K. Table 23 below confirms the maximum potential wood fuel biomass resource in South Gloucestershire. It has been assumed that a biomass boiler may be used to displace coal or oil without necessitating structural, fabric and services changes in buildings, this could be relevant to the buildings in off gas areas in South Gloucestershire.

<sup>108</sup> This is an average figure to cover a range of different technology types, and sizes, with different efficiencies. For example, a smaller scale facility (about 2MWe) using a steam turbine with an efficiency of about 20%, might require up to 8,000 oven dry tonnes/annum. However, a larger facility (5-10MWe), using gasification, with an efficiency of up to 30%, might require about 5,000 oven dry tonnes per annum.

<sup>109</sup> DEC database is used to calculate average annual heat demand in a typical primary school.

<sup>110</sup> National forest is all wood land within the National Forestry Inventory. i.e. All woodland 0.5 hectares and over <https://www.forestresearch.gov.uk/tools-and-resources/national-forest-inventory/about-the-nfi/>

<sup>111</sup> Assuming a boiler efficiency of 80% and a capacity factor of 0.3

**Table 23: Total Potential Energy Resource from Wood Fuel in South Gloucestershire**

<b>Wood Fuel Resource</b>	
Available Area (km <sup>2</sup> )	38.97
Yield (odt per km <sup>2</sup> )	200
Yield (odt)	7,794
Required Yield per MWt	660
<b>Potential Installed Capacity (MWt)</b>	<b>11.8</b>

112

There is a maximum potential installed capacity from Wood Fuel across South Gloucestershire of 11.8MWt, equivalent to supplying energy to 168 typical primary schools annually.<sup>112</sup>

## 8.4 Further Constraints to Biomass Energy Resource

Where areas of land have been indicated as having potential for the growing of energy crops, further detailed studies are required prior to action. Furthermore, market demand is likely to play a vital role in what type of crop is grown, the location and quantity.

Even where there is a local demand for a biomass supply, constraints (not considered within this RERAS) can persist, including the proximity of supply to the plant and practical access to sites required to prepare and deliver fuel.

Further constraints to biomass that are not considered within this RERAS include (but are not necessarily restricted to:

- Landowner willingness;
- National planning policies, which is outside of the Council's control; and
- The time involved in the planning process.

Biomass is most usually utilised in CHP for industrial purposes (typically situated away from residential development) or for heating non-domestic buildings, particularly in non-urban off-gas areas where there are less likely to be Air Quality issues and sufficient room for fuel storage and access for delivery vehicles.

## 8.5 Summary and Potential Opportunities for Future Development

The potential available biomass resource within South Gloucestershire amounts to 0.53MWe and 12.86MWt which equates to 45.11GWht annually. This resource can be used to meet part of the heating demand in South Gloucestershire via renewables, including for use in individual boilers, via district heating networks or incorporated in a fuel electricity plant or CHP plant. It should be noted that the projected biomass use in South Gloucestershire (in Section 14 of this report) is less than the resource identified above. The amount of generation set out in future sections relates to the 2030 projections and aligns with projected demand (including the assumption that all biomass is sourced locally).

Due to the finite supply of biomass, it is essential to ensure that the resource is used to its biggest advantage. A recent report from the Climate Change Committee<sup>113</sup> (CCC) states that biomass should only be used to sequester atmospheric carbon whilst simultaneously providing useful energy; this could include future opportunities for bioenergy with carbon capture and storage, which can provide a useful method for offsetting residual greenhouse gas emissions. Biomass should also only be considered in situations where there are few alternatives.

<sup>112</sup> DEC database is used to calculate average annual heat demand in a typical primary school.

<sup>113</sup> Climate Change Committee, 'Biomass in a Low-Carbon Economy, 2018'; <https://www.theccc.org.uk/wp-content/uploads/2018/11/Biomass-in-a-low-carbon-economy-CCC-2018.pdf>

Alongside concerns relating to the finite supply of biomass resource, there are also health concerns associated with the emissions released as part of the process of burning biomass; for more information on this, see Section 1.8.6.2.

The above concerns should not deter South Gloucestershire Council from maximising the use of the available biomass resource; however, consideration must be taken to ensure the most appropriate way of exploiting this resource is determined. Because of the flexibility of biomass fuel, it is suggested that a bespoke, independent and thorough investigation is conducted into any proposals received in respect of biomass projects to ensure the environmental benefit is secured.

Given the cost of CCUS projects, it may be that such projects are limited in the South Gloucestershire area. However, other projects potentially involving industrial manufacture/process, green hydrogen demonstration and production of biofuels may well be environmentally beneficial, particularly in off-gas grid areas where coal or oil is being displaced and where the biomass source is local and from sustainably managed sources.

In relation to biomass energy generation, potential opportunities for South Gloucestershire Council are:

- Investment interest of Energy Services Companies (ESCOs) may be secured through the identification of appropriate sites and heat demand; and
- Biomass fed renewable installations can provide significant revenue streams to the Council, including from the Renewable Heat Incentive.

## 9. Energy from Waste

### 9.1 Introduction

The Waste Management Plan for England<sup>114</sup> sets out the Government's ambitions to work towards a more sustainable and efficient approach to resource use and waste management. The plan states that all waste management plans must include measures so that, by 2035:

- Re-use and the recycling of municipal waste are increased to a minimum of 65% by weight.
- The amount of municipal waste landfilled is reduced by 10% or less of the total amount of municipal waste generated (by weight).

The West of England Joint Waste Core Strategy<sup>115</sup> (JWCS) sets out the strategic spatial planning policy to provide waste management infrastructure across the planning area. The plan aims to reduce waste taken to the landfill by minimising waste production, increasing recycling and composting, then recovering further value from any remaining waste.

The JWCS highlights that, although material recovery takes priority, energy recovery has a beneficial role to play in both sustainable waste management and as a low carbon energy source from an Energy from Waste (EfW) plant.

The South Gloucestershire Resource and Waste Strategy<sup>116</sup> includes local recycling targets for South Gloucestershire; these are as follows:

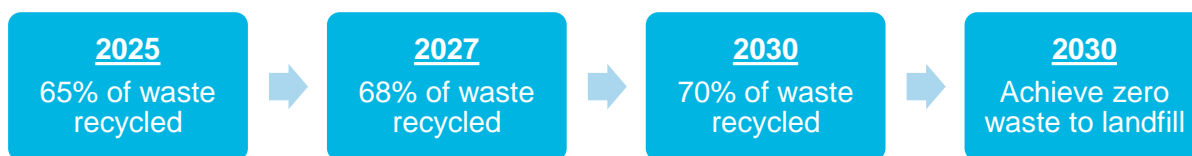

Part of the pathway to achieving these targets includes using Energy Recovery Facilities (ERFs) for non-recyclable waste. The West of England Partnership (South Gloucestershire, North Somerset, Bath and North East Somerset and Bristol City) uses two ERFs to incinerate waste and produce energy for the National Grid.

This section determines the amount of potential electricity and heat generation available from the following waste streams in 2030:

<b>Municipal Solid Waste (MSW)</b>	<ul style="list-style-type: none"> <li>• The 2030 MSW figure was determined by the council's waste prediction model and aligned with the 70% recycling rate target.</li> <li>• It was assumed that the MSW would be used as fuel in a Combined Heat and Power (CHP) facility to produce energy and heat.</li> </ul>
<b>Commercial and Industrial Waste (C&amp;I)</b>	<ul style="list-style-type: none"> <li>• The 2030 C&amp;I waste figure was determined using the 2019 figure from the Waste Data Interrogator (WDI), the "Sustainability Turn" scenario of the DEFRA "Scenario-Building for Future Waste Policy" report and aligned with the 70% recycling rate target.</li> <li>• It was assumed that the C&amp;I would be utilised as a fuel in a Combined Heat and Power (CHP) facility to produce energy and heat.</li> </ul>

<sup>114</sup> Waste Management Plan for England, DEFRA, 2021; [https://assets.publishing.service.gov.uk/government/uploads/system/uploads/attachment\\_data/file/955897/waste-management-plan-for-england-2021.pdf](https://assets.publishing.service.gov.uk/government/uploads/system/uploads/attachment_data/file/955897/waste-management-plan-for-england-2021.pdf)

<sup>115</sup> West of England Joint Waste Core Strategy, WEP, March 2011; <https://www.westofengland.org/waste-planning/adopted-joint-waste-core-strategy>

<sup>116</sup> South Gloucestershire Resource and Waste Strategy: 2020 and Beyond, South Gloucestershire Council, 2020, <https://beta.southglos.gov.uk/wp-content/uploads/1654-Resource-and-Waste-Strategy-2020-and-beyond-v1.0.pdf>

<b>Food Waste</b>	<ul style="list-style-type: none"><li>• The 2030 food waste figure was determined by using the 2019 DEFRA value, assuming that the waste breakdown will remain constant and will increase at the same rate as the MSW between 2019 and 2030.</li><li>• Food waste can be anaerobically digested to produce a suitable gas for combustion and, if the plant is suitably enabled, generate both electricity and heat.</li></ul>
<b>Agricultural Waste - Animal Manure</b>	<ul style="list-style-type: none"><li>• The 2030 animal manure figure was determined using the assumption that the farming mix will not change significantly in South Gloucestershire, and therefore the latest livestock statistics can be used.</li><li>• Animal manure can be treated by anaerobic digestion and utilised in a CHP plant to generate both electricity and heat.</li></ul>
<b>Agricultural Waste - Poultry Litter</b>	<ul style="list-style-type: none"><li>• The 2030 poultry litter figure was determined using the assumption that the farming mix will not change significantly in South Gloucestershire, and therefore, the latest statistics for the number of poultry can be used.</li><li>• A bespoke CHP facility would be required to facilitate the use of the poultry litter.</li></ul>
<b>Sewage Sludge</b>	<ul style="list-style-type: none"><li>• The 2030 sewage sludge figure was determined by the tonnes of sewage produced per person per year and the predicted 2030 population of South Gloucestershire.</li><li>• A CHP enabled anaerobic digestion plant would be suitable for utilising sewage sludge to produce both electricity and heat.</li></ul>

For more information regarding the technologies used, see Section 1.8.6.

A detailed analysis of each waste stream can be found in Appendix M.

## 9.2 Waste Summary

A summary of the potential energy generation from the waste resource in South Gloucestershire is provided below. There are a number of key considerations which would impact whether the resource can be exploited:

- Viability of any investment in a plant;
- Existing arrangements and contracts; and
- Origin and price/gate fees of the resource.

High level consideration was given to the likelihood of the resource being exploited.

Although there is available food waste resource in the area, the waste is processed in Avonmouth, and it is understood that the existing arrangements are likely to be in place until 2030. Therefore, given resource availability is determined by where the generation takes place for the purposes of this report, it is assumed there is no available energy resource from food waste.

There is an existing large EfW site within the South Gloucestershire area, and therefore, the residual waste exported to the site is assumed to be existing generation.

A bespoke CHP plant would need to be used to facilitate the poultry litter resource. However, in practice, as the potential capacity is less than 10MWe, it is unlikely that this would be enough to support a dedicated poultry litter power plant since it is likely not to be viable. The resource has therefore been combined with slurries to be utilised in an AD plant with CHP

Given that there is already recovery of landfill gas utilised for electricity generation in South Gloucestershire, it is assumed that all economic opportunities are being exploited – hence the contribution is set to zero.

Therefore, the only available resources that can be utilised in AD plants within South Gloucestershire are animal slurries or sewage sludge.

When considering all of the above, the final potential for renewable energy from the waste resource is shown in Table 24 below.

**Table 24: Summary of Energy from Waste**

Resource	Technology	Prior to Consideration of Likelihood of Utilisation for RE Generation		Reason for Adjustment / Change of Technology	Post Consideration of Likelihood of Utilisation for RE Generation 2030		
		2030			Technology	MWe	MWt
		MWe	MWt				
C&I Waste	EfW with CHP	2.02	4.04	It is currently recycled, and the bulk of residual waste is exported to facilities outside South Gloucestershire. Therefore, it is counted as an existing generation elsewhere.	None	-	-
MSW	EfW with CHP	1.41	2.81	It is currently recycled. Non-recyclable material is exported to Severnside and Viridor energy recovery centres in South Gloucestershire and Bristol, respectively. Therefore, it is counted as existing generation in South Gloucestershire or elsewhere.	None	-	-
Food Waste	AD with CHP	0.53	0.80	Currently processed in Bristol Avonmouth, in the West of England. Assuming that the existing arrangements remain until 2030, the food waste is already accounted for as existing generation elsewhere.	None	-	-
Animal Slurry	AD with CHP	0.66	0.99	Combined with Poultry Litter	AD	1.150	1.970
Poultry Litter	Bespoke plant with CHP	0.49	0.98	Not likely to be enough resource for a bespoke plant. This resource is therefore combined with Animal slurry for AD with CHP above.	None	-	-
Sewage Sludge	AD with CHP	0.63	0.94		AD	0.63	0.94
Landfill Gas	Landfill gas recovery engine			There is a 9.76MWe installed capacity; it is assumed that all economic opportunities are exploited and is included within existing generation.	None		
<b>Potential installed capacity</b>		<b>5.74</b>	<b>10.56</b>			<b>1.78</b>	<b>2.91</b>

## 10. Hydropower

### 10.1 Introduction

Existing hydropower installations across South Gloucestershire have a combined total installed electrical capacity of 0.001MWe.

The Environment Agency published a high level, desked based study<sup>117</sup> into the potential for small scale hydropower generation across England and Wales in 2010, which was updated in September 2020<sup>118</sup>. Table 25 confirms the total potential hydropower capacity, including a breakdown of the potential hydropower sites' sensitivity to exploitation in the South Gloucestershire area. Where the sensitivity categories of potential sites were not given, the worst-case scenario was assumed, and it was assigned to have high environmental sensitivities.

For a list of potential hydropower sites from the Environment Agency study, see Appendix Q.

### 10.2 Hydropower Potential

Based on AECOM's previous studies investigating evidence in support of renewable energy potential on behalf of other local authorities, it was found that there was more generation occurring than could have been delivered by low and medium combined. Hence, it is an assumption that even where sites have a 'high' sensitivity rating, this does not necessarily preclude the development of such sites for power generation, presumably with environmental mitigation. It is therefore proposed that the potential hydropower resource across South Gloucestershire, subject to appropriate investigation, could comprise those sites of medium sensitivity and 25% of the high sensitivity sites<sup>119</sup>, equating to 0.32MWe in total without considering potential uptake, deliverability and existing schemes.

**Table 25: Potential Hydropower Capacity in South Gloucestershire According to Environmental Sensitivity.**

Environmental Sensitivity	Installed Capacity (MWe)
Low	0
Medium	0.06
High	1.05
<b>Total</b>	<b>1.11</b>
Proportion High Sensitivity Included	25%
<b>Potential Hydro Power Resource</b>	<b>0.32</b>

Moreover, within the study published by the Environmental Agency, some of the sites were highlighted as win-win sites<sup>120</sup>; within South Gloucestershire, only 1 site was highlighted. This information is shown in Table 26.

<sup>117</sup> Mapping Hydropower Opportunities and Sensitivities in England and Wales: Technical Report, Entec UK on behalf of Environment Agency (2010)

<sup>118</sup> Potential Sites of Hydropower Opportunity, Environment Agency, revised 2020; <https://data.gov.uk/dataset/cda61957-f48b-4b75-b855-a18060302ed1/potential-sites-of-hydropower-opportunity>

<sup>119</sup> Sites with high environmental sensitivity will be less desirable than those with medium or low sensitivities due to their environmental impact. The sites are highly sensitive, mainly due to the presence of migratory fish species such as salmon and eel. However, they become more environmentally compatible opportunities when a new scheme has a fish pass built on it. Based on this and AECOM's experience, it is deemed that 25% of the high sensitivity sites should be considered when determining potential hydropower installed capacity because there could be lower uptake of the sites due to higher cost of additional environmental mitigations as well required permits.

<sup>120</sup> The Environmental Agency's judgement on whether the site is a potential "win-win" for both hydropower and the environment



**Table 26: Proportion of Potential Sites in South Gloucestershire Outlined as Win-Win Sites**

Win-Win Sites	
River Obstruction Sites	66
Win-Win Sites	1
Percentage Win-Win Sites	1.51%

### 10.3 Summary

The Environmental Agency study highlights the minimal potential for hydropower generation within South Gloucestershire, with a potential hydropower capacity of 0.32MWe based on AECOM's assessment. Furthermore, a significant number of the potential sites are located within an area of high sensitivity, and only one site (less than 2% of the sites) is considered a Win-Win site.

Therefore, it is concluded that no further practical potential hydroelectric capacity is available in South Gloucestershire. It should be noted that technological advances could enable more sites to become a Win-Win solution.

## 11. Role of Storage in the Network

### 11.1 Introduction

As part of the RERAS, the analysis undertaken of the role of storage in the network has been conducted by Regen<sup>121</sup>. This section sets out the key findings of this analysis.

Electricity storage has a vital role to play in enabling a zero-carbon electricity system and facilitating the UK's transition to net zero. Electricity can be stored using several technologies and then exported to provide various services to the electricity system.

#### **Reserve (reserves, time shifting, back-up supply)**

The fundamental use for storage is storing electricity for use at a later time. As renewable output varies according to weather conditions, storage provides reserves for use when demand is high, when supply is low, or at times of system stress.

For individual customers, storage can provide the ability to 'time shift' energy or provide a back-up supply behind the meter when an existing network connection is lost or interrupted. This could be done for a variety of reasons but is most often to take advantage of market price fluctuations and avoid peak electricity network charges.

#### **Frequency Control (system inertia, frequency response)**

As the amount of renewable generation on the system increases, the variability of the system's frequency also increases. An optimal frequency range is needed to maintain the grid's stability - an imbalance between demand and generation will affect frequency. Most renewable generation does not currently provide the required inertia. Overall, system inertia decreases, and as a result, the frequency can change very quickly and cause instability in the system.

Storage can help address this issue in two ways: by providing inertia, either real or synthetic, or through frequency response. Storage, particularly battery storage, can respond in milliseconds, helping the system deal with rapid changes in frequency.

#### **Flexibility (constraint management, investment deferral)**

Grid infrastructure (wires, transformers etc.) requires regular upgrades to handle increases in demand and generation. As the electricity system becomes increasingly decentralised, with generation connecting to lower voltage networks, existing infrastructure is not able to cope, resulting in constraints.

Expensive, time-consuming infrastructure upgrades may be necessary, but storage can help reduce these costs by supporting the network during periods of constrained generation or high demand, thus alleviating such constraints at a local level. This reduces the amount of new infrastructure needed or allows upgrades to be deferred to a more appropriate time.

#### **Co-location with renewables**

Storage can provide reserve and time-shifting directly to the renewable generating plant, storing excess energy when it is not needed by the grid.

There are times of low-demand and high generation, for example, during the summer months. Renewable generation is increasing, whilst the requirement for this energy is decreasing,

Generators are paid by the Electricity System Operator (ESO) to 'turn down' at times of high generation and low demand; however, these payments may not be commercially viable or even available in future, making co-located storage a more attractive prospect.

However, storage may be underutilised if it is only used for this purpose and may also need to provide other services in order to make full use of the asset. Currently, there are several co-located storage

---

<sup>121</sup> <https://www.regen.co.uk/about-us/>

sites, but most only share a grid connection with renewable generation, not an operating model. Therefore, although the storage sites and renewable generation are in the same place, they are not being used together, e.g. the battery is not being used to store excess generation from the renewable generator to avoid curtailments.

### Long duration and seasonal storage

Currently, many of the services described above are either being met with lithium-ion battery storage, with around 0.5 - 2hour duration, or pumped hydro, lasting several hours. However, the case for longer-duration storage is growing. There is no agreed-upon definition of 'long-duration storage' but splitting storage into broad categories may help focus the debate.

Currently, the ESO is not asking for services from storage for a duration beyond a few hours, but the need for longer duration and even seasonal storage may increase as we see high renewable penetration and electrification of heat, for example, storing some surplus solar generation in the summer, for use on winter evenings<sup>122</sup>.

## 11.2 Local Insights

### 11.2.1 Distribution Future Energy Scenarios projections

Western Power Distribution's (WPD) Distribution Future Energy Scenarios (DFES) scenario-based projections of battery storage uptake falls under four key business models:

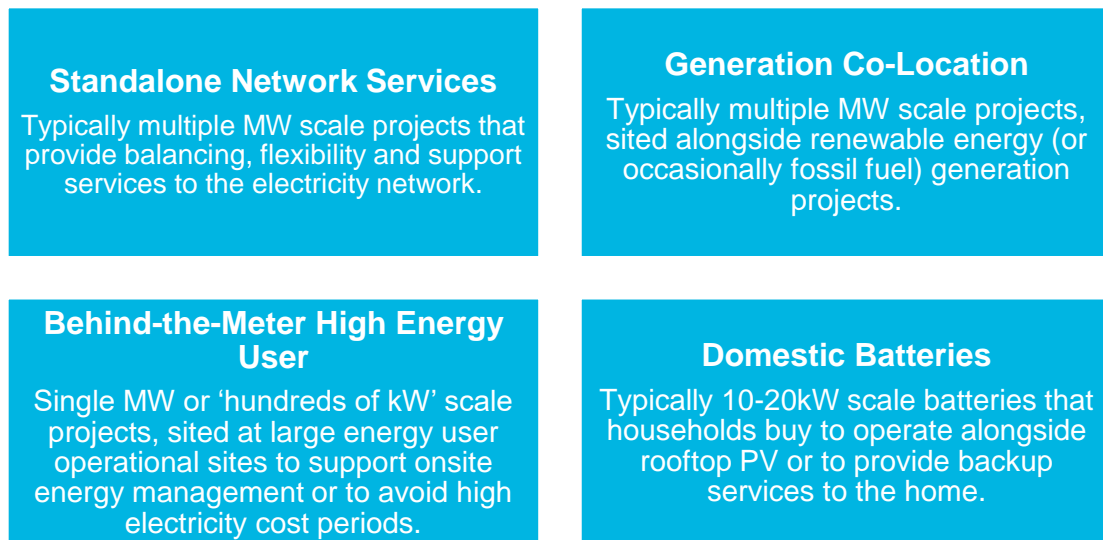

These models are all viable in their own way, but it is not necessarily suitable to compare their respective viability due to their individuality and very different circumstances.

There is one known planned co-located battery storage project in the region. Located at Alveston Wind Farm in South Gloucestershire, the planned 10 MW battery has planning permission and has an accepted grid connection offer.

Figure 51 illustrates the scenario-based projections of battery storage installed capacity in each area:

<sup>122</sup> For further information on electricity storage's role in a net zero future see Regen's 2020 paper: Electricity Storage: Pathways to a Net Zero Future

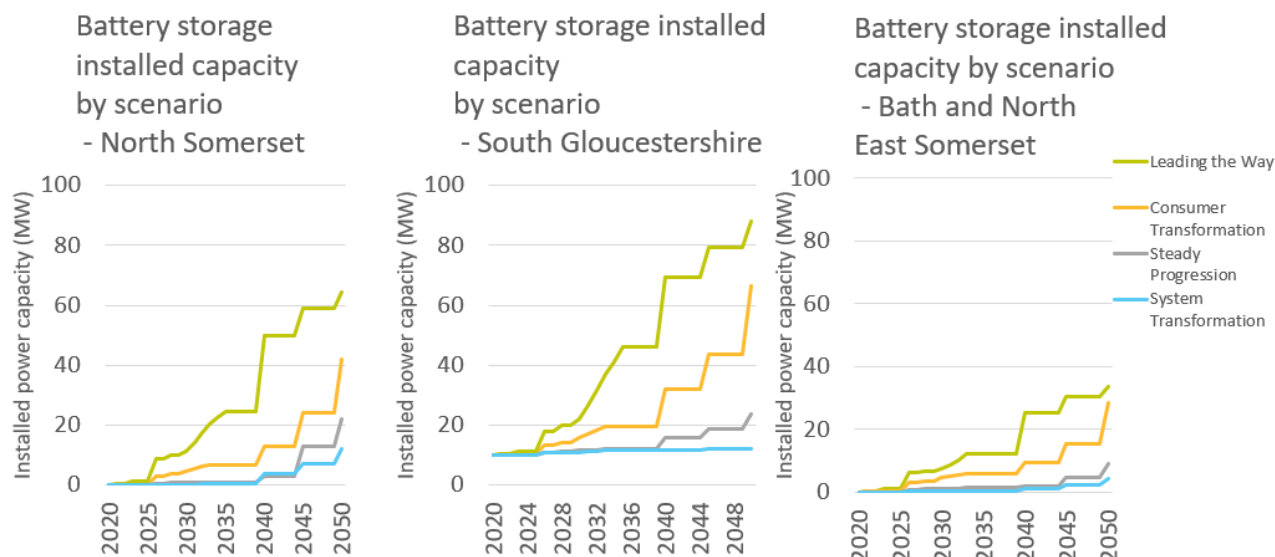

**Figure 51: Distribution Future Energy Scenarios Battery Storage Projections<sup>123</sup>**

The majority of projected battery storage capacity under the DFES analysis is from domestic batteries and high energy users within the region. There are small increases in batteries co-located with the generation due to a relatively small increase in generation sites within the region when compared to elsewhere in WPD’s network. Furthermore, there is little projected increase in standalone grid service batteries due to fewer estimated suitable connection opportunities in the region compared to elsewhere in WPD’s network.

### 11.2.2 Planning activity

Three battery storage projects at different stages of development were identified in South Gloucestershire from reviewing the Department for Business, Energy and Industrial Strategy (BEIS) Renewable Energy Planning Database. Table 27 provides a summary of these projects.

**Table 27: Battery Storage Projects<sup>124</sup>**

Operator (or Applicant)	Site Name	Installed Capacity (MW)	Planning Status	Comments
FPC Industry & Enterprise	Severn Road (South Glos)	18	Planning Permission Granted	Active in T-1 and T-4 Capacity Market auctions.
Ecotricity	Old Green Farm, Alveston Battery Storage (South Glos)	10	Planning Permission Granted	Believed to have been constructed alongside Alveston Wind Farm
Enso Energy / Iron Acton Green	Larks Green Solar Farm (South Glos)	Unknown	Planning Permission Granted	No development activity identified

### 11.2.3 District Network Operator Constraint Management Zones

Distribution Network Operators (DNOs), including WPD, are looking to procure flexibility services at a local level to support the network. There are three flexibility services within so-called Constraint Management Zones (CMZs), and each caters to different network requirements. These are as follows:

<sup>123</sup> WPD, 2020. Distribution Future Energy Scenarios 2020 South West Licence Area: Results and Assumptions report; <https://www.westernpower.co.uk/downloads-view-reciteme/228130>

<sup>124</sup> BEIS, 2020. Renewable Energy Planning Database; <https://www.gov.uk/government/publications/renewable-energy-planning-database-monthly-extract>

**Secure Service (pre-fault  
constraint management)**

Used to manage peak demand loading on the network and pre-emptively reduce network loading.

**Dynamic Service (post-fault  
constraint management)**

Used to support the network in the event of specific fault conditions, often during summer maintenance work.

**Restore Service  
(restoration support  
management)**

Intended to help with restoration following rare fault conditions. Such events are rare and offer no warning as they depend on failure of equipment.

It should be noted that all of these services could support storage projects. However, they are all circumstantial and will not always be suitable or available to all storage projects. They would need to be in a location in which all services are required. A key limiting factor is the duration that these services will require a response for versus the energy storage capacity.

### 11.3 Summary

As renewable energy development and heat electrification increase, the need for longer duration and seasonal storage will increase. Progress is already being made within South Gloucestershire regarding battery storage, with three storage projects currently in different stages of development.

The Consumer Transformation DFES scenario shows a continual increase in battery storage capacity within South Gloucestershire between 2020 and 2050. It is likely that the majority of the projected battery storage capacity is from domestic batteries, as the Consumer Transformation scenario assumes a shift to the integration of renewable energy generation technologies into homes.

However, there is likely to be a need to increase the amount of co-located batteries in conjunction with installations of solar and wind farms due to insufficient capacity on the grid and to avoid any curtailment. A ranking exercise has therefore been undertaken by WPD in relation to ease of grid connectivity of the Search Areas (SAs) for wind and solar PV farms identified in this study (see Figure 42 and Figure 43 in Section 10). The highest ranked ('5' in the relevant maps) may not require storage to avoid curtailment but other SAs e.g. those ranked 2 or 3, might.

In such cases, developers will need to explore options as part of project development to understand viability. Part of such viability studies will include discussions with WPD but also proximity to electricity demands and the ability to sell any electricity produced to third parties. The Council and other public and private sectors might co-locate to take advantage of any available renewable electricity. This should be considered when sieving potential candidate sites (defined as potential development sites for housing or employment for the purposes of this report) for the Local Plan or when the public and/or private sector are considering options for locating services that are significantly power dependent. These complementary loads would benefit from battery storage installations which may remove the necessity to have a grid connection in areas where the grid is constrained.

#### **Policy Recommendation**

##### **Policy Reference: ES-PR-1 (Refer to Table 41 in Section 17)**

It is recommended that policy encourages applicants promoting schemes for renewable electricity generation of >1MW, regardless of technology, to consider including storage as part of their proposal. This could include some form of energy storage (green hydrogen production, seasonal or battery storage), private wire supply or evidence as to why this is not feasible or viable.

Higher resolution versions of these maps are contained in the accompanying document ‘South Gloucestershire RERAS – Maps’.

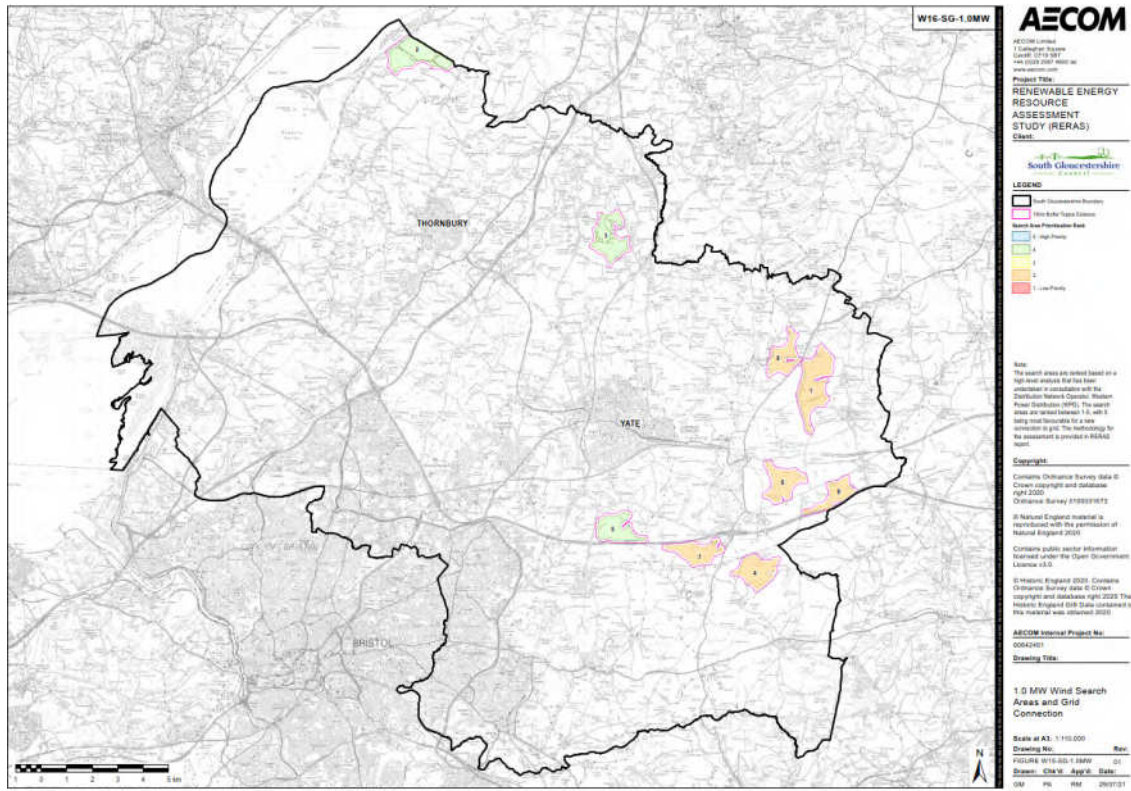

Figure 52: W16-SG-1.0MW: 1.0MW Wind Search Areas and Grid Connection in South Gloucestershire Map

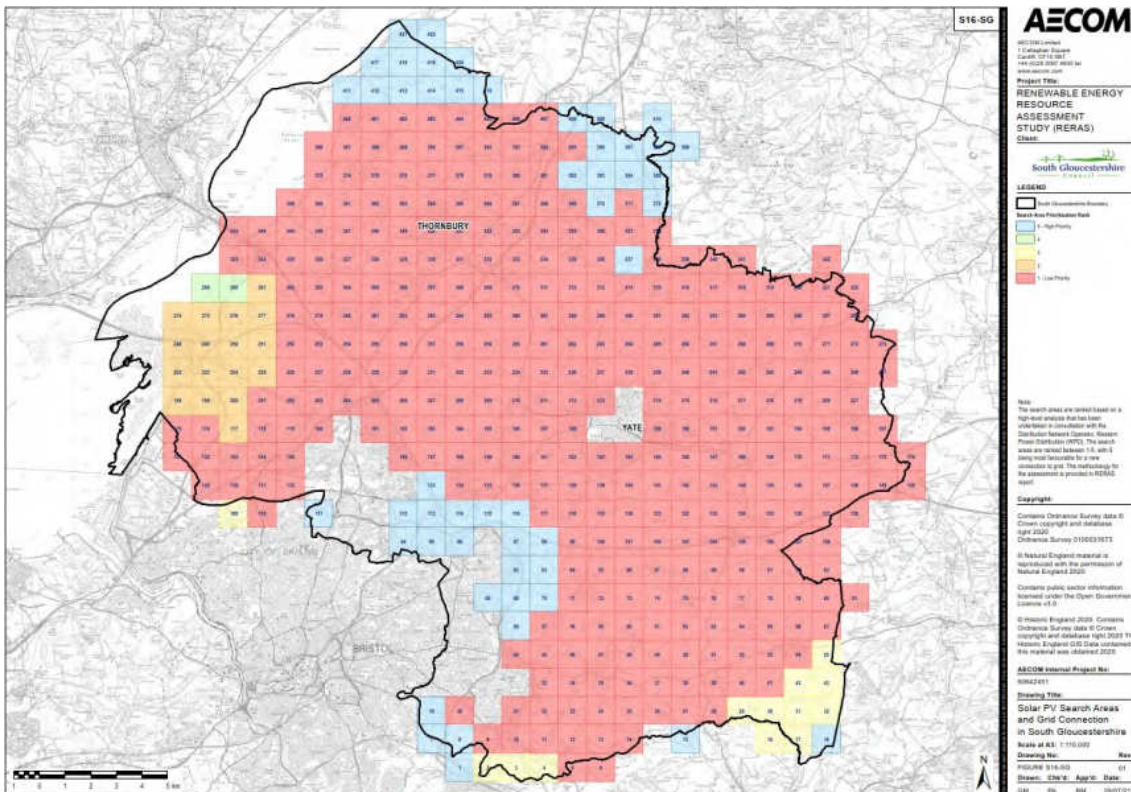

Figure 53: S16-SG: 50MW Solar PV Search Areas and Grid Connection in South Gloucestershire Map

## 12. Hydrogen

### 12.1 Introduction

Hydrogen is set to play a critical role in enabling the UK economy to achieve net zero carbon. As well as providing a low carbon energy source for difficult to “decarbonise” sectors, such as heavy transport, aviation and various industrial processes, hydrogen could also play an important role in system balancing as a multi-vector fuel (a fuel that can be produced or consumed across different energy sectors), using very low-cost electricity during times of over-supply to convert, store and transport renewable energy for applications across the energy system.

Hydrogen is typically classified by its generation technology which is denoted by different colours. There are three main colours of hydrogen<sup>125</sup>. These colours are as follows:



#### Grey Hydrogen

Grey hydrogen is made using fossil fuels. This process emits CO<sub>2</sub> into the atmosphere as they combust



#### Blue Hydrogen

Blue hydrogen is made using fossil fuels, but carbon capture technology is used to prevent the emission of the CO<sub>2</sub> produced



#### Green Hydrogen

Green hydrogen is the cleanest, producing zero carbon emissions. Green hydrogen is produced via electrolysis powered by renewable energy

Whether the optimal supply chain for a particular hydrogen market is best served by a small number of very large manufacturing plants, enjoying economies of scale in production, or by a larger number of distributed production facilities located near to consumers to allow lower storage and distribution costs is yet to be seen. However, evidence from the existing hydrogen market suggests that the initial market driver is towards production plants located within industrial and chemical process clusters and transport hubs, with relatively short or onsite distribution channels.

There are also very different value chains for hydrogen, with gas network blending low value, but also relatively low cost. In contrast, hydrogen for transport is likely to command a higher price per energy unit. This is important as the cost of hydrogen is not yet competitive with electricity or traditional fuels, so it is unlikely to be economically viable if used in a low-value application.

For more information on the production of Hydrogen, please see Section 1.8.9.

<sup>125</sup>Turquoise hydrogen is created when natural gas is broken down with the help of methane pyrolysis, additionally pink hydrogen is generated through electrolysis powered by nuclear energy. Nuclear-produced hydrogen can also be referred to as purple hydrogen or red hydrogen.

## The hydrogen value chain

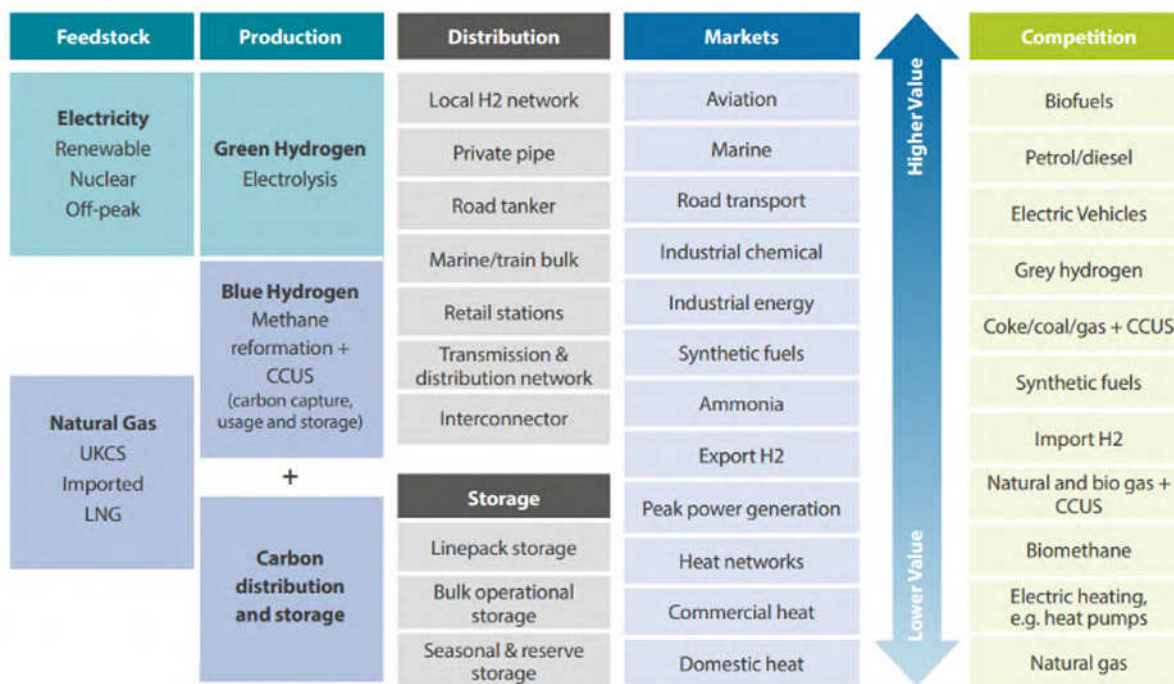

Figure 54: The Hydrogen Value Chain. Source: Regen, 2021<sup>126</sup>.

As Figure 54 above illustrates, there are distinct markets and value propositions for hydrogen products; these range from existing uses, new high-value applications in transport and industrial processes, and potentially lower-value applications as a fuel for heating or to generate electricity.

Pushing hydrogen as a replacement for natural gas for heating would be a significant strategic decision. It would require long-term policy interventions at a national level, such as applying a very high carbon tax while providing a long-term fuel subsidy. It is likely that hydrogen for heating will emerge from a much more targeted strategy, providing fuel for heat networks and localised distribution networks in areas that are otherwise hard to decarbonise.

Some commentators have suggested that using hydrogen for domestic heating would allow consumers to avoid the cost and disruption of energy efficiency measures. This would be a mistake; high hydrogen costs and seasonal peak demand mean that using hydrogen for domestic heating would require just as high levels of energy efficiency as any other low carbon heating option.

In the short term, hydrogen innovation projects are likely to take advantage of surplus renewable energy, existing gas networks or large-scale industry to develop hydrogen hubs. Innovative projects such as these could facilitate the creation of a route to market for hydrogen in what is still a relatively young industry<sup>127</sup>.

## 12.2 Hydrogen Projects in the West of England

No existing hydrogen production facilities have been identified within the West of England region, nor have any planned pipeline hydrogen production facilities. However, a number of projects have been identified at various stages of development that may consume hydrogen, including:

- [GKN hydrogen-powered plane project lands £54m as part of UK drive towards innovation \(Jan 2021\);](#)
- [ZeroAvia to develop a HyFlyer II at Cotswold Airport \(April 2021\);](#)
- [Hydrogen trams could be transport solution for Bath \(Aug 2020\);](#)

<sup>126</sup> Building the Hydrogen Value Chain; <https://www.regen.co.uk/publications/building-the-hydrogen-value-chain/>

<sup>127</sup> For further information on the hydrogen value chain, see Regen’s 2021 Insight Paper on ‘Building the Hydrogen Value Chain’; <https://www.regen.co.uk/publications/building-the-hydrogen-value-chain/>



- [Ambition to launch hydrogen-powered water taxis between Bristol and Cardiff \(July 2020\)](#);
- [Bristol hydrogen taxis](#) (existing project);
- [M4 hydrogen corridor could extend into the region.](#)

Furthermore, National Grid's 'Future of Gas' paper<sup>128</sup> does not identify any hydrogen projects in the region and the closest hydrogen project is in Swindon.

## 12.3 Local Opportunities

There are potentially several industrial processes in South Gloucestershire for which green hydrogen could provide a critical low carbon energy source. The map below identifies potential industrial clusters in the region, prioritising those more likely to entail chemical processes and high-grade heat requirements for which hydrogen could be a feedstock or low carbon fuel.

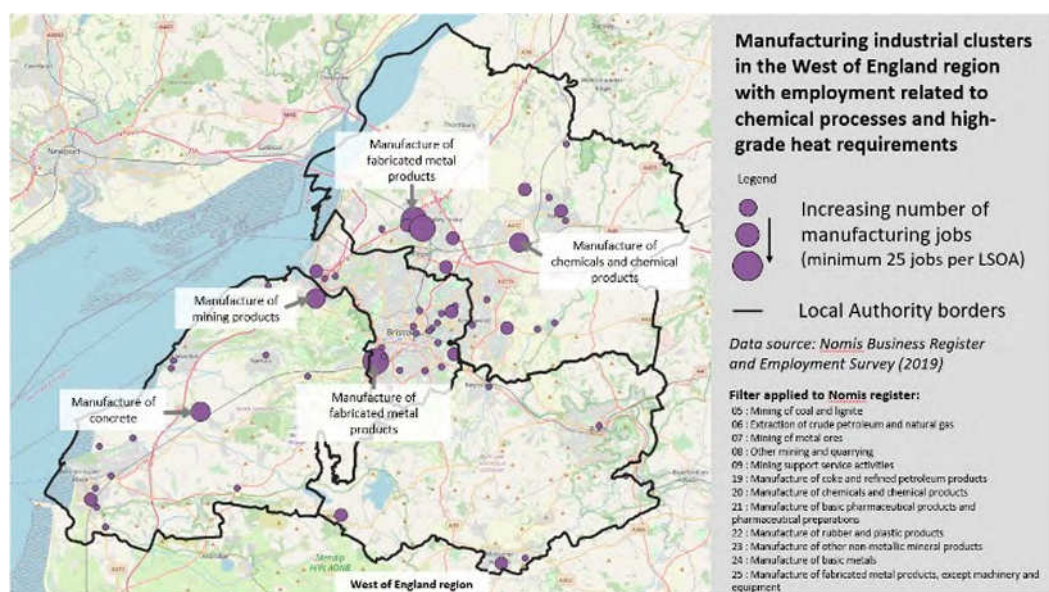

**Figure 55: Manufacturing Industrial Clusters in the West of England With Employment Related to Chemical Process and High-Grade Heat Demand<sup>129</sup>.**

Synthetic hydrocarbon fuels could play a significant role in achieving net zero in otherwise challenging to decarbonise industries such as aviation. Aerospace supplier GKN, based in South Gloucestershire, is working with partners on a project called [H2GEAR](#), which has received funding to develop a way to power planes using hydrogen. Hypothetically, work from this project could contribute to decarbonising the aviation industry.

## 12.4 2030 Hydrogen Demand in South Gloucestershire

It is projected in DFES<sup>130</sup> and Regen calculations that a total of 501GWh of electricity will be required for grid-connected (electrolysis) hydrogen generation in 2030; it should be noted that the aims for South Gloucestershire have been condensed from 2050 to 2030 to align with the Climate Emergency declaration. See Section 14 for more detail.

The Consumer Transformation scenario from DFES (see Figure 56), utilised in this RERAS, assumes a proportion of the total hydrogen demand will be met from hydrogen generation via methane reformation and carbon capture and storage (see Figure 57<sup>131</sup>).

Whilst green hydrogen production requires renewable electricity that could be available in 2030, as hydrogen is a new energy carrier, it could be that the required infrastructure (e.g. the electrolyzers,

<sup>128</sup> <https://www.nationalgrid.com/uk/gas-transmission/document/132471/download>

<sup>129</sup> Data source: Regen analysis - Nomis employment survey data.

<sup>130</sup> See Section 13 for more information regarding DFES.

<sup>131</sup> Future Energy Scenarios, National Grid ESO, July 2020; <https://www.nationalgrideso.com/document/173821/download>

gas distribution network and/or domestic and commercial hydrogen boilers assumed in DFES) to employ the green hydrogen will be challenging to put in place by 2030.

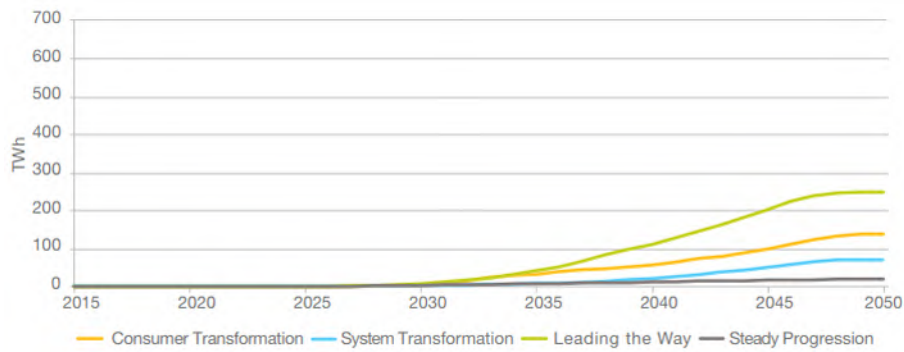

Figure 56: Electricity Demand for Hydrogen Production in the UK<sup>132</sup>

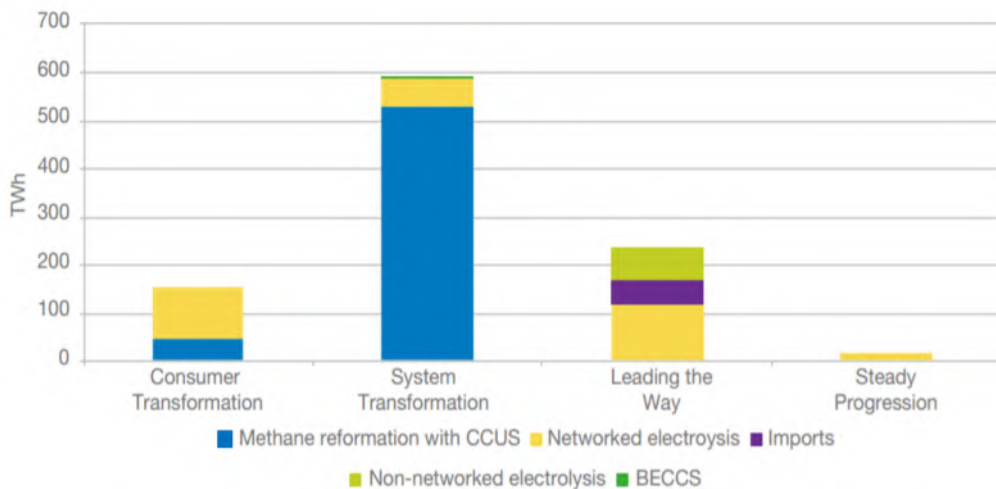

Figure 57: FES 2050 Hydrogen Supply for the UK<sup>133</sup>

## 12.5 Mapping

Map titles and references:

1. H1-SG: Wind Local Search Areas and Industrial Clusters for Potential Green Hydrogen Generation and Demand
2. H2-SG: Solar PV Local Search Areas and Industrial Clusters for Potential Green Hydrogen Generation and Demand

H1 and H2 maps illustrate locations of the identified solar PV and wind Search Areas in relation to the industrial manufacturing clusters in South Gloucestershire with employment related to chemical processes and high-grade heat demand. It should be noted since RERAS does not appraise consideration of hydrogen infrastructures such as hydrogen transport or storage, the mapping is concentrated on identification of industrial use and does not cover all of the hydrogen usage envisaged in DFES. The Search Areas (SAs) in proximity to the industrial clusters can potentially be utilised for green hydrogen generation. Additionally, the maps include large surface waters, which are required for electrolysis hydrogen generation production.

<sup>132</sup> National Grid, Future Energy Scenarios, Electricity Demand for Hydrogen Production in the UK, July 2020:

<https://www.nationalgrideso.com/document/173821/download>

<sup>133</sup> National Grid, Future Energy Scenarios, 2050 Hydrogen Supply for the UK, July 2020:

<https://www.nationalgrideso.com/document/173821/download>

**Policy Recommendation**

**Policy Reference: ES-PR-2 (Refer to Table 41 in Section 17)**

It is recommended that applications for renewable electricity generation of >1MW, located within 1km of an industrial cluster identified as having potential for hydrogen production, consider utilising outputs (via private wire) for such purposes.

**Policy Recommendation**

**Policy Reference: ES-PR-3 (Refer to Table 41 in Section 17)**

Building on ES-PR-2, it is recommended that applications for new industrial development that may have a use for green hydrogen should be guided towards locations near/in 'hydrogen clusters' wherever practical.

Higher resolution versions of these maps are contained in the accompanying document 'South Gloucestershire RERAS – Maps'.

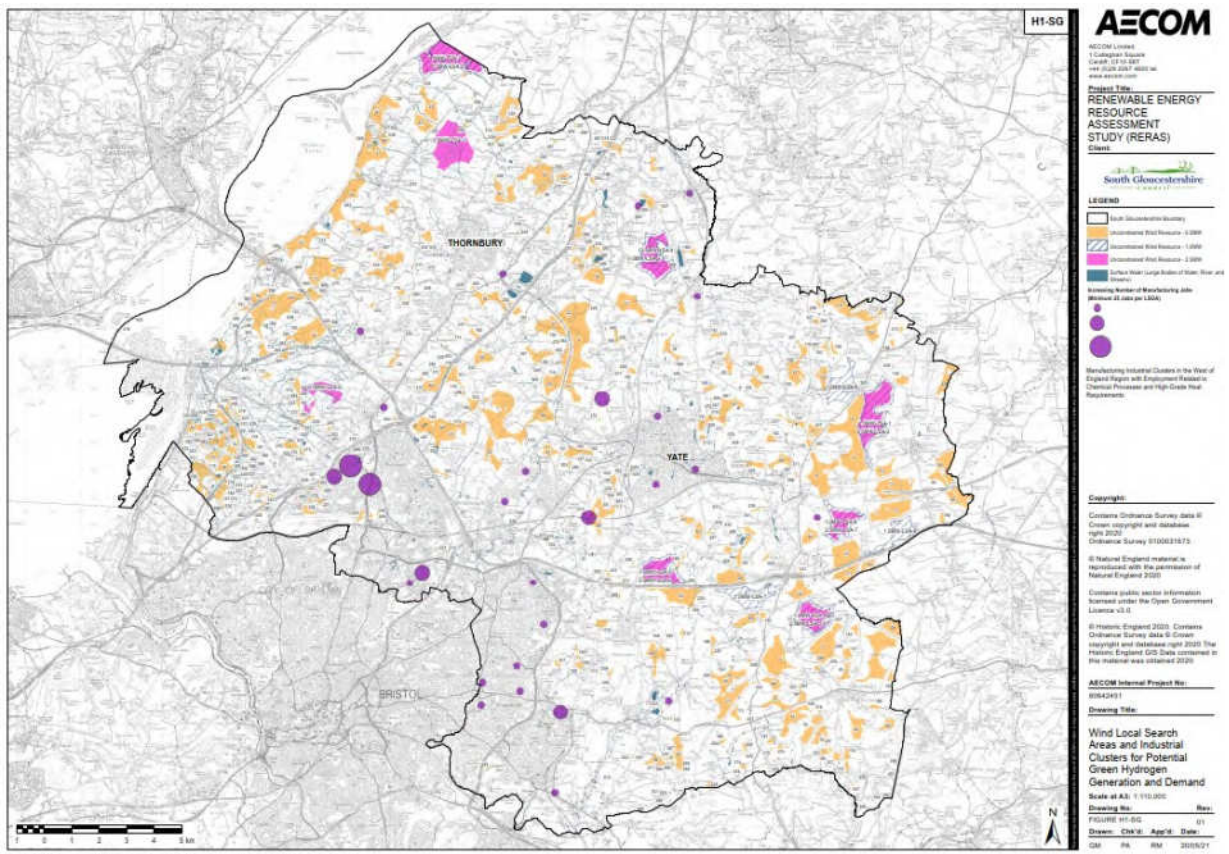

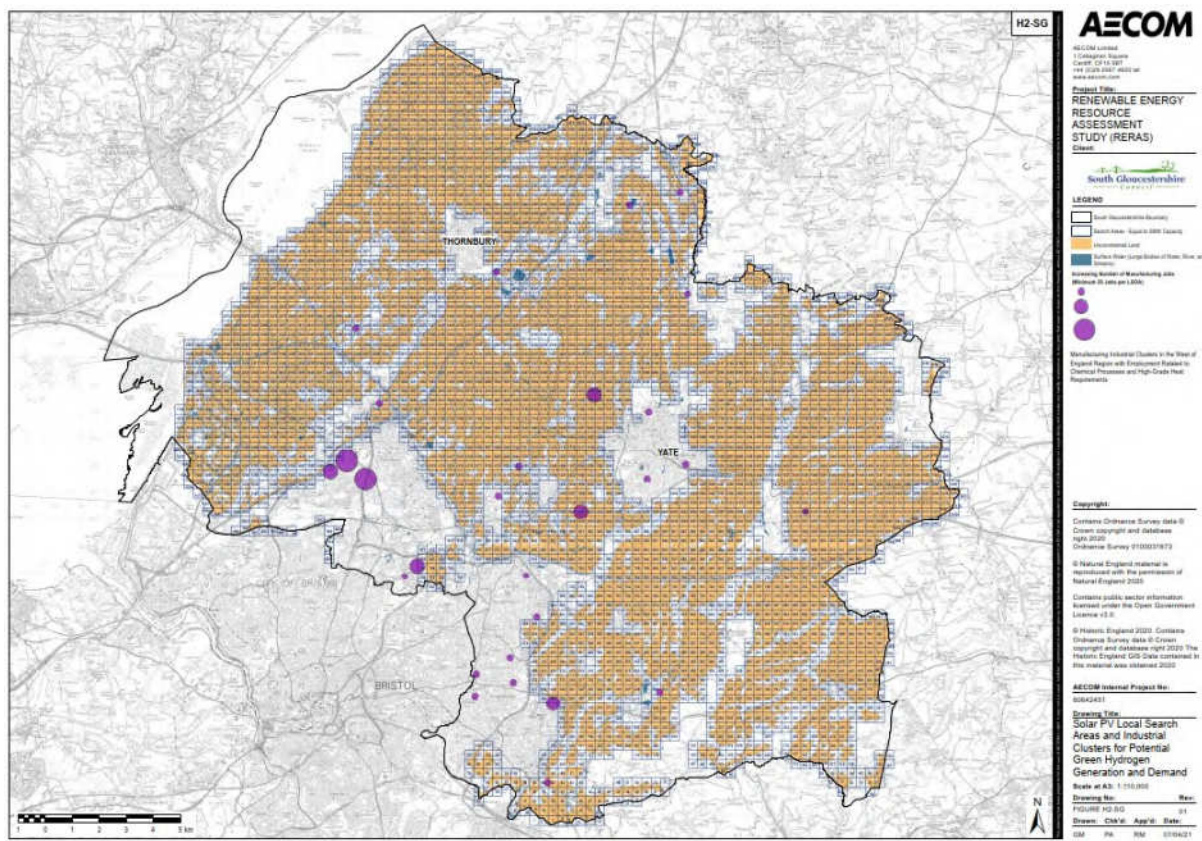

**Figure 59: H2-SG: Solar PV Local Search Areas and Industrial Clusters for Potential Green Hydrogen Generation and Demand Map**

### 12.6 Potential Opportunities for Future Development

Many potential industrial clusters were identified in the mapping process; a significant number being sites located near the identified solar PV and wind SAs. As it stands, infrastructure with the potential to support hydrogen generation is likely to be developed in these locations. The SAs could provide renewable electricity to produce ‘green hydrogen’ and so it is suggested that these sites are kept in mind so that all potential opportunities to generate green hydrogen are realised.

## 13. Heat Opportunity and Strategic Site Assessment

### 13.1 Introduction

Heat is typically generated at a building level, which means that only small-scale technologies can be used (most commonly gas boilers), limiting the use of other forms of low and zero-carbon heat generation technologies. Unlike decarbonisation of the power sector, decarbonising heat at scale could directly impact consumers, requiring changes to the majority of the heating systems currently in buildings and industrial sites<sup>134</sup>. Additionally, sufficient heat demand should exist in proximity of a heat source to make development viable, making decarbonisation of heat more challenging. A 'Heat Opportunities Map' is created in this section of the study that presents locations of heat demand clusters and potential heat sources in South Gloucestershire.

A District Heating Network (DHN) refers to a distribution system providing multiple individual buildings with heat generated from one or more sources. The plant is generally housed in a building known as an energy centre. DHNs comprise a system of insulated pipes, known as heat mains, which distribute hot water from the energy centre to several different buildings to provide space heating and hot water. Each building has a heat interface unit (HIU) that supplies heat from the network to the local building distribution system instead of individual boilers. New controllers are provided (very similar to those fitted and linked with gas boilers) to operate the system, and buildings can usually retain their internal distribution system (e.g. radiators). Heat is metered and billed to consumers in much the same way that gas or electricity is. This is combined with a service charge to cover maintenance of the shared distribution system (electricity and gas bills also incorporate a charge for these services). Schemes can range in size from simply linking two buildings together to spanning entire cities.

NPPF requires planning authorities to identify a range of suitable sites within their area to meet the scale and type of development likely to be needed. The identification could cover housing and employment sites, and the planning policies and decisions need to reflect changes in the demand for land. They should be informed by regular reviews of both the land allocated for development in plans and of land availability<sup>135</sup>. Heat opportunities mapping presented in this section can assist the Council to identify or rank potential development sites based on DHN potential.

District heat offers an alternative to the typical arrangement, offering efficiencies of scale by generating and distributing heat to a number of buildings or utilising a source of heat that would otherwise be wasted. This would include access to otherwise wasted forms of heat, not viable at a building scale, including the use of waste heat from local power generation or energy from waste plants, local rivers, bodies of water or mines. Waste heat can be considered a low carbon option as it offsets the new end-users need for additional heating fuel. Deployment of low-carbon technologies at a network level can also utilise large thermal storage allowing for wider energy system balancing at a cost far lower than many chemical or alternative batteries.

Assessing the potential for a district heat network within South Gloucestershire could offer many potential benefits for the Council:

- CO<sub>2</sub> emissions reductions – the combination of more efficient generation and the ability to use alternative technologies and fuels means that district heat networks can provide significant CO<sub>2</sub> reductions.
- Emissions reductions in hard-to-treat buildings – where retrofitting fabric improvements to existing stock is challenging (e.g. for listed buildings), district heat provides an alternative method by which to reduce CO<sub>2</sub> emissions.
- Reduction in energy prices – increased efficiencies can lead to reduced energy costs for customers. This can mean improved competitiveness for local businesses and reduced energy bills and the alleviation of fuel poverty for households.
- Identification or ranking of potential development sites for future development based on DHN potential.

<sup>134</sup> [https://assets.publishing.service.gov.uk/government/uploads/system/uploads/attachment\\_data/file/766109/decarbonising-heating.pdf](https://assets.publishing.service.gov.uk/government/uploads/system/uploads/attachment_data/file/766109/decarbonising-heating.pdf)

<sup>135</sup> [https://assets.publishing.service.gov.uk/government/uploads/system/uploads/attachment\\_data/file/1005759/NPPF\\_July\\_2021.pdf](https://assets.publishing.service.gov.uk/government/uploads/system/uploads/attachment_data/file/1005759/NPPF_July_2021.pdf)

The consideration of a district heat network could be a viable method to help bridge the gap between the projected 2030 heat demand and the maximum theoretical resource identified in this study (see Section 15.2). When analysing the viability of a DHN, there are multiple stages that vary in complexity:

- Heat opportunities mapping;
- Assessing the technical and financial viability of district heating networks; and
- Developing a heat-opportunities plan for district heating networks.

Heat opportunities mapping, which is presented in this study, provides sufficient levels of detail to allow the Council to identify or rank potential development sites based on DHN potential. The data and maps can also be utilised in setting policies requiring developers to investigate heat networks. However, any policy requiring site/building specific CO<sub>2</sub> reduction targets, or connections to DHN, will require a more detailed economic and technical appraisal.

## 13.2 Heat Opportunities Mapping Process

The nature of existing energy demand and infrastructure is identified in this section. There are multiple reasons for this, including (but not limited to):

- Identification of public sector buildings to act as anchor 'heat' loads (AHLs);
- To establish the energy densities of particular areas. District Heating technology installations are more likely to be economically viable in areas of high-density energy demand but can be more complex to install;
- The proportions of the relative demand for electricity and heat are also useful indicators as to what type of Low and Zero Carbon (LZC) technologies might be appropriate in a particular area; and
- Areas of high-density energy demand may not always present the greatest opportunities. Energy density data needs to be combined with other data, such as the nature of energy demand, the composition of building types and uses, the accessible renewable energy resource, land and building ownership, existing infrastructure and any proposed development in order to identify the greatest opportunity. These opportunities should also be reviewed against community priorities to align delivery to local requirements.

### 13.2.1 Identifying Anchor "Heat" Loads and "Clusters"

Anchor Heat Loads (AHLs) pertain to buildings with a high and continuous demand that could provide economically viable and practical opportunities for utilising heat. It is known as an 'anchor' load because further opportunities may arise for connecting nearby buildings to the original anchor load. An AHL, therefore, refers to a building energy load that can act as a base for a District Heating (DH) scheme.

Buildings (such as social housing, etc.) located near an AHL and which may benefit from and contribute to the viability of DH schemes are known as a 'cluster'. A 'cluster' usually refers to a mix of residential and non-residential buildings which, together, represent opportunities due to their:

- Suitable energy demand profile;
- Planned development programme;
- Commitment to reduce CO<sub>2</sub> emissions.

The identification of AHLs and clusters requires the mapping of:

- Buildings owned by organisations with corporate climate change mitigation policies and an active commitment to reducing their carbon footprint; and
- Social housing schemes. These organisations are often tasked with achieving greater than the minimum environmental performance standards. Including such developments in DH schemes often enhances the energy profile to provide further evening, weekend and night-time energy demands; and

- New planned developments.

AHLs can help a DH scheme to become a realistic prospect, and there are usually particular conditions that need to be in place, such as planned new development and/ or an AHL building/ group of buildings with significant demand for heat and/ or with an energy profile suitable for the installation of a particular technology.

Privately owned buildings are less often utilised as AHLs due to more attractive returns from competing investments, reduced willingness to commit to long term energy procurement contracts and other issues such as a greater tendency for private companies to rent property rather than own it. In the residential market, it is preferable for district heating schemes to connect to social housing, particularly apartment blocks, due to the increased heat demand density offered. It is often impractical for developers to have to negotiate with many individual private householders, whereas social landlords can more readily act on behalf of their tenants. It should be noted that in this RERAS, the buildings are identified and mapped based on the Council's Local Land and Property Gazetteer (LLPG) data, which allows for identification of building type and use but does not provide information on the ownership type of the buildings, however, the council-owned sites are identified and marked on the maps.

In order to calculate the heat demand of the non-residential buildings, the following methods and sources are used.

- Metered energy data provided by the Council;
- Display Energy Certificates (DEC), if metered data is not available; and
- Chartered Institute of Building Services Engineers Technical Memorandum TM46 energy benchmarking conversions (only incorporated if DEC or metered data are not provided).

#### 13.2.1.1 Social Housing Associations in South Gloucestershire

Housing Associations in South Gloucestershire included on the maps are as follows:

- Alliance Homes;
- Anchor Hanover;
- Stonewater;
- Selwood Housing; and
- United Communities.

This list is not intended to be an exhaustive list of organisations active in the area as only the above organisations responded to the request for information document sent to collect the relevant information.

#### 13.2.2 Mapping Residential Heat Demand and Density

A report for BEIS (formerly DECC<sup>136</sup>) suggests that DHNs are not feasible unless a heat demand of at least 3MW/km<sup>2</sup> is present.

'Density' of heat demand refers to kilowatt-hour (kWh) / square kilometre (km<sup>2</sup>) of heat energy consumed in dwellings. When allocating energy consumptions to existing residential buildings, the publicly available domestic gas consumption estimates per Lower Super Output Area (LSOA) for 2019 was used to allocate each area a heat density figure and quantify the heat demand.

The importance of identifying residential heat demand and density pertains to:

- The potential demand for heat in any one particular area;
- Contributing to the identification of AHLs;
- Feeding into the analysis of potential LZC solutions;

---

<sup>136</sup> The Potential and Costs of District Heating Networks. A Report to the Department of Energy and Climate Change, April 2009

- A mix of buildings and energy uses which, together, represent a potential complementary energy demand profile (dwellings providing evening, weekend and night-time energy demands as opposed to the regular weekday energy demands of commercial organisations); and
- The identification of opportunities relating to social housing providers who are often tasked with achieving greater than the minimum environmental performance standards.

Map E1-SG (also see Section 3.2) in the accompanying document ‘South Gloucestershire RERAS – Maps’ shows indicative heat demands in South Gloucestershire based on total gas consumption by Middle Layer Super Output Area (MSOA).

Map E3-SG shows the indicative residential only heat demand within South Gloucestershire by Lower Layer Super Output Areas (LSOA).

A higher resolution version of this map is contained in the accompanying document ‘South Gloucestershire RERAS – Maps’.

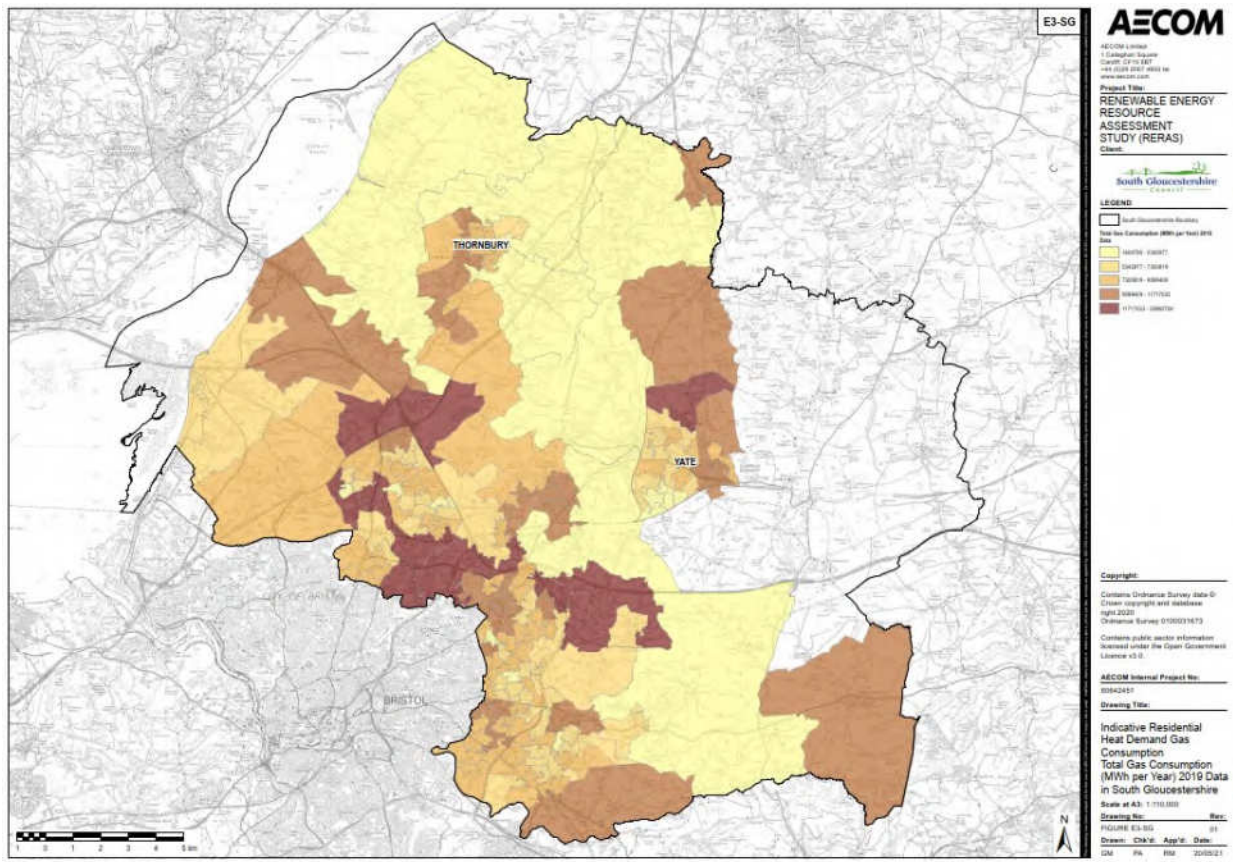

**Figure 60: E3-SG: Indicative Residential Heat Demand Total Gas Consumption (MWh per Year) 2019 Data for South Gloucestershire**

### 13.2.3 Map Locations of Strategic New Development Sites

This involves mapping the location of the strategic sites from the Development Plan using Geographic Information System (GIS). District Heat schemes are most cost-effective when installed as part of new development rather than retrofitting. At the time of writing the report, the new Local Plan for South Gloucestershire was under development and, as such, work to identify the location of potential strategic sites was ongoing. Relevant policies from the existing plan are included on the maps. Additionally, the heat mapping data can be used to assess development sites for the emerging plan for heat network potential.

### 13.2.4 Identifying Existing Energy Infrastructure and District Heating Networks

It is important to establish the nature of the existing energy infrastructure as it may provide opportunities for expanded connectivity or increased efficiency/ viability. There is an existing heat



network at the Frenchay Campus of the University of the West of England which is marked on the E4 map<sup>137</sup>.

Identification of current utilisation of renewable energy resources is covered by this RERAS which includes existing anaerobic digestions, landfill gas and energy from waste sites installations.

The utilisation of current waste heat sources can provide opportunities to improve fuel efficiency and secure CO<sub>2</sub> emission reductions. Extending existing infrastructure to additional users can increase the viability of a particular scheme.

### 13.2.5 Identifying Potential Renewable or Low Carbon Heat Sources

Currently, most of the existing heat networks across the UK are powered by natural gas. However, considering the Council's carbon-neutral ambition by 2030 and the fact that delivering the net zero target means transforming the gas sector, potential renewable or low carbon heat sources are included in the maps in this study section. Section 13.3.5 includes details of the heat sources, the data can be used to identify opportunities to foster renewable heat energy.

## 13.3 Mapping of Heat Demand and Viability Assessment

The heat demand of each building is illustrated on the maps by a circle. The circle size indicates the relative size of the heat load in question and allows for easily identifiable comparisons between different heat loads. The mapping informs a very high-level assessment of potential viability using an equation that links the value of potential energy sales with the length of pipe.

The radius of each circle is calculated based on the rule of thumb for the length of capital investment in a heat network and that which the revenue from heat sales to that load could support.

The equation used is:

$$R \approx \frac{AHL \times HP \times Y}{C}$$

Where:

- R = radius of circle, in metres
- AHL = annual heat demand, in kWh
- HP = price at which heat is sold, assumed to be £0.04/kWh
- Y = number of years of revenue assumed to be 10 years<sup>138</sup>
- C = estimate of the cost of installing heat pipe per m of a trench assumed to be £1000/m for this exercise

This methodology also provides an indication of the viability of connecting a heat load. If there are large gaps between circles, it suggests that connecting loads may not be viable. Conversely, if circles overlap, connecting them may be more viable.

### 13.3.1 Evaluation of District Heating Network Opportunities

The bringing together of various data layers described above informs the development of a 'Heat Opportunities Plan' shown in the E4 map. The development of the plan for South Gloucestershire Council allows for identifying clusters of sites with the potential to be technically feasible and economically viable for a heat network.

<sup>137</sup> <https://www.uwe.ac.uk/about/values-vision-strategy/sustainability/carbon-energy-and-water-management>

<sup>138</sup> In practice, a heat/electricity supply contract to an anchor load may last for 20 to 25 years, but the use of 10 years reflects the fact that the revenue over 25 years would roughly need to be twice the initial capital costs to cover the operation and maintenance costs for the network

**Policy Recommendation**

**Policy Reference: ES-PR-4 (Refer to Table 41 in Section 17)**

It is recommended that applications for renewable electricity generation, or development that is energy intensive and likely to have a surplus of heat, within 1km of a site with potential for seasonal energy storage (e.g. abandoned mine workings) should consider utilising such a facility.

**Policy Recommendation**

**Policy Reference: DH-PR-1 (Refer to Table 42 in Section 17)**

It is recommended that development proposals for dwellings, employment or depots for hosting transport fleets located within 0.5km of an existing renewable heat resources or renewable electricity generating installations should consider utilising such resources for heating, hot water and/or process use transport fuel.

SF

**Policy Recommendation**

**Policy Reference: DH-PR-2 (Refer to Table 42 in Section 17)**

It is recommended that proposals for development that will host heat intensive activities and are likely to generate excess heat (or power) should consider:

- c. Potential to be located within 0.5km of a heat demand cluster identified in the Heat Opportunities Map or other identified heat use;
- d. Enabling heat (power) off-take for supply for other / nearby uses and provide evidence of discussions with potential off-takers for the heat (or power).

**Policy Recommendation**

**Policy Reference: DH-PR-3 (Refer to Table 42 in Section 17)**

It is recommended that development proposals within 0.5km of an existing district heat network fed from a renewable (non-fossil fuel) source will be expected to connect where feasible and viable.

Figure 61 shows significant heat clusters and potential for heat networks in Yate, Thornbury, Filton and Downend. A higher resolution version of this map is contained in the accompanying document 'South Gloucestershire RERAS – Maps'.

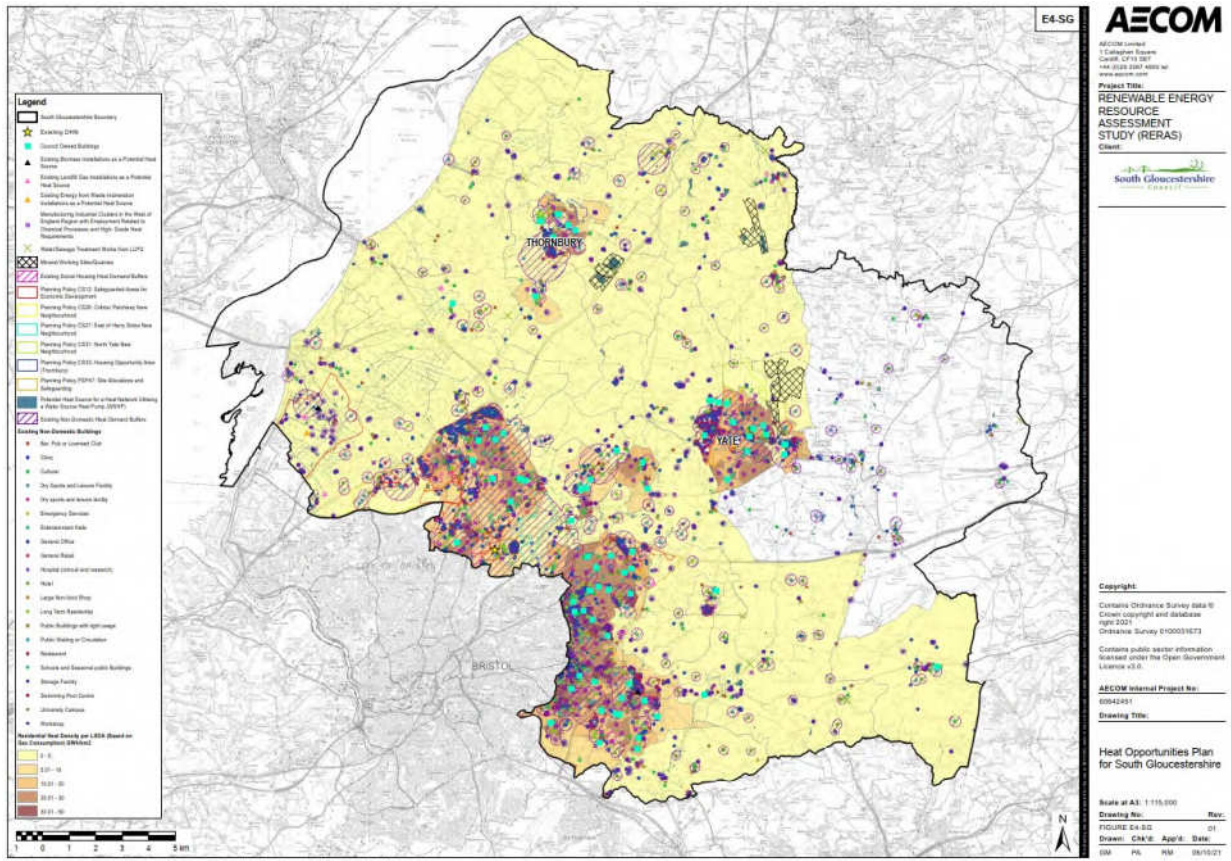

Figure 61: E4-SG: Heat Opportunities for South Gloucestershire Map

13.3.1.1 Oldbury Nuclear Power Station Site<sup>139</sup>

Oldbury nuclear power station is a decommissioned nuclear power station located on the south bank of the River Severn close to the village of Oldbury-on-Severn in South Gloucestershire, and the site presents an opportunity for renewable or low carbon energy generation which should be explored.



As evident from the E4 map, no heat demand cluster has been identified in the proximity of the site in this section of RERAS, and the closest existing cluster is in Thornbury. This rules out a heat network potential based on the existing buildings. Potential for future development sites can be considered via the method explained in this section.

There are a few manufacturing industrial clusters in the region with employment related to chemical processes and high-grade heat requirements; these sites can potentially use or utilise hydrogen. Furthermore, analysing W7 and S7 maps confirmed a potential solar PV and wind generation resource at the site. It should be noted the area of the nuclear building has been constrained on these maps because of the existing structure. However, W4 and S5 maps confirm sufficient wind speed for wind turbine installation and suitable land orientation and inclination for solar PV development. Therefore, it is recommended opportunities to use the site for renewable electricity generation should be explored with/ by the landowner. The electricity can be used to generate green hydrogen or exported to the grid.

<sup>139</sup> [https://assets.publishing.service.gov.uk/government/uploads/system/uploads/attachment\\_data/file/983583/Oldbury\\_Site\\_Environment\\_Management\\_Plan\\_Issue\\_14.pdf](https://assets.publishing.service.gov.uk/government/uploads/system/uploads/attachment_data/file/983583/Oldbury_Site_Environment_Management_Plan_Issue_14.pdf)

As explained earlier in this study, the results of this part of the assessment can be used to assist the Council in identifying or ranking potential development sites based on DHN potential. Therefore, this section describes the key factors considered when designing a network and area characteristics suitable for heat network development.

### 13.3.2 Heat Demand

As mentioned earlier, heat demands of the building are represented as circles with their size proportional to the size of the demand, and overlapping circles provide an indication of a potentially viable connection. The buildings are also colour coded based on the building use, and the council-owned buildings are flagged on the maps. Additionally, the E4 map illustrates the residential heat density and social housing heat demand in South Gloucestershire. When considering a potential strategic development site for a heat network, the Council can use the equation provided earlier in this section and the E4 map to do a very high-level assessment of the potential viability of the site. As an example, if the circle for a new site overlaps with heat circles from other existing buildings, it suggests that connecting the loads may be viable.

### 13.3.3 Route and Physical Barriers Consideration

The development of heat networks requires suitable routes to be identified to lay the pipework. The installation of pipes and associated equipment is expensive and disruptive, and therefore, the routing needs to be carefully considered to ensure the network is as efficient as possible so that the largest amount of heat possible is sold over the shortest length of pipework. Specific determining factors influencing the choice of network route include:

- The use of existing roads and pathways where public ownership enables development;
- The use of landscaped / pedestrian areas to reduce disruption to transport routes and allow lower cost installation;
- The use of minor roads where utility congestion may be less and where traffic disruption could be minimised;
- Aiming to find entrances to buildings which would allow pipework to be routed to existing plant rooms, based on information gathered, including site visits;
- Aiming to use minor roads where possible; and
- Provision for future expansion, e.g. designing the network to facilitate expansion or connection to other networks.

The installation of heat network pipes may cause significant disruption on transport routes and involve additional time delays, costs and risks. In general, the network layout should avoid using busy routes to minimise disruption to traffic during construction works. Many major roads have grass verges that could accommodate DH pipework, although these may be planted with trees that will need to be avoided. In places where major roads are excavated to install DH pipework, the oversizing of these pipes should be considered to future-proof the network against future expansion. Such future-proofing should, for example, consider the expansion of the network to serve more buildings and the connection to alternative heat sources.

Similar to the roads, railway lines, canals and rivers can also present a physical barrier to the location of a network route, as it is challenging to install pipes across them. Existing crossing points and bridges can provide opportunities for the network to cross these barriers. Location of the barriers should be in proximity or within the heat cluster area since a connection is technically and economically challenging and can only be justified if significant heat loads exist across the barrier (e.g. river). Therefore, the following data layers are included on the maps:

- Infrastructure (e.g. roads, railways etc.); and
- Surface water (e.g. canals, rivers etc.).

### 13.3.4 Land Ownership

Similar to electricity or gas infrastructure, when heat network pipes are routed through private land, wayleave and/or access rights need to be agreed upon with the landowners. There is no authorised

right of wayleave or easement for district heating infrastructure, unlike electricity or gas utilities providers. Whilst most such agreements are made voluntarily, where refused, a heat network developer is unable to apply for a compulsory right. As such, wherever possible, a network routes should follow public roads, minimising the need to negotiate and obtain permission from private landowners. GIS data of the maps heat network potential maps is provided to South Gloucestershire Council and can potentially be used to be viewed along with public-owned land data held by the Council.

### 13.3.5 Renewable or Low Carbon Energy Sources

As well as committed energy consumers, an energy network needs one or more sources of energy that offer the consumers an advantage over their business-as-usual energy supply arrangement. The energy source should also deliver environmental benefits; therefore, potential renewable or low carbon heat and, in some cases, electricity are included on the maps. When identifying suitable heat clusters or assessing future development sites for heat network potential, consideration should be given to the following sources that are included on the maps:

- Surface water that can potentially be used for a water source heat pump system.
- Manufacturing industrial clusters in the west of England region with employment related to chemical processes and high-grade heat requirements. These sites can be investigated further for any available waste heat.
- Existing anaerobic digesters, landfill gas and energy from waste sites installations. These sites may provide opportunities for expanded connectivity. There are existing locations in and near to South Gloucestershire which could act as a potential waste heat source, such as the Energy from Waste centres in Avonmouth and Severnside, the potential for which South Gloucestershire Council has investigated in partnership with Bristol City Council.
- Wind and Solar PV SAs identified in this RERAS that can be utilised to supply renewable electricity to a heat pump system or generate hydrogen (maps E5 and E6 in the accompanying document 'South Gloucestershire RERAS – maps' show the location of these SAs in conjunction with district heating network opportunities within South Gloucestershire').
- Mineral working sites/quarries. The mines that are included on the E4 map are based on the available data in the LLPG or South Gloucestershire's policies for active mines.
- However, when an underground mine is no longer in use, the pumps that were keeping them dry are often switched off. This results in the mine filling with water, which is heated and kept at a constant temperature throughout the year via geological processes. This water can be transferred through a pipe network and distributed through the district heat network using a heat exchanger.<sup>140</sup> Mine water heat is a low carbon heat source that could be considered for heat networks.
- The Coal Authority provides an interactive map viewer that allows for viewing selected coal mining information graphically. The database includes abandoned mines locations as well as mine water temperature maps. It should be noted that even with the higher water temperature mines, this does not necessarily mean the resource is useable because the water's depth, sustainable energy yield, and recharge potentials should be investigated further. A link to the dataset is provided in the footnote<sup>141</sup>.

#### Policy Recommendation

##### Policy Reference: DH-PR-4 (Refer to Table 42 in Section 17)

It is recommended that areas identified through the Local Plan for wind farms and solar PV farms are within 0.5km of an identified heat cluster, consideration is given to safeguarding these sites in order to provide electricity for powering heat pumps as part of a private wire / district heat network.

<sup>140</sup>Coal Authority – Geothermal energy from abandoned coal mines: <https://www2.groundstability.com/geothermal-energy-from-abandoned-coal-mines/>

<sup>141</sup>Coal Authority interactive map viewer: <https://mapapps2.bgs.ac.uk/coalauthority/home.html>

## 13.4 Summary and Conclusions

The high-level study undertaken allows for the identification of clusters of sites with the potential to be technically feasible and economically viable for a heat network. It also allows the Council to investigate future development sites for a heat network. However, the level of assessment is insufficient to propose targets for heat networks. However, it does indicate that there is potential for DHN schemes that require more in-depth analysis to identify which are financially viable. Appendix A provides further details regarding the support and funding schemes available for heat networks.

## 13.5 Next Steps

Once new development sites have been confirmed, the heat network map can be refined. The next steps for the Council in the development of heat networks in South Gloucestershire are:

- Identify appetite of anchor loads for the connection to a DHN;
- Survey of potential anchor loads to confirm compatibility with a heat network and age of the existing heating plant;
- Obtain current annual metre readings of anchor loads;
- Undertake a techno-economic viability assessment of potential clusters and network routes; and
- Network locations should then be safeguarded, and the planning process steered towards the connection of new buildings to the network.

## 14. Projected Energy Consumption in South Gloucestershire in 2030

This section of the study considers the future energy consumption of South Gloucestershire. To provide recommendations to aid the Council with its 2030 Climate Emergency aim, the 2030 future energy consumption has been assessed. Future consumption has then been compared with the potential installed capacity of the renewable and low carbon technologies discussed in Sections 4 to 10 to establish that the requirement for net zero carbon is achievable. A series of steps were undertaken to complete this task, as follows:

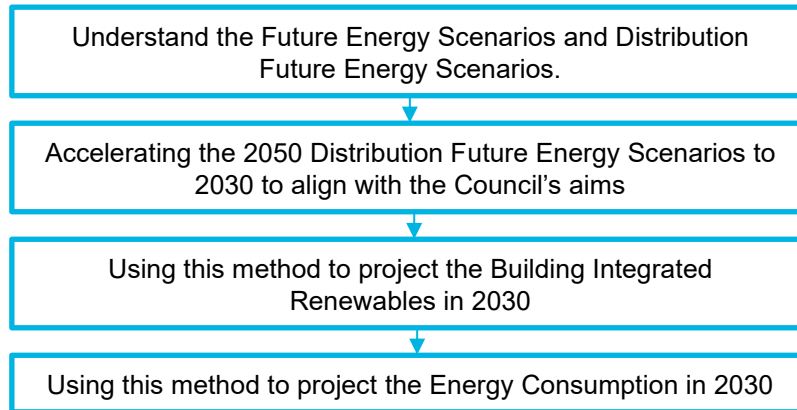

### 14.1 Understanding the Future Energy Scenarios and the Distribution Future Energy Scenarios

#### 14.1.1 Future Energy Scenarios

The National Grid Electricity Systems Operator's (ESO) produces Future Energy Scenarios (FES) annually<sup>142</sup>, containing in-depth analysis of different future scenarios in the energy system within the UK. The FES is used as a fundamental part of annual network planning and operability analysis. A description of the four scenarios and further details regarding them are provided in Appendix N.

Based AECOM's expertise, South Gloucestershire were advised to utilise the Consumer Transformation scenario in this study to maximise local solutions in achieving a net zero energy system.

The Consumer Transformation scenario assumes that net zero is met with measures that have a greater impact on consumers and is driven through consumer engagement. This scenario leads to considerable improvement to energy efficiencies and higher levels of renewable energy generation technologies integrated into homes.

Figure 62 shows the Consumer Transformation projected greenhouse gas emissions pathway for the UK.

<sup>142</sup> Future Energy Scenarios, National Grid ESO, July 2020; <https://www.nationalgrideso.com/document/173821/download>

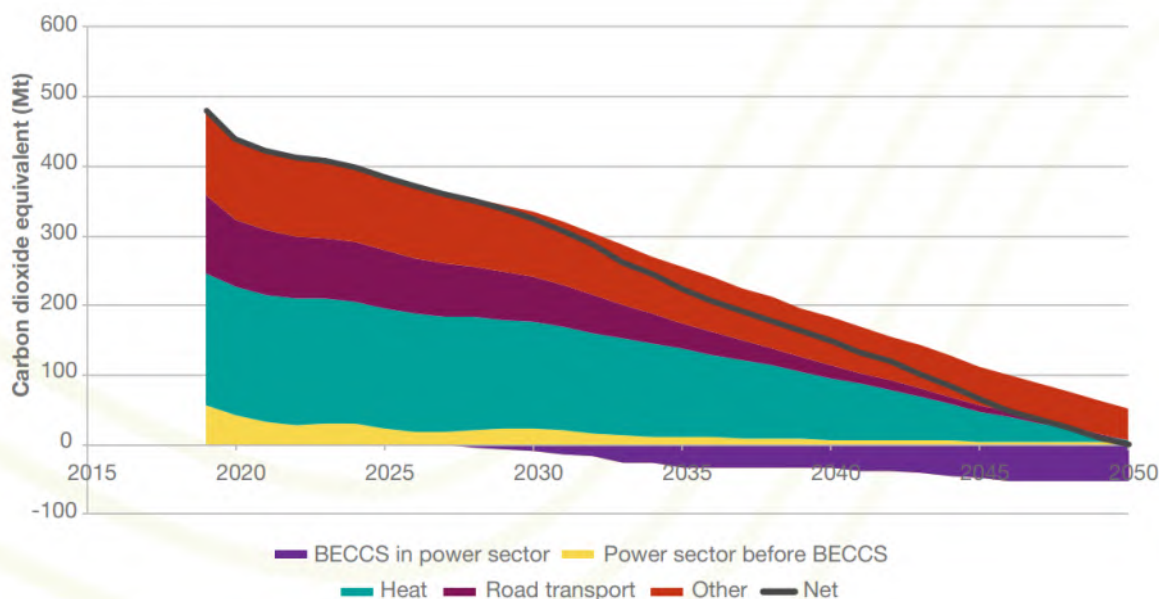

**Figure 62: UK Total Net Greenhouse Gas Emissions (Consumer Transformation)** <sup>143</sup>

The data shows the fundamental use of Bioenergy with Carbon Capture and Storage (BECCS) in achieving net zero emissions. BECCS is the combination of bioenergy with carbon capture, transportation and permanent storage to capture any CO<sub>2</sub> released during combustion. This is both a technically complex and costly process. The FES assumes that the greenhouse gases released in each scenario will be mainly offset by using BECCS. The use of BECCS to offset the projected additional greenhouse gas emissions is included in the FES at a national level. For South Gloucestershire, given the significant potential for renewable electricity generation from wind and solar PV and the relatively small amount of generation from bioenergy, it is unlikely that there will be a requirement for BECCS. In subsequent reviews of the Local Plan, depending upon progress towards its net zero aim, South Gloucestershire may wish to consider using BECCS to offset the residual emissions from the “Other” sector (Agriculture, Land Use and Land Use Change and Forestry (LULUCF), Waste, F-gases, Aviation and shipping) or remaining fossil fuel consumption locally.

**Policy Recommendation**

**Policy Reference: BM-PR-2 (Refer to Table 43 in Section 17)**

It is recommended that proposals for stand-alone electricity generation plant utilising biomass should be required to utilise a BECCS system and a whole life carbon benefit can be evidenced.

**14.1.2 Distribution Future Energy Scenarios**

Western Power Distribution (WPD) has used the National Grid ESO FES as a framework to make projections concerning changes in consumption, storage and distributed generation, including electrified transport and heat across South West England; these are the Distribution Future Energy Scenarios (DFES). As in the FES, the DFES are compliant with the 2050 UK net zero target, excluding the ‘Steady Progression’ scenario.

Alongside providing projections for renewable energy generation and energy consumption, the DFES also provides projections on the heating systems, uptake of heat pumps, and the transport system’s transformation.

<sup>143</sup> DFES 2020 Results and Assumptions Report, Figure 6: <https://www.regen.co.uk/wp-content/uploads/WPD-DFES-2020-technology-summary-report-South-West.pdf>



There will be an increase in the number of direct electric heating systems

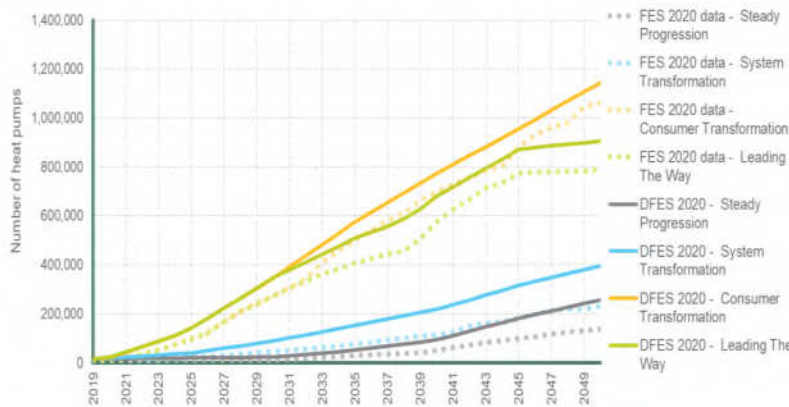

Table 28: Domestic Electric Heating by Scenario in the South West<sup>144</sup>

Data summary for direct electric heating in South West licence area:

Number of households (1,000s)	Baseline	2025	2030	2035	2040	2045	2050
Steady Progression	101	106	110	114	119	124	130
System Transformation	101	107	110	112	113	113	112
Consumer Transformation	101	107	109	110	110	108	107
Leading the Way	101	108	112	115	116	116	116

The baseline number of direct electric heating units (101,000) is based on analysis of domestic heating technology types from Energy Performance Certificate (EPC) data.



73% of homes will be served by a heat pump



Figure 63: Domestic Non-Hybrid Heat Pumps by Scenario in the South West<sup>145</sup>

Up to 270 times more electric vehicles

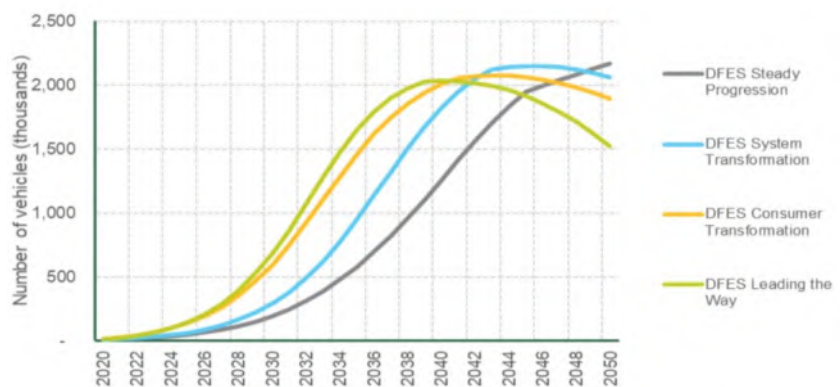

Figure 64: Battery Electric Vehicles by Scenario in the South West<sup>146</sup>

In Leading the Way, Consumer Transformation and System Transformation, the number of electric vehicles reduces from the late 2030s and mid 2040s respectively. This results from high levels of

<sup>144</sup> Distribution Future Energy Scenarios 2020, page 20, <https://www.regen.co.uk/wp-content/uploads/WPD-DFES-2020-technology-summary-report-South-West.pdf>

<sup>145</sup> Distribution Future Energy Scenarios 2020, page 17, <https://www.regen.co.uk/wp-content/uploads/WPD-DFES-2020-technology-summary-report-South-West.pdf>

<sup>146</sup> Distribution Future Energy Scenarios 2020, page 24, <https://www.regen.co.uk/wp-content/uploads/WPD-DFES-2020-technology-summary-report-South-West.pdf>

societal change resulting in high use of autonomous vehicles and public and active travel, resulting in many homes opting to have fewer cars or no car at all.

### 14.1.3 Guidance on Input to the Distribution Future Energy Scenarios

Local councils are consulted to provide input into the process of updating the WPD DFES once they have developed or updated their scenarios; this RERAS can be used to help with the process.

Regen's 2020 WPD DFES analysis and the RERAS use much of the same input data and methods to analyse the energy system. The DFES analysis may go deeper in terms of a geographic focus and granularity, but results can be aggregated up to a council level.

The main difference, however, is the starting point and the overall objective the analysis is looking to meet:

DFES provides a set of regional and sub-regional energy scenarios for the primary purpose of network planning, which are based on the National Grid ESO FES, other national or potentially devolved government scenarios. The DFES allows for a high degree of regional or devolved nation variation based on stakeholder input and supported by "bottom-up" evidence analysis but is still bounded within a national scenario framework and can be reconciled back to the national scenario. So, while the DFES should be strongly influenced and informed by stakeholder input, and regional evidence gathering, it does not claim to represent the full extent of local energy ambition and local objectives.

The RERAS starts from the basis of local energy objectives, not a national scenario. The RERAS, therefore, represents a much more local stakeholder view of the energy system, albeit with potentially strong input from energy networks.

The DFES starts from the basis of a national scenario that is modelled across one or multiple licence areas<sup>147</sup>. However, a RERAS starts from local energy objectives and can be more detailed and consider stakeholder input more thoroughly. Therefore, the RERAS projections and forecasts could be quite different from DFES results and national scenarios and serve a different purpose: to create momentum and impetus behind a locally defined energy future, a net zero action plan, and economic growth. The RERAS could be used to inform a Local Area Energy Plan (LAEP), which is an evidence-based plan which can enable the transition to a net zero-carbon energy system<sup>148</sup>. The production of a LAEP could provide a stable base for effective local action to reduce carbon emissions and potentially define specific proposals for local energy networks.

Incorporating RERAS results back into the DFES process would allow the District Network Operators (DNOs) to analyse the results within their network planning processes and compare and present the results against the national scenarios.

Incorporating the RERAS outputs within the DFES analysis would require some practical steps, all of which are surmountable:

- It would probably require the definition of a new (5th) DFES scenario as it would be difficult to reconcile the RERAS into one of the existing national scenarios;
- DFESs are updated annually, whereas a RERAS or LAEP is likely to be completed less regularly. Some means of updating or maintaining the RERAS would be required if the process was to be repeated annually. This is because the DFES process, being undertaken for multiple license areas at once, cannot always incorporate local energy objectives and stakeholder feedback;

<sup>147</sup> Distribution network operators (DNOs) licence areas. There are 14 licensed Distribution Network Operators (DNOs) in Britain and each is responsible for a regional distribution services area. DNO License Areas are sometimes referred to as GSP Groups and historically have also been known as Public Electricity Supplier (PES) regions.

<https://data.nationalgrideso.com/system/gis-boundaries-for-gb-dno-license-areas>

<sup>148</sup> <https://www.cse.org.uk/projects/view/1369>

- It is unlikely that the RERAS would cover an entire DNO licence area at any given time, a methodology would be needed to extend to the remaining licence area, or the approach could be to use the RERAS or LAEP inputs for a part of the licence area only.

## 14.2 Predicting 2030 Future Energy Consumption

The underlying scenario framework of the DFES and FES assumes a 2050 decarbonisation projection. This means that to ensure that the projections meet the Council’s 2030 decarbonisation aim, the 2050 projections and data points in the DFES and FES must be accelerated for South Gloucestershire from 2050 to 2030.

This acceleration was modelled such that the 2050 projections have been condensed to 2030. Therefore, it is assumed that in addition to the technology uptake rates, underlying assumptions on consumer behavior change, technology efficiencies, and energy efficiency rates have also been accelerated to meet local ambition. The only exclusion to this is the number of new dwellings. The number of new dwellings used within this assessment aligns with the value predicted within the DFES for 2030 (see Figure 65). The new housing requirement for South Gloucestershire is yet to be decided through the strategic planning process as part of the West of England Combined Authority (WECA) Spatial Development Strategy.

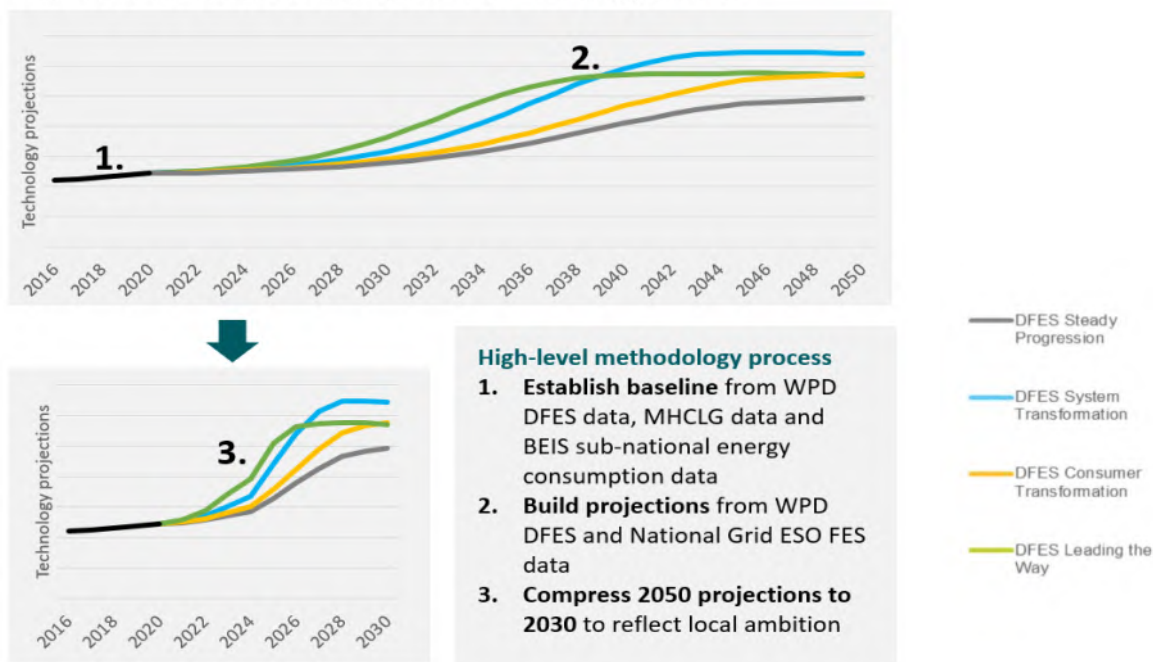

Figure 65: Homes Built Per Year in the South West<sup>149</sup>

Figure 66 shows the projection methodology process, the different colours represent different scenarios.

<sup>149</sup> DFES 2020 Results and Assumptions Report, Figure 6: <https://www.regen.co.uk/wp-content/uploads/WPD-DFES-2020-technology-summary-report-South-West.pdf>

**Illustrative scenario-based projection methodology process**



**Figure 66: Illustrative Scenario Based Projection Methodology Process**

**14.3 Building Integrated Renewables Projection**

Any renewable energy generation technology that is integrated as part of a building (domestic or non-domestic) is called a ‘building integrated renewable’. As the transition to renewable energy increases in line with the Consumer Transformation Scenario, the number of building integrated renewables will increase, and this requires consideration when projecting the future energy consumption.

**14.3.1 Calculation Method**

**14.3.1.1 Baseline**

The baseline of existing electrical energy projects was informed by Western Power Distribution’s (WPD) Distribution Future Energy Scenarios (DFES) data. Non-electrical heating technologies were evaluated from two sources; Ministry of Housing, Communities & Local Government (MHCLG) Energy Performance Certificate (EPC) data and English Housing Survey data, which provided a spatial baseline of heating technologies.

**14.3.1.2 Projection**

Projections of building integrated renewables in the region are estimated primarily using existing WPD DFES projections. The DFES projects the uptake of generation, storage and demand technologies connecting to the distribution electricity network to 2050 using the national Future Energy Scenarios (FES) as a framework.

For more information on the DFES and FES, see Section 14.1 and Appendix N.

**14.3.2 Building Integrated Renewable Energy Uptake in 2030**

**14.3.2.1 Domestic Thermal Technologies**

A breakdown of projections of domestic renewable heating technologies in South Gloucestershire in baseline year and 2030 is provided in Table 29.

**Table 29: Domestic Thermal Technologies Projections**

Technology	Number of Installations in 2019	Number of Installations in 2030
Hybrid Heat Pumps - Dwellings	0	11,659
Heat Pumps Systems - Dwellings	278	89,704
Direct Electric Heating Systems - Dwellings	4,758	5,903
Biofuel Systems - Dwellings <sup>150</sup>	0	768
Biomass Systems - Dwellings	138	232
Solar Thermal Systems - Dwellings	81	59

It is projected that by 2030, there will be a significant shift towards electric heating, particularly towards heat pump solutions. In relation to this, the Council's draft emerging planning policy states that non-renewable electric heating systems such as electric resistive heating would not be permitted in a new development except in certified Passivhaus developments. This aligns with national advice on the decarbonisation of heat and wider system-wide impacts.

#### 14.3.2.2 Non-Domestic Thermal Technologies

The FES data does not include projections of commercial and industrial thermal technologies. However, projections of total heat demand and the proportion of the heat that is supplied by electricity in these buildings is calculated.

Additionally, it was assumed that high-grade process heat requirements will be met by hydrogen in the commercial and industrial setting and therefore a projection of hydrogen electrolysis' portion of electricity consumption was calculated and shown in Section 12.

#### 14.3.2.3 Buildings Mounted Renewable Electricity Generators

Table 30 includes details of projection of micro building-mounted wind turbines and rooftop solar PV panels in South Gloucestershire.

**Table 30: Projection of Micro Building-Mounted Solar PV and Wind Installations**

Technology	Installed Capacity in 2019 (MWe)	Installed Capacity in 2030 (Including Existing) (MWe)
Onshore Wind <6kW <sup>151</sup>	0.017	0.088
PV-Commercial Rooftop (10kW - 1MW)	9.10	77.49
PV-Domestic Rooftop (<10kW)	12.88	150.82

## 14.4 Energy Consumption Projections

### 14.4.1 Calculation Method

#### 14.4.1.1 Baseline

The South Gloucestershire energy consumption baseline was informed by BEIS sub-national energy consumption statistics. This provided a sectoral energy baseline for different fuels for South Gloucestershire in the study and can be found in Section 3.

#### 14.4.1.2 Projection

Projections into the rate of change of energy consumption have been derived from National Grid ESO's Future Energy Scenarios. Therefore, the same scenario framework is used for both the technology projections and the energy consumption projections (see Figure 66).

<sup>150</sup> Biofuels such as biomethane are not considered as a separate renewable energy technology in this study, however DEFES includes projection of installation for these systems which is incorporated in RERAS.

<sup>151</sup> Small Scale Building Integrated

The ESO FES incorporates the key assumptions necessary to model future energy consumption projections within a scenario framework for different future pathways. For example, the scenarios incorporate assumptions on heating, including home efficiency improvements, technology efficiency improvements, and changes in consumer behaviour. It should be noted that achieving these will require policy interventions at the local and, in some cases, national level.

For more information on the DFES and FES, see Section 14.1.

#### 14.4.1.3 Industrial Process and Manufacturing Energy Consumption

Some energy consumption lies outside the scope of the National Grid ESO FES. In these cases, the Climate Change Committee's (CCC) Further Ambition scenario<sup>152</sup> projections on industry emissions are used. Relative to other sectors in the region, these emissions are relatively small.

#### 14.4.1.4 2030 Decarbonisation Aim Adjustment

As with the technology projections, the energy consumption projections have also been condensed from 2050 to 2030. Therefore, this assumes that underlying assumptions on consumer behaviour change, technology efficiencies, and energy efficiency rates have also been accelerated to meet local ambition. Appendix P includes details of the key data sources used to calculate future energy consumption and building integrated renewable technologies projections.

---

<sup>152</sup> <https://www.theccc.org.uk/wp-content/uploads/2019/05/Net-Zero-Technical-report-CCC.pdf>

## 14.5 2030 Energy Consumption in South Gloucestershire

Projected energy consumption in South Gloucestershire in 2030 is provided in Table 31.

**Table 31: Projected Energy Consumption (GWh) in South Gloucestershire in 2030**

Fuel Type	Use	Details	2030 Energy Consumption (GWh)
Fossil Fuels and Renewables Other Than Electricity	Heating	Domestic Buildings Fossil Fuels and Renewables Energy Consumption for Heating, Including Biomass (Energy Crops and Wood Fuel) and Biofuels	141.7
Electricity	Heating	Domestic Buildings Electricity Consumption for Heating e.g. Heat pumps, Direct Electric and Electrolysis of Hydrogen	390.3
Electricity	Non-Heating Electricity in Buildings	Domestic Buildings Non-Heating Electricity Consumption	243.9
Fossil Fuels and Renewables Other Than Electricity	Heating	Commercial and Industrial Buildings Fossil Fuels and Renewables Energy Consumption for Heating including Biomass (Energy Crops and Wood Fuel) and Biofuels	116.6
Electricity	Heating	Commercial and Industrial Buildings Electricity Consumption for Heating e.g. Heat pumps, Direct Electric and Electrolysis of Hydrogen	896.6
Electricity	Non-Heating Electricity in Buildings	Commercial and Industrial Buildings Non-Heating Electricity Consumption	738.6
Fossil Fuels and Renewables Other Than Electricity	Transport Sector	Transport Sector Other Fuels Consumption	263.8
Electricity	Transport Sector	Transport Sector Electricity Consumption	707.2
<b>Total Heat Demand (Including Electrical Heating Consumption)</b>			<b>1,545.3</b>
<b>Total Electricity Consumption (Including Electrical Heating Consumption and Transport Sector Electricity Consumption)</b>			<b>2,977.6</b>
<b>Total Transport Sector Energy Consumption</b>			<b>970.9</b>
<b>Total Energy Consumption</b>			<b>3,498.7</b>

Based on the results, there will be a total energy consumption of 3,498.7GWh in 2030; of this, domestic buildings' energy proportion accounts for 775.9GWh, C&I sector 1,751.8GWh and transport sector 970.9GWh of the total consumption.

The total electricity consumption across South Gloucestershire is projected to be 2,977.6GWh in 2030, including 1,286.9GWh of electric heating and 707.2GWh for electric vehicles.

The total heat consumption across South Gloucestershire is projected to be c1,545.3GWh in 2030. Of this, c1,286.9GWh will be met via electrical heating, and the remaining heat, which will be supplied by fuels other than electricity, is c258.3GWh.

To meet the additional heating demand, it is anticipated that fossil fuels may be required and thus will require offsetting in order to meet the net zero aim. The potential offsetting as a result of the use of these fossil fuels is outside the scope of the RERAS. The FES assumes that BECCS can be used as an offsetting method, see Section 14.1.1.

Figure 67 below illustrates the projected energy consumption across different sectors in South Gloucestershire in 2030.

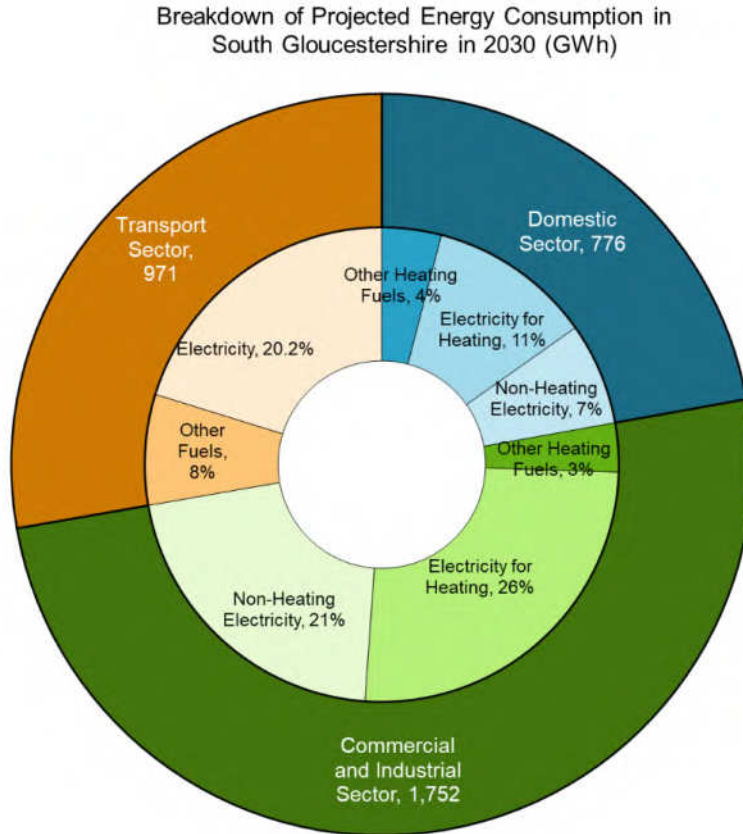

**Figure 67: Breakdown of Projected Energy Consumption (GWh) in South Gloucestershire in 2030**

Figure 68 below provides a comparison between the current and projected 2030 Energy



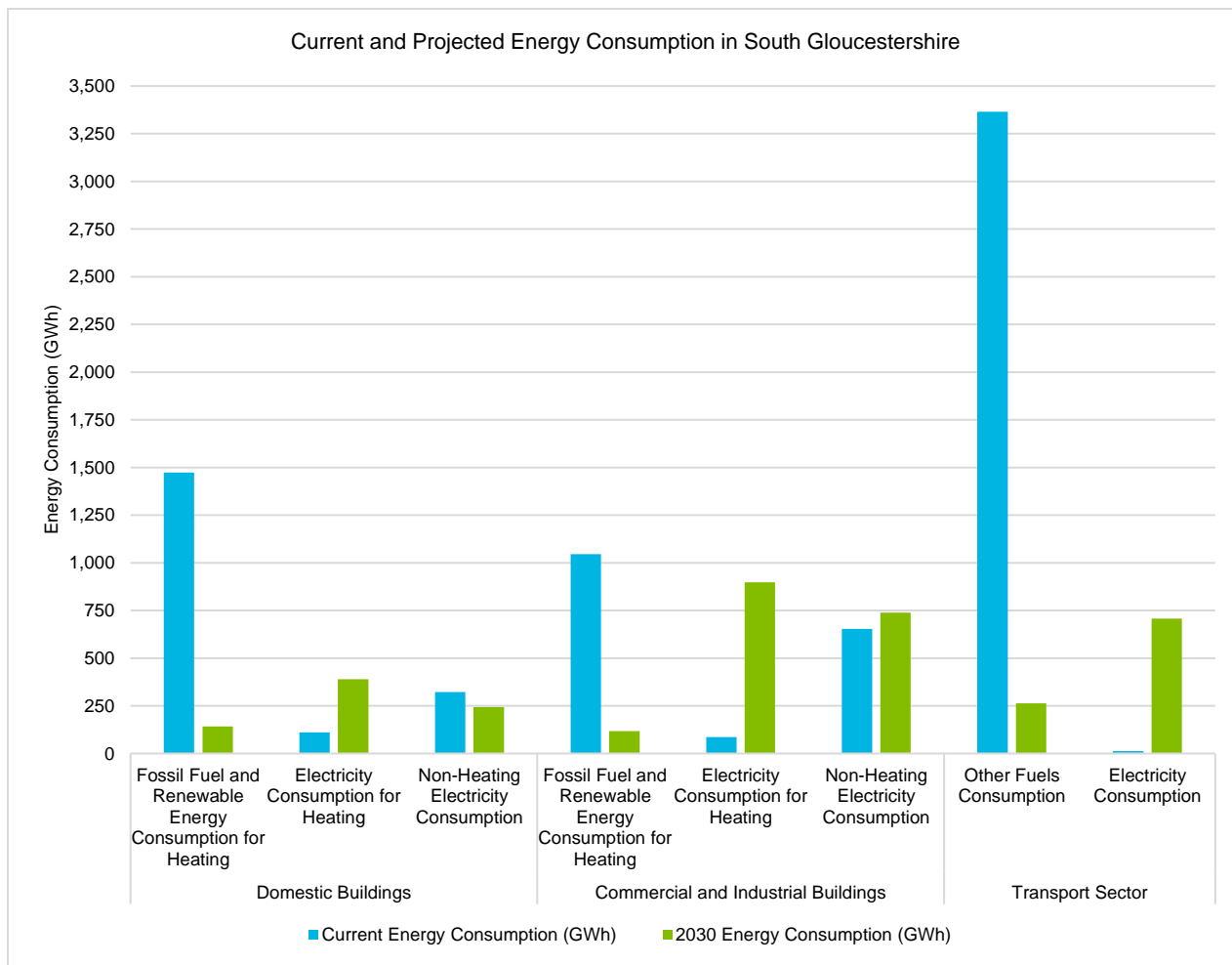

**Figure 68: Comparison of Current and 2030 Projected Energy Consumption in South Gloucestershire**

For domestic buildings, the use of fossil fuels is projected to be significantly lower in 2030, in fact figures and table in Appendix N only project a small amount of natural consumption in Industrial and Commercial sector only. Therefore, the green parts in this figure (for Fossil Fuel and Renewable Energy Consumption for Heating) are mainly for renewable energy. It should also be noted that under Consumer Transformation, heat pumps become the dominant heating technology hence the significant change in electricity for heating demand in comparison to moderate change in other renewables. The scenario assumes that the energy efficiency of buildings is improved through better insulation and by more energy efficient appliances. This reduces overall energy demand and will enhance the operation of heat pumps, when fitted.

The significant reduction in Transport energy demand relates to road transport and is due to a combination of electrification, automation and changing consumer behaviour<sup>153</sup>.

Commercial and industrial buildings follow a similar pattern in relation to heat pumps as domestic buildings, it also includes implantation of energy efficiency measures, but it should be noted that some industrial processes will not be fully decarbonised as mentioned above.

<sup>153</sup> National Grid ESO Future Energy Scenarios, July 2020, page 44 "The energy efficiency of vehicles varies greatly at point of use" <https://www.nationalgrideso.com/document/173821/download>

## 15. Identifying the Contributions of South Gloucestershire

### 15.1 Introduction

The previous sections of this study comprise an assessment of the potential renewable energy resource across South Gloucestershire, converted into installed capacities for each of the technologies. In doing this exercise, assumptions have been made about the technologies that might be utilised to meet the projected consumption in 2030. This section looks to combine outputs of the resource assessment, technology assumptions and future demand projections to provide some scenarios for South Gloucestershire Council to meet its renewable energy generation aims. In order to integrate these sections, a series of steps need to be followed:

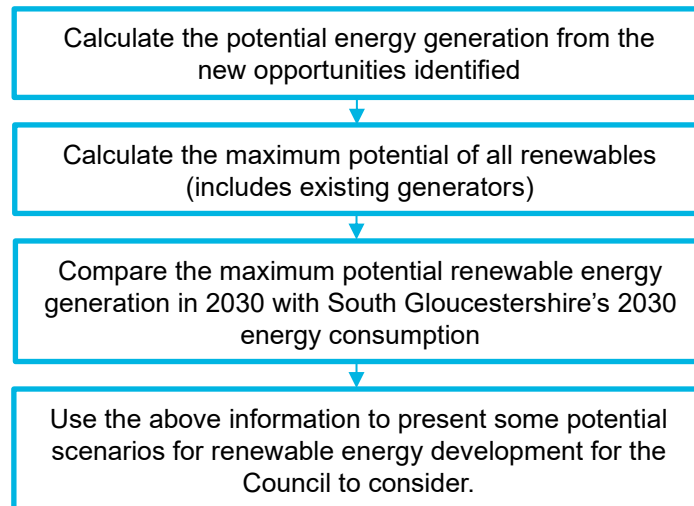

#### 15.1.1 Calculating Energy from Installed Capacity

The area-wide resource assessment results indicate the potential installed capacity for different technologies (in MW) that the available resource can support. A well-established and straightforward way of estimating how much energy the potential capacity might generate is to use capacity factors (as load factors).

These factors, which vary by technology, measure how much energy a generating station will typically produce in a year for any given installed capacity.

This reflects the fact that the installed capacity is a measure of the maximum amount of power or heat that a generating station can produce at any given moment. However, for reasons to do with either fuel availability, the need for maintenance downtime, or a heat-generating plant, a lack of heat demand at certain times of day or year, the capacity factor is always less than 1.

The annual energy output for each technology can be calculated by multiplying the installed capacity by its capacity factor and the number of hours in a year (8,760).

A summary of the different capacity factors for different technologies is given in Table 32 and Appendix O includes sources of the data for each renewable technology capacity factor.

**Table 32: Capacity Factors for Renewable and Low and Zero Carbon Technologies**

Technology	Capacity Factor <sup>154</sup>
Onshore Wind	0.25
Biomass (Electricity)	0.75
Biomass (Heat)	0.40
Hydropower	0.29
Energy from Waste (Electricity)	0.90
Energy from Waste (Heat)	0.50
Landfill Gas (Electricity)	0.46
Landfill Gas (Heat)	0.30
Anaerobic Digestion Utilising including Food Waste, Animal Slurry, Poultry Litter, Sewage Sludge and Sewage Gas. (AD with CHP)	0.43
Anaerobic Digestion Utilising Food Waste, Animal Slurry, Poultry Litter, Sewage Sludge and Sewage Gas. (Heat)	0.5
Solar Farm	0.11
Domestic and Non-Domestic Renewable Electricity Technologies Such as Rooftop Solar PV (electricity)	0.10
Domestic and Non-Domestic Renewable Thermal Technologies (Thermal)	0.20

## 15.2 Maximum Theoretical Potential of New Renewable Energy Solutions

The maximum theoretical new potential renewable electrical and thermal installed capacity across South Gloucestershire, excluding that which is already installed, was calculated as circa 11,785MWe and circa 3.06MWt for 2030.

The figures above exclude building integrated biomass and biofuel. DFES makes a projection about how much biomass and biofuel will be used in South Gloucestershire in 2030. The figure assumed is lower than the identified available resource, so we have assumed that only the DFES amount is supplied from local biomass sources and is represented as a 'consumption' figure in Table 33 (as opposed to an installed capacity/ generation figure).

The maximum theoretical new potential renewable electrical and thermal generation across South Gloucestershire, excluding that which is already installed, was calculated as circa 11,890MWhe and circa 53.63MWht for 2030.

Electric heating installations are not included within this section as they are based on the DFES condensed projection and are therefore presented within the projected total electric consumption figures; see Section 14.5, which shows a 2030 energy consumption of 390.3GWh and 896.6GWh for domestic building electricity consumption and commercial and industrial building electricity consumption for heating respectively.

The total installed electrical capacity is dominated by potential solar and wind power with contributions from energy from waste, building integrated technologies and hydropower sites. These figures represent the theoretical maximum potential resource.

Total potential heating technologies across South Gloucestershire in 2030 will be dominated by electric heating (whether this is in the form of direct electric heat pumps and/or hydrogen generated by electrolysis (mainly in the C&I sector). It should be noted that, due to hydrogen being an up-and-coming technology, it will be challenging to introduce the necessary infrastructure for large scale deployment by 2030 as it will be to retrofit the majority of homes with heat pumps and replace the majority of fossil fuelled vehicles with electric versions. It could be, due to the compressed timescales of South Gloucestershire's delivery aims, that the nature of the Council's decarbonisation is different to DFES projections e.g. hydrogen consumption is replaced by different electrically fed solutions or

<sup>154</sup> Refer to Appendix O for sources of the data.

other energy low carbon carriers such as biogas. Table 33 shows that there will be additional potential from other renewable heating technologies such as Energy from Waste (EfW). The figures shown in the table use the DFES projections for building integrated systems and the resource identified within this study for wind and solar PV developments<sup>155</sup>.

**Table 33: Maximum Theoretical Potential Renewable Energy Resource and Generation in South Gloucestershire in 2030 (Excluding Existing Installations and Heat Delivered via Electric Heating Systems).**

Resource	Potential Installed Capacity (Excluding Existing)		Potential Maximum Delivered Energy GWh	
	Electricity (MWe)	Thermal (MWt)	Electricity (GWhe)	Thermal (GWht)
Wind (500kW, 1.0MW and 2.5MW Turbines) <sup>156</sup>	392.49	-	854.31	-
Solar PV Farms	11,184.20	-	10,847.96	-
Other (including food waste, animal slurry, poultry litter and sewage sludge. AD with CHP)	1.78	2.90	6.77	12.70
Projected Building Integrated Wind (<6kW) Turbines in 2030	0.07	-	0.06	-
Projected PV-Commercial Rooftop (10kW - 1MW) in 2030	68.39	-	59.91	-
Projected PV-Domestic Rooftop (<10kW) in 2030	137.94	-	120.84	-
Projected biomass consumption by building integrated biomass boilers in 2030 (domestic)	-	-	-	5.610
Projected biofuel consumption by building integrated biofuel boiler in 2030 (domestic)	-	-	-	35.04
Projected heat delivered by solar thermal in 2030 (domestic)	-	0.16	-	0.28
<b>Total</b>	<b>11,784.88</b>	<b>3.06</b>	<b>11,889.84</b>	<b>53.63</b>

### 15.3 South Gloucestershire Maximum Potential Renewable Energy Generation and 2030 Energy Consumption

Table 34 shows the theoretical maximum potential renewable electrical and thermal generation across South Gloucestershire, including that which is already installed<sup>157</sup>. The electric heating installations are not included in this section as they are considered in total electricity consumption figures.

<sup>155</sup> In this RERAS, 45.11GWht of biomass resource has been identified (see Section8) however, the above figures only contain uptake based on the DFES and therefore these have not been included in the table.

<sup>156</sup> The potential from 1.0MW and 2.5MW Search Areas cannot be added together as some of the areas overlap. The maximum capacity in this table is taken from 1.0MW Search Areas plus and additional non-overlapping 2.5MW search areas.

<sup>157</sup> In this RERS, 45.11GWht of biomass resource has been identified (see Section8) however, the above figures only contain uptake based on the DFES and therefore these have not been included in the table.

**Table 34: Maximum Potential Renewable Energy Generation in South Gloucestershire in 2030 (Excluding Heat Delivered via Electric Heating Systems)**

Resource	Existing Installed Capacity		Maximum Installed Capacity from New Installations		Potential Maximum Delivered Energy GWh	
	Electricity (MWe)	Thermal (MWt)	Electricity (MWe)	Thermal (MWt)	Electricity (GWhe)	Thermal (GWht)
Energy from Waste	9.67	0.35	0.00	0.00	76.24	42.35
Hydropower	0.001	-	0.00	-	0.003	-
Landfill Gas	9.76	-	-	0.00	39.55	-
Large scale wind <sup>158</sup>	8.2	-	392.49	-	872.14	-
Solar PV Farms	124.40	-	11,184.20	-	10,968.62	-
Other (including biomass, food waste, animal slurry, poultry litter and sewage sludge. AD with CHP)	9.28	-	1.78	2.90	64.66	12.70
Projected Building Integrated Wind (<6kW) Turbines	0.017	-	0.07	-	0.08	-
Projected PV-Commercial Rooftop (10kW - 1MW)	9.10	-	68.39	-	67.88	-
Projected PV-Domestic Rooftop (<10kW)	12.88	-	137.94	-	132.12	-
Projected biomass consumption by building integrated biomass boilers in 2030 (domestic)	-	-	-	-	-	5.610
Projected biofuel consumption by building integrated biofuel boiler in 2030 (domestic)	-	-	-	-	-	35.04
Projected heat delivered by solar thermal in 2030 (domestic)	-	-	-	0.16	-	0.28
Non-domestic renewable thermal technologies other than heat pumps <sup>159</sup>	-	9.8	-	-	-	17.14
<b>Total</b>					<b>12,221.3</b>	<b>113.12</b>

The total potential electrical capacity is dominated by potential solar and wind power with contributions from energy from waste, building integrated technologies, biomass, anaerobic digestion plants and hydropower sites. These figures represent a theoretical maximum potential resource.

The data shows that the theoretical maximum potential renewable electricity generation in South Gloucestershire in 2030 is circa 12,221.3GWh. Therefore, there would be more than enough resource to meet the 2,977GWh projected electricity consumption in 2030 (see Section 14.2).

<sup>158</sup> The potential from 1.0MW and 2.5MW search areas cannot be added together as some of the areas overlap. The maximum capacity in this table is taken from 1.0MW search areas plus and additional non-overlapping 2.5MW search areas.

<sup>159</sup> It has been assumed the majority of new renewable heat installations in non-domestic buildings will be of electric heating. High-grade heat requirements will be met by hydrogen in the C&I setting and therefore hydrogen electrolysis's portion of electricity demand is also calculated and included.

The total 2030 electricity consumption includes electrical heating (including heat pumps), transport sector electricity consumption, electricity consumption for uses other than heating, and electricity consumption for hydrogen electrolysis.

As the potential renewable electricity generation in South Gloucestershire is considerably higher than required to meet the projected 2030 consumption of 2,977GWh, there is flexibility for the Council to apply other constraints and additional considerations to refine the SAs through the Local Plan process. Data regarding potential other constraints and their impact upon theoretical maximum potential renewable energy generation can be found in Appendix E and Appendix H.

The theoretical maximum potential from renewable heating technologies is projected to be 113.12GWh in 2030. Therefore, it is concluded that there will only be enough resource to meet 43.8% of the projected 258GWh heat consumption (see Section 14.4) by fuels other than electricity.

The renewable heating technologies include biomass (energy crops and wood fuel) anaerobic digestion with CHP (food waste, animal slurry, poultry litter and sewage sludge) and solar thermal.

The maximum potential for renewable energy resource is presented in this section however, a 100% uptake of the potential installed capacity identified through the study, particularly for solar PV and wind, is extremely ambitious and unlikely to be achievable. It would also be highly undesirable for such a large proportion of South Gloucestershire to be developed for energy generation. Moreover, there is insufficient demand and infrastructure to take the power that would be generated by such an approach and hence the majority of the developments would become unviable as projects. Appendix S includes further details regarding this option.

#### 15.4 Scenarios for a Carbon Neutral South Gloucestershire in 2030

This RERAS has utilised the Distribution Future Energy Scenarios (DFES) and Future Energy Scenarios (FES), accelerated from 2050 to 2030, to project the electricity and heat consumption in South Gloucestershire in 2030. These scenarios should be monitored annually against actual performance in order that the Council can feed into future iterations of DFES, and to achieve progressively better alignment with its aims. For more information on the FES and DFES; see Section 14.1 and for guidance on incorporating RERAS results into the DFES process, see Section 14.1.3.

At the moment, the decarbonisation scenarios presented reflect, as accurately as possible, the evidence gathered i.e. the future demand for electricity will increase significantly and the only resource and technologies likely to be able to meet the demand in 2030 is larger scale wind farms and solar PV farms. This study reveals the key policy considerations to be how much local generation is acceptable and where to locate it. The evidence and recommendations presented here inform those considerations, including for public consultation and community engagement at a later stage through the Local Plan process. Community Engagement is considered in Section 16, and recommendations for policy provided in Section 17. We have presented three decarbonisation scenarios below to inform the discussion and how each of the scenarios relate to net zero carbon in South Gloucestershire in 2030.

It should be noted that in all three of the scenarios, it was assumed that the assumptions set out for 2050 in DFES Consumer Transformation scenario are met in 2030, this includes the number of heat pumps installed and changes to the heating systems, energy efficiency upgrades in buildings, installation of building integrated renewables and the transformation of the transport systems (e.g. electric vehicles uptake). These projections are likely to require policy interventions at the local and national levels to be met.

#### Policy Recommendation

##### Policy Reference: SC-PR-1 (Refer to Table 38 in Section 17)

It is recommended the three NZC calculations are presented as scenarios, for information only.

## Policy Recommendation

### Policy Reference: SC-PR-2 (Refer to Table 38 in Section 17)

It is recommended that the Council aims to maximise the potential for the generation and supply of renewable and low and zero carbon electricity and heat.

#### 1. Meet the DFES defined efficiency and renewable electricity contribution only

In this scenario, it is assumed that the Consumer Transformation 2050 projections (see Appendix N) set out in the DFES for South Gloucestershire are met in 2030. The energy generation produced by renewables is equivalent to South Gloucestershire's share of grid renewable electricity in 2050 to meet zero carbon. This scenario results in South Gloucestershire greening its share of the grid electricity by 2030. Once other areas 'catch-up' in 2050 as per DFES, South Gloucestershire electricity consumption will become net zero. This scenario includes the assumptions and projections set out in the DFES Consumer Transformation scenario, including the number of heat pumps installed and changes to the heating systems, energy efficiency upgrades in buildings, installation of building integrated and standalone renewables (e.g. solar PV and wind farms) and the transformation of the transport systems (e.g. electric vehicles uptake). This scenario and the following two scenarios are likely to require policy interventions at the local and national levels.

This scenario means that South Gloucestershire would only 'green' the proportion of the grid identified by the DFES.

#### 2. Meet the equivalent of 33% of the electricity demand in South Gloucestershire by 2030 and set out a pathway and targets to ensure the equivalent of 100% of the demand is met by 2050.

This scenario acts as a steppingstone between scenarios 1 and 3 and assumes that 33% of the electricity demand in South Gloucestershire in 2030 will be met by installing additional wind and solar developments in some of the Search Areas identified in this study. As there are certain assumptions outlined in the DFES (such as uptake of heat pumps and electric vehicles) that have been condensed to 2030 in this study, this option provides insurance in case these are not met as a higher proportion of the demand will be met by local renewables in comparison to the scenario one projection. This scenario also includes the assumptions set out in the DFES Consumer Transformation scenario, including the number of heat pumps installed and changes to the heating systems, energy efficiency upgrades in buildings, installation of building integrated renewables and the transformation of the transport systems (e.g. electric vehicles uptake).

The renewable energy generation can then be assessed every 10 years, and the aim increased to ensure the equivalent of 66% of South Gloucestershire's demand can be met by 2040 and 100% by 2050. By 2030, this approach also meets the equivalent of the proportion of the grid identified in the DFES as South Gloucestershire's contribution to UK zero carbon in 2050.

#### 3. Meet the 2030 electricity demand in South Gloucestershire from generation located within South Gloucestershire

This scenario assumes that the 2030 electricity demand in South Gloucestershire will be met by installing additional wind and solar developments in some of the Search Areas identified in this study. The demand could be met through a varying combination of wind development and solar development, promoted through Local Plan policies and strategy. This scenario also includes the assumptions set out in the DFES Consumer Transformation scenario, including the number of heat pumps installed and changes to the heating systems, energy efficiency upgrades in buildings, installation of building integrated renewables and the transformation of the transport systems (e.g. electric vehicles uptake).

Below, in Figure 69, is a bar chart that provides a visual representation of the renewable electricity generation in 2030 for each scenario as well as South Gloucestershire's electricity consumption in 2030.

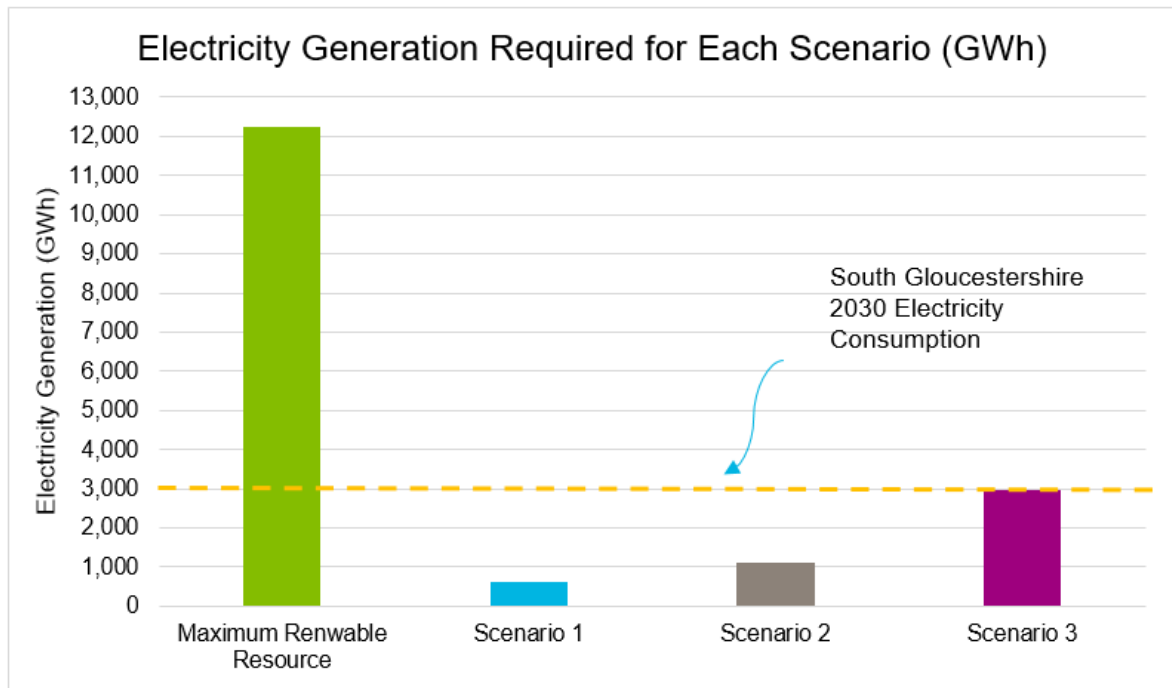

**Figure 69: Comparison of Energy Generation Required for Each Scenario**

The three scenarios are explained in further detail below.



Scenario 1 - Meeting the Distribution Future Energy Scenario Projection by 2030

In this scenario, it is assumed that the Consumer Transformation 2050 projections (see Appendix N) set out in the DFES for South Gloucestershire are met in 2030. The energy generation produced by renewables is equivalent to South Gloucestershire's share of grid renewable electricity in 2050 to meet zero carbon. This scenario results in South Gloucestershire greening its share of the grid electricity by 2030. Once other areas 'catch-up' in 2050 as per DFES, South Gloucestershire electricity consumption will become net zero. This scenario includes the assumptions set out in the DFES Consumer Transformation scenario, including the number of heat pumps installed and changes to the heating systems, energy efficiency upgrades in buildings, installation of building integrated and standalone renewables (e.g. solar PV and wind farms) and the transformation of the transport systems (e.g. electric vehicles uptake). These projections are likely to require policy interventions at the local and national levels to be met.

This scenario results in South Gloucestershire greening its share of the grid electricity in 2030, but it should be noted that although South Gloucestershire's proportion of the grid will be green by 2030, the rest of the UK will not have achieved greening their proportion of the grid yet.

The breakdown of the DFES projections can be found in Appendix R.



Scenario 1 assumes that majority of homes are primarily heated by heat pumps (circa 73% of homes in the South West as per the DFES) and there will be a 24% increase in number of dwellings with direct electric heating in South Gloucestershire.



Scenario 1 assumes that there will be circa 270 times more electric vehicles than in 2020, as per the DFES<sup>160</sup>.



The DFES requires approximately four new 5MW wind developments and two new 50MW solar developments in South Gloucestershire to meet the large scale wind and solar projections.



Meeting the DFES projections in 2030 would generate enough renewable electricity to cover 20.3% of South Gloucestershire's 2030 Consumption.

This scenario means that South Gloucestershire would only 'green' the proportion of the grid identified by the DFES.

Scenario 1 Electricity Generation VS South Gloucestershire 2030 Demand



2030 Energy Generation by Technology Breakdown in Scenario 1 - GWh

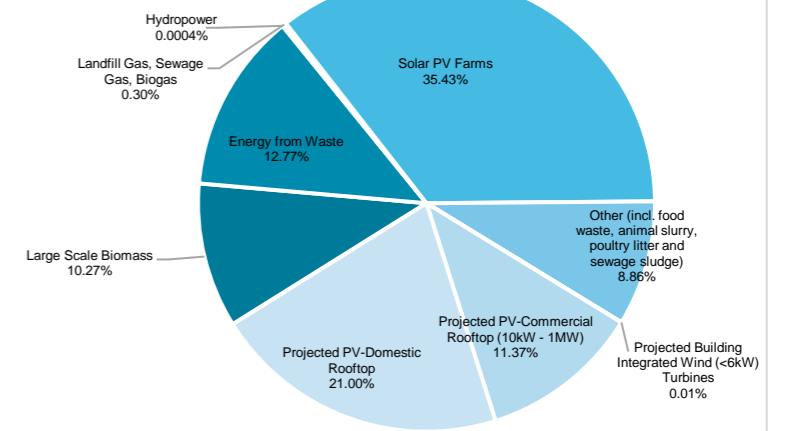

Figure 70: Electricity Generation Comparison of Scenario 1 and South Gloucestershire's 2030 Consumption

Figure 71: Technology Breakdown of Scenario 1 by GWh



Scenario 1 requires 2 additional 50MW solar farms and 4 additional 5MW wind farms

Figure 72: Pictogram of Number of Additional 50MW Solar Farms and 5MW Wind Farms Required in Scenario 1<sup>161</sup>

Table 35: DFES Technology Projection Breakdown (See Appendix R for More Details)

Technology	2050 DFES Projections	2030 Projections for South Gloucestershire	Total Generation Required to meet 2030 DFES Projection (MWh/annum)	Additional Capacity required to meet DFES (MWe)	Additional Generation required to meet DFES (MWh)
Onshore Wind	27.23	27.23	52,925.3	19.04	36,772.28
Ground Mounted Solar	218.1	218.1	211,572.15	93.73	90,912.10
Building Integrated Wind	0.09	0.09	77.38	0.07	62.49
Building Integrated Solar - Rooftop	259.7	228.3 <sup>162</sup>	199995.6	206.32	180739.4
Landfill Gas, Sewage Gas, Biogas	0.44	0.44	1,767.64	-9.32	-37,778.46
Hydropower	0.001	0.001	2.50	0.00	0.00
Large Scale Biomass	9.278	9.278	61,361.49	0.00	0.00
Waste Incineration (EfW)	9.670	9.670	76,238.28	0.00	0.00

<sup>160</sup> 7,000 EVs in baseline year and 1,894,000 EVs in 2030 in the South West licence area in Consumer Transformation scenario.

<https://www.regen.co.uk/wp-content/uploads/WPD-DFES-2020-technology-summary-report-South-West.pdf>

<sup>161</sup> Each solar panel icon is equivalent to one 50MW solar farm. Each wind turbine icon is equivalent to one 5MW wind farm

<sup>162</sup> The building integrated solar 2030 figure is lower than the DFES 2050 projection as number of new dwellings used within this assessment aligns with the value predicted within the DFES for 2030 not 2050.

**Scenario 2 – Meet 33% of South Gloucestershire’s Consumption by 2030**

This scenario acts as a stepping-stone between scenarios 1 and 3.

It is still assumed that the DFES projections for South Gloucestershire, accelerated to 2030 for this study, would be installed, and the additional generation would be covered through the wind and solar Search Areas identified in this study. However, as specific projections outlined in the DFES (such as transport transformation and heating systems uptake) have been condensed to 2030 in this study, this option provides insurance if these are not met.

A 100% uptake of the available wind installations (1.0 MW and 2.5MW SAs) was assumed, with the additional required generation being met by the solar PV farms. This combination is not mandatory, and a different ratio of wind farms to solar PV farms could be used to meet the required generation.

In this scenario, a pathway can be produced, which includes a series of renewable energy generation aims that can be assessed and updated on a 10-year basis to ensure South Gloucestershire can achieve net zero carbon by 2050. The suggested pathway is as follows:

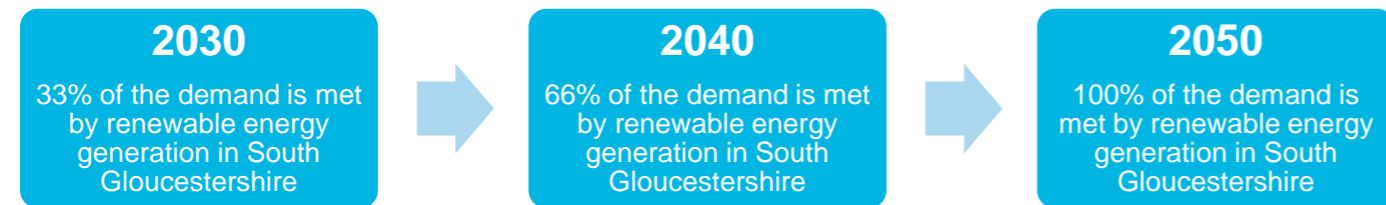

*Scenario 2 assumes that majority of homes are primarily heated by heat pumps (circa 73% of homes in the South West as per the DFES) and there will be a 24% increase in number of dwellings with direct electric heating in South Gloucestershire.*

*Scenario 2 assumes that there will be circa 270 times more electric vehicles than in 2020 in the South West of England, as per the DFES<sup>163</sup>.*

*Scenario 2 would require six new 50MW solar farms\* and twenty-two new 5MW wind farms in South Gloucestershire.*

\*Assuming a take up of 100% of the wind resource (1.0MW and 2.5MW SAs) identified in this study and meeting the remaining demand with solar PV and existing generation.

This scenario requires consideration by the Council and communities, industry and other stakeholders as to the appropriate renewable energy generation mix. This could include decisions relating to the planning balance and potential additional constraints within South Gloucestershire.

<sup>163</sup> 7,000 EVs in baseline year and 1,894,000 EVs in 2030 in the South West licence area in Consumer Transformation scenario. <https://www.regen.co.uk/wp-content/uploads/WPD-DFES-2020-technology-summary-report-South-West.pdf>

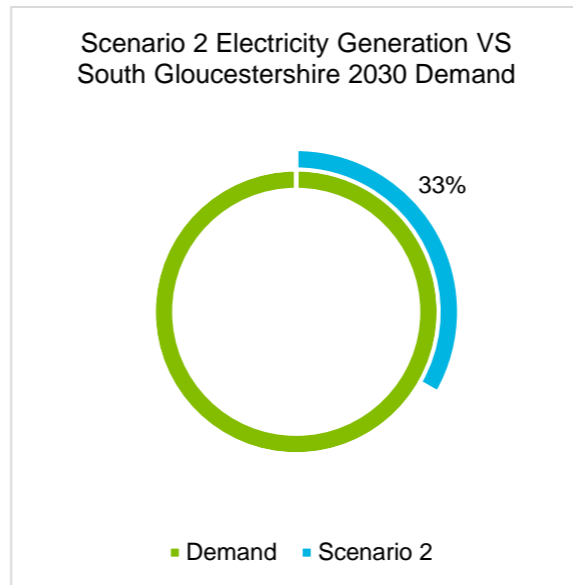

Figure 73: Electricity Generation Comparison of Scenario 2 and South Gloucestershire's 2030 Consumption

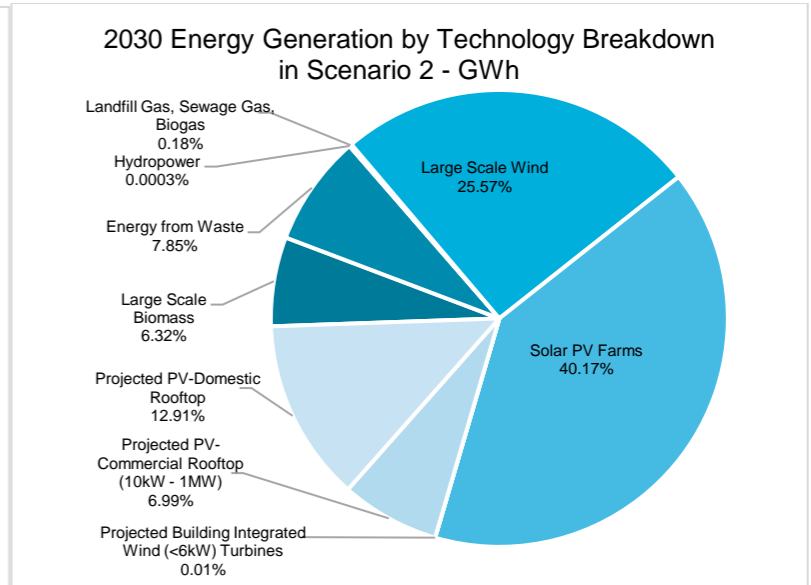

Figure 74: Technology Breakdown of Scenario 2 by GWh

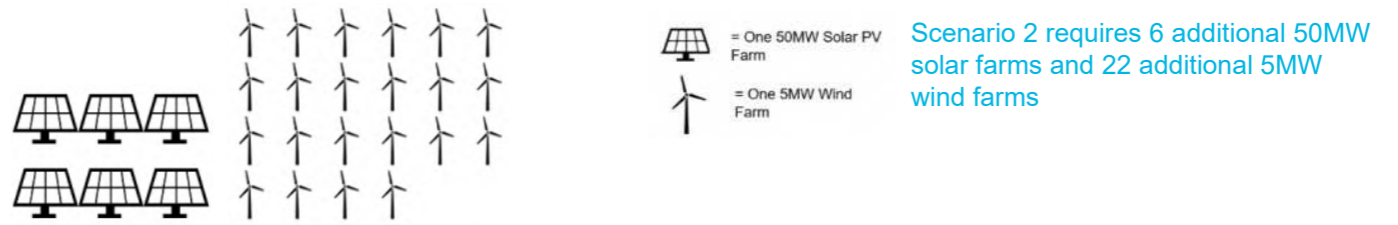

Figure 75: Pictogram of Number of Additional 50MW Solar Farms and 5MW Wind Farms Required in Scenario 2<sup>164</sup>

Table 36: Electricity Generation Potential from New Wind and Solar Farms in Scenario 2<sup>165</sup>

	Wind Farms				Solar PV			
	Assumed Up-take %	Installed Capacity (MW)	Projected Electricity Generation from Wind (GWh)	Estimated Number of New Wind Farms to be Built until 2030**	Assumed Up-take %	New Installed Capacity (MW)	Projected Electricity Generation from Solar PV (GWh)	Estimated Number of New Solar PV Farms to be Built Until 2030***
Total New Potential based on an assumed up-take	100%	106.0	232.1	22	2.5%	280	269.4	6

\*\*Assuming 5MW per site (eq. 0.625 km<sup>2</sup>)      \*\*\* Assuming 50MW per site (eq.1.2 km<sup>2</sup>)

<sup>164</sup> Each solar panel icon is equivalent to one 50MW solar farm. Each wind turbine icon is equivalent to one 5MW wind farm

<sup>165</sup> It is still assumed that the DFES projections for other technologies, accelerated to 2030 for this study, would be installed (see Appendix R)

**Scenario 3 – Meeting South Gloucestershire’s 2030 Electricity Consumption**

This scenario provides enough renewable energy generation to meet the 2030 electricity consumption.

It is still assumed that the DFES projections for South Gloucestershire, accelerated to 2030 for this study, would be installed (see Appendix R) and the additional generation would be covered through the wind and solar PV Search Areas identified in this study.

As the wind Search Areas were more finite than the solar PV Search Areas, and wind turbines have a higher space efficiency for the same energy generation and are generally more efficient, it was assumed a 100% uptake of the available wind installations (1.0MW and 2.5MW SAs), with the additional required generation being met by the solar PV farms. This combination is not mandatory and a different ratio of wind farms to solar PV farms could be used to meet the electricity consumption.

It should be noted the lack of grid connection opportunities may affect the ability of South Gloucestershire to meet the 2030 aim under this scenario; therefore, more investment in the grid would be required to support a greater number of renewables than is currently assumed to be needed from DFES.



*Scenario 3 assumes that majority of homes are primarily heated by heat pumps (circa 73% of homes in the South West as per the DFES) and there will be a 24% increase in number of dwellings with direct electric heating in South Gloucestershire.*



*Scenario 3 assumes that there will be circa 270 times more electric vehicles than in 2020, in the South West, as per the DFES<sup>166</sup>.*



*Scenario 3 would require forty-eight new 50MW solar farms\* and twenty-two new 5MW wind farms in South Gloucestershire.*

\*Assuming a take up of 100% of the wind resource (1.0MW and 2.5MW SAs) identified in this study and meeting the remaining demand with solar PV and existing generation.

This scenario requires consideration by the Council and communities, industry, and other stakeholders as to the appropriate renewable energy generation mix. This could include decisions relating to the planning balance and potential additional constraints within South Gloucestershire.

<sup>166</sup> 7,000 EVs in baseline year and 1,894,000 EVs in 2030 in the South West licence area in Consumer Transformation scenario. <https://www.regen.co.uk/wp-content/uploads/WPD-DFES-2020-technology-summary-report-South-West.pdf>

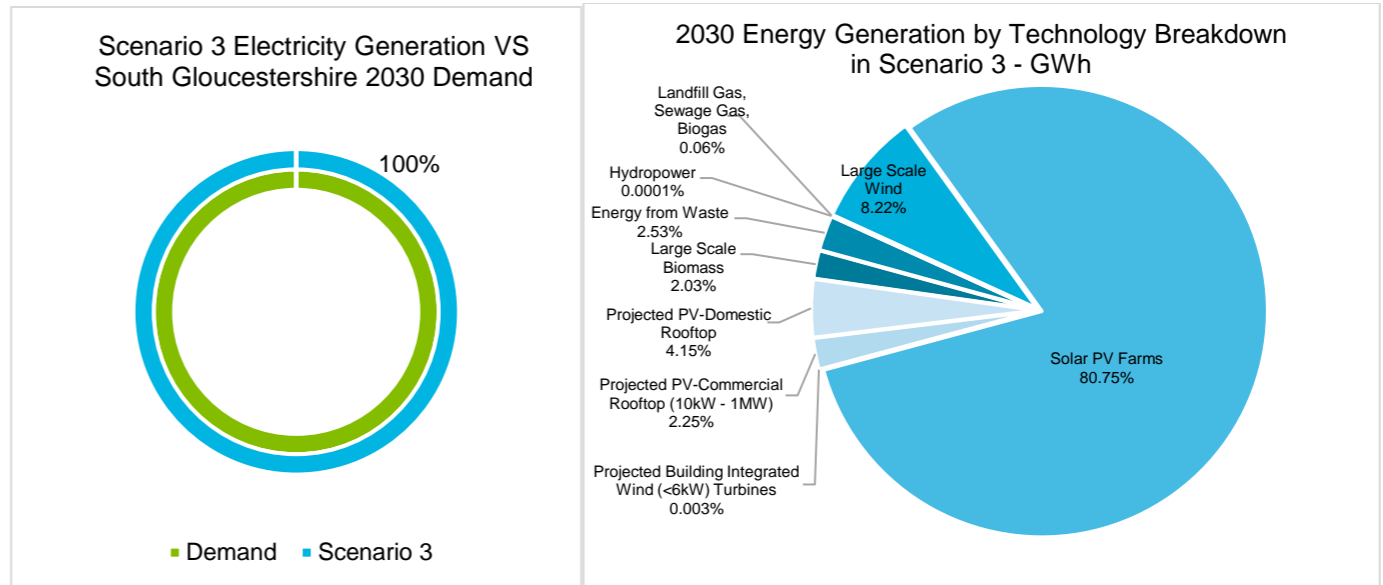

**Figure 76: Electricity Generation Comparison of Scenario 3 and South Gloucestershire’s 2030 Consumption**

**Figure 77: Technology Breakdown of Scenario 3 by GWh**

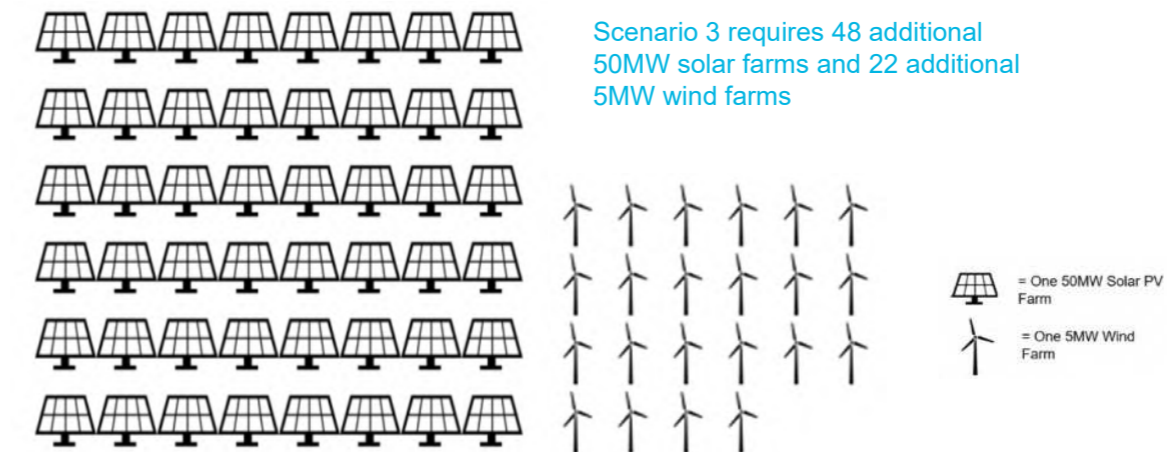

**Figure 78: Pictogram of Number of Additional 50MW Solar Farms and 5MW Wind Farms Required in Scenario 3<sup>167</sup>**

**Table 37: Electricity Generation Potential from New Wind and Solar Farms in Scenario 3<sup>168</sup>**

	Wind Farms				Solar PV			
	Assumed Up-take %	Installed Capacity (MW)	Projected Electricity Generation from Wind (GWh)	Estimated Number of New Wind Farms to be Built until 2030**	Assumed Up-take %	New Installed Capacity (MW)	Projected Electricity Generation from Solar PV (GWh)	Estimated Number of New Solar PV Farms to be Built Until 2030***
<b>Total New Potential based on an assumed up-take</b>	100%	106.0	232.1	22	21.5%	2,405	2,317.1	48

\*\*Assuming 5MW per site (eq. 0.625 km<sup>2</sup>)

\*\*\* Assuming 50MW per site (eq. 1.2 km<sup>2</sup>)

<sup>167</sup> Each solar panel icon is equivalent to one 50MW solar farm. Each wind turbine icon is equivalent to one 5MW wind farm

<sup>168</sup> It is still assumed that the DFES projections for other technologies, accelerated to 2030 for this study, would be installed (see Appendix R)

## 16. Advice on Community Engagement

### 16.1 Community Engagement

Community engagement is essential to ensure the foundations of a long-lasting positive relationship between the community and those involved in developing renewable and low carbon energy proposals. Disregarding the importance of community engagement can lead to negative impacts on the community's economic, environmental or social situation<sup>169</sup>. The Community Engagement Guidance from the Department of Energy and Climate Change (DECC)<sup>170</sup> states that effective engagement can ensure that a development proposal:

- reflects an accurate understanding and appreciation of local interests and concerns;
- provides a better and more timely consideration of the material benefits and impacts of the proposal, which is reflected in the decision-making process; and
- ensures that, if the proposal goes ahead, local people have the opportunity to shape how the development is actually realised and build an ongoing relationship with the developer.

All parties involved in renewable and low carbon energy developments, developers, local authorities and communities, should follow the principles of best practice:



#### Timely

A clear timetable in which engagement opportunities are identified should be created by all parties. Should this change, every effort should be made to communicate this to everyone.

The engagement opportunities should commence early in the process, where it is easy and cost-effective to make changes and so that adequate time is allowed for consideration and response to these changes. Feedback is essential to aid the understanding of how the information collected throughout the engagement process is used.

#### Transparent

All parties should be clear about the interests and people they are representing. Accessible and understandable information should be provided to enable easy engagement with the process. Fixed aspects of the development and community benefits should be made clear, and explanations provided, alongside highlighting areas that are 'up for debate.'



#### Constructive

All engagement should be undertaken in a positive manner, creating and strengthening relationships built on mutual trust. All communication should be a two-way process and actions to adopt links with parties who can advise and support the use of suitable engagement links.

#### Inclusive

Understanding of the whole range of local opinions about the proposed developments should be sought. Exploration into understanding the potential barriers to those actively participating should be undertaken to ensure that there is an equal opportunity for everyone to be heard. A variety of engagement methods will ensure that there is a chance to get involved in a way that is suited to everyone's needs. These practices should be reviewed, and gaps identified and improved upon that will help widen the process and ensure views from across the spectrum of the community are heard.



<sup>169</sup> Code of Practice for Wind Energy Development in Ireland, Guidelines for Community Engagement, <http://www.derryaddwindfarm.ie/wp-content/uploads/sites/6/2017/06/Code-of-Practice-community-engagement.pdf>

<sup>170</sup> Community Engagement for Onshore Wind Developments: Best Practice Guidance for England, DECC, October 2014, [https://assets.publishing.service.gov.uk/government/uploads/system/uploads/attachment\\_data/file/364244/FINAL\\_-\\_Community\\_engagement\\_guidance\\_-\\_06-10-14.pdf](https://assets.publishing.service.gov.uk/government/uploads/system/uploads/attachment_data/file/364244/FINAL_-_Community_engagement_guidance_-_06-10-14.pdf)



### Fair and Evidence Based

All parties should acknowledge and respects the rights of all those who are involved in the process to express their views. Robust, factual information and evidence should form the basis of engagement. Participants should have the opportunity to take an active part in the development proposals and understand how their opinions and input affect the development proposal. Changes made to the development should be done based on the wider community view and not a forthright minority.

### Unconditional

It should be made clear that any engagement, at any stage of the development, does not imply support for the development, nor that approval by the local planning authority has a higher chance of being achieved.



After the completion of this RERAS, a community engagement process should begin. The term 'community' encompasses a variety of people, including communities of place and communities of interest. It is, therefore, essential to ensure that the information within the RERAS is delivered to the community in an accessible and engaging manner.

When considering the term 'local community' in the community engagement process, it is difficult to define the geographical extent of 'local', however, it is essential to ensure that the local community has backed the development proposal, as per footnote 54 in the National Planning Policy Framework<sup>171</sup>. For renewable and low carbon development, the local community may include<sup>172</sup>:

- Proximity to the development;
- Visual impact from the development (the nearest residents may have less of a view of the wind farm than those living further away but with more direct sightlines);
- Level of disruption and nuisance caused by construction activity and traffic;
- How the location is used for work or recreation by the wider community; and
- Noise impact from the development.

The best option to engage with the community would be through public consultation, in which the mapping process is explained to the community, showing each mapping layer and the constraints applied at each step. Through this consultation, clear aims and timeframes can be conveyed to the community and a space can be made for questions and concerns to be raised. This will help improve the understanding of the method taken to define the local SAs and the aims of the council and its importance. An improved understanding of the necessity of renewable and low carbon energy developments and the methodology behind the identification process is likely to result in a minimised pushback from the local community. Through this process, community groups with specific interests in a particular site may come forward and express their interest to get involved in renewable or low carbon energy development.

## 16.2 Community Energy Projects

Community energy projects help to involve the local community and invite local leadership, control and local engagement; they can be fully owned/ controlled by the community or through a partnership with commercial or public sector parties. Community energy projects can include community-owned renewable electricity installations such as solar PV panels, wind turbines or hydroelectric generation.

<sup>171</sup> National Planning Policy Framework, Ministry of Housing, Communities & Local Government, July 2021; [https://assets.publishing.service.gov.uk/government/uploads/system/uploads/attachment\\_data/file/1005759/NPPF\\_July\\_2021.pdf](https://assets.publishing.service.gov.uk/government/uploads/system/uploads/attachment_data/file/1005759/NPPF_July_2021.pdf)

<sup>172</sup> Delivering Community Benefits from Wind Energy Developments: A Toolkit, Centre for Sustainable Energy, July 2009, <https://www.cse.org.uk/downloads/reports-and-publications/community-energy/renewables/Delivering%20community%20benefits%20from%20wind%20energy%20-%20a%20toolkit.pdf>

There is a wide variety of funding opportunities and support for community energy schemes, including the Community Energy Guidance provided by the UK Government<sup>173</sup> and the Community Energy England website<sup>174</sup>. See item 4 in Section 17.5 for details of further work that might be considered by South Gloucestershire Council in relation to community energy projects.

---

<sup>173</sup> Community Energy Guidance, UK Government, 2015; <https://www.gov.uk/guidance/community-energy>

<sup>174</sup> <https://communityenergyengland.org/pages/funding-opportunities-2>

## 17. Planning Policy Approach

### 17.1 What is this section about?

The purpose of the planning system is to contribute to the achievement of sustainable development through economic, social and environmental objectives. The Council is currently preparing its new Local Plan and, as part of this, developing new policies to encourage increased levels of renewable energy generation. Achieving this ambition is critical in the context of the Council's recent Climate Emergency Declaration, which has resulted in an aim of a net zero South Gloucestershire by 2030.

This RERAS provides the evidence to inform the Council's new Local Plan policies for renewable energy and associated infrastructure and contains recommendations for consideration regarding potential policy approaches with regard to:

- Net zero carbon scenarios;
- Search Areas for wind farms and solar PV farms;
- Increased energy storage;
- Encouraging the development of and connection to heat networks;
- Development of other renewable energy resources e.g. biomass, etc.

This section of the study contains policy recommendations. The recommendations are set out by renewable energy type, each with their own table containing references to the relevant evidence as well as the supporting rationale and references to the National Planning Policy Framework (NPPF).

The NPPF (2021) sets out the framework within which Local Plans (including those relating to renewable energy development) should be prepared. The key requirements of NPPF, as related to this RERAS are summarised as follows (numbers relate to NPPF paragraphs<sup>175</sup>):

*152. The planning system should help to contribute to radical reductions in greenhouse gas emissions.....[and]... support renewable and low carbon energy and associated infrastructure.*

*155. To help increase the use and supply of renewable and low carbon energy and heat, plans should:*

- a) maximise the potential for suitable development, while ensuring that adverse impacts are addressed satisfactorily (including cumulative landscape and visual impacts);*
- b) consider identifying suitable areas for renewable and low carbon energy sources, and supporting infrastructure, where this would help secure their development; and*
- c) identify opportunities for development to draw its energy supply from decentralised, renewable or low carbon energy supply systems and for co-locating potential heat customers and suppliers.*

*156. Local planning authorities should support community-led initiatives for renewable and low carbon energy, including developments outside areas identified in local plans or other strategic policies that are being taken forward through neighbourhood planning.*

*157. In determining planning applications, local planning authorities should expect new development to comply with any development plan policies on local requirements for decentralised energy supply unless it can be demonstrated by the applicant, having regard to the type of development involved and its design, that this is not feasible or viable.*

*158. When determining planning applications for renewable and low carbon development, local planning authorities should approve the application if its impacts are (or can be made) acceptable. Once suitable areas for renewable and low carbon energy have been identified in plans, local planning authorities should expect subsequent applications for commercial scale*

<sup>175</sup> <https://www.gov.uk/guidance/national-planning-policy-framework>  
Prepared for: South Gloucestershire Council

*projects outside these areas to demonstrate that the proposed location meets the criteria used in identifying suitable areas.*

References to the NPPF are woven into the text within the tables, to show how the RERAS responds to the requirements.

Prior to setting out the evidence and policy recommendations, some clarifications are provided on the scope and status of these proposals.

## 17.2 Scope of the Policy Recommendations

### 17.2.1 Nationally Significant Infrastructure Projects (NSIP)

Renewable energy applications in South Gloucestershire may exceed 50MW. It should be noted that applications for onshore wind and energy from biomass and/or waste >50MW have a different consenting regime in England. Established by the Planning Act (2008), Nationally Significant Infrastructure Projects (NSIP) bypass the normal local planning requirements. Since 2012, powers have been held by the Planning Inspectorate to receive, examine, and approve applications by way of Development Consent Order (DCO). The Planning Act 2008 defines and establishes a process for examining NSIPs, with the need for such schemes established in National Policy Statements (NPS). The purpose of the NSIP process is to weigh the local impacts of schemes against the national need for such infrastructure.

The NPS concerned with impacts, and other matters which are specific to biomass, energy from waste (EfW) and onshore wind energy is EN-3<sup>176</sup>. EN-3 contains useful information about the factors that influence site selection by developers for renewable energy generating stations, as well as background information on the criteria considered by the Infrastructure Planning Committee (IPC) when considering applications. Whilst pertaining to specific, larger installations, EN-3<sup>176</sup> is relevant in part for smaller installations as well as technologies not addressed. As such, it is useful reference material for the Council.

### 17.2.2 Broader Net Zero Agenda

Reflecting the wider scope of the zero-carbon agenda, there are likely to be a number of overlaps between this RERAS and other evidence being gathered by South Gloucestershire Council. Whilst the use of DFES scenarios means that energy used in or generated for use in individual buildings as well as transport fuel are included in developing baselines and future energy projections, policy recommendations are not provided for these items.

In this study, policy recommendations are provided in relation to Search Areas (SAs) for wind farms, solar PV farms as well as for other renewable energy resources and larger stand-alone technologies with associated infrastructure to encourage the production, generation, storage and supply of renewable energy and fuel.

A major challenge for South Gloucestershire in becoming net zero by 2030 is to deliver on the DFES projections related to the mass uptake of heat pumps for heating buildings and electric vehicles. Achieving the DFES projections in itself will require broader policy interventions, many of which are likely to be beyond the scope of the Local Plan (For example, existing buildings will need to switch their heating systems from gas to renewable/ low carbon sources).

Each of the scenarios presented in this RERAS for setting renewable energy generation aims assume realisation of the DFES projections.

---

<sup>176</sup> [https://assets.publishing.service.gov.uk/government/uploads/system/uploads/attachment\\_data/file/37048/1940-nps-renewable-energy-en3.pdf](https://assets.publishing.service.gov.uk/government/uploads/system/uploads/attachment_data/file/37048/1940-nps-renewable-energy-en3.pdf)



### 17.2.3 Exclusions

No assessment of site-specific access has been undertaken through the RERAS. Instead, assumptions have been made about location and system sizes (without knowing actual detail of proposals). Conversely, it is worth noting that, in some cases large infrastructure can be, for example, air-lifted into place, and it is possible for new access roads to be funded, depending on project-specific economics. AECOM recommends that project developers provide early indications of access plans to the Council when bringing forward proposals for renewable energy projects.

## 17.3 Recommended Policy Approaches

The tables below utilise a referencing system using the following protocol:

- Table Names e.g. Scenarios (SC);
- Table headings e.g. whether the item is evidence (EV), a policy recommendation (PR) or the rationale for the recommendation (RA);
- Each policy recommendation has a number, starting with one and ascending e.g. SC-PR-1, AS-PR-2, etc. These references can also be tracked back to the relevant section of the RERAS;
- Each policy recommendation may have a number of evidence items linked to it; hence evidence is assigned 1a, 1b, etc. There may also be a number of reasons for making a policy recommendation, hence the rationale is also labelled 1a, 1b, etc.

Due to space constraints, abbreviations are used in the below tables. To aid the reader, the key abbreviations are as follows:

- **EV:** Evidence
- **PR:** Policy Recommendation
- **RA:** Rationale
- **NZC:** Net Zero Carbon
- **SGC:** South Gloucestershire Council
- **SAs:** Search Areas
- **WF:** Wind Farms
- **SF:** Solar PV Farms
- **ES:** Energy Storage
- **DH:** District Heating Networks
- **BM:** Biomass
- **SC:** Scenario
- **PPG:** Planning Policy Guidance

**Table 38: Recommended Policy Approaches Relating to Scenarios for NZC (SC)**

Evidence (EV)	Policy Recommendation (PR)	Rationale (RA)
<ul style="list-style-type: none"> <li>• <b>SC-EV-1a:</b> Details of the three NZC scenarios can be found in Section 15;</li> <li>• <b>SC-EV-1b:</b> See Section 16, for guidance in relation to community advice.</li> </ul>	<ul style="list-style-type: none"> <li>• <b>SC-PR-1:</b> It is recommended the three NZC calculations are presented as scenarios, for information only.</li> </ul>	<ul style="list-style-type: none"> <li>• <b>SC-RA-1a:</b> There is no agreed method for calculating zero carbon at a local authority area level, so NZC claims may be challenged;</li> <li>• <b>SC-RA-1b:</b> The Council needs to consult and engage with local people, businesses, industries etc. A discussion about which scenario to aim for (including potential consideration of other scenarios) could be done through engagement on the Local Plan or as part of a wider climate emergency carbon neutral plan;</li> <li>• <b>SC-RA-1c:</b> Given the challenges to achieving NZC aims and the complexity surrounding the energy system that is constantly evolving, it is considered preferable to retain some flexibility in terms of defining carbon neutral and specifying how much RE generation should be targeted. Therefore it is not considered useful to set a specific, rigid aim/ maximum target for renewable energy generation; and</li> <li>• <b>SC-RA-1d:</b> NPPF emphasises the need to maximise the potential for development (NPPF, para 155a). Any perceived restriction placed upon the use of the available resource for renewable energy generation may be viewed as unnecessarily limiting. Therefore, if the numbers used in developing the three NZC scenarios are to be presented as aims in the Local Plan, it is recommended that it be made clear that these are minimum values rather than a cap (refer to Section 14.3.2 and Section 15.4).</li> </ul>

- **SC-EV-2a:** Details of the identified renewable resources in SG are provided in Section 4 to Section 10, and a summary of the findings is provided in Section 15;
- **SC-EV-2b:** Energy storage is discussed in Section 11 of the report; and
- **SC-EV-2c:** Heat opportunities mapping results are included in Section 13. Map E4 shows significant heat clusters and potential for heat networks in Yate, Thornbury, Filton and Downend.
- **SC-PR-2:** It is recommended that the Council aims to maximise the potential for the generation and supply of renewable and low and zero carbon electricity and heat.
- **SC-RA-2a:** NPPF emphasises to help increase the use and supply of renewable and low carbon energy and heat, Local Plans should provide a positive strategy for energy from these sources, that maximises the potential for suitable development, while ensuring that adverse impacts are addressed satisfactorily (including cumulative landscape and visual impacts) (NPPF, para 155a).

**Table 39: Recommended Policy Approaches Relating to Wind Farms (WF)**

Evidence (EV)	Policy Recommendation (PR)	Rationale (RA)
<ul style="list-style-type: none"> <li>• <b>WF-EV-1a:</b> PPG states that there are no hard and fast rules about how suitable areas for renewable energy should be identified;</li> <li>• <b>WF-EV-1b:</b> W7 map presents locations of wind resource SAs across South Gloucestershire;</li> <li>• <b>WF-EV-1c:</b> It should be noted that some of the 1.0Mw and 2.5MW SAs overlap as presented in W7 map;</li> <li>• <b>WF-EV-1d:</b> A list of the constraints applied in identifying the SAs can be found in Section 4.2.1 and Appendix F, along with details of any buffers or separation distance assumptions;</li> <li>• <b>WF-EV-2a:</b> See Table 11 and Table 12 in Section 4.2.2 for details of the 1MW and 2.5MW turbine SAs and total associated maximum installed capacities for each; and</li> </ul>	<ul style="list-style-type: none"> <li>• <b>WF-PR-1:</b> It is recommended that the SAs identified through the RERAS are further refined through the Local Plan process, taking account of other considerations and constraints;</li> <li>• <b>WF-PR-2:</b> It is recommended that proposals for wind turbines of the appropriate number and size (to make the most efficient use of the resource/land) benefit from a presumption in favour of wind development when located within the areas identified for that use through the Local Plan.</li> </ul>	<ul style="list-style-type: none"> <li>• <b>WF-RA-1a:</b> NPPF (2021) (para155) states that “to help increase the use and supply of renewable energy, plans should b) consider identifying suitable areas for renewable and low carbon energy sources;</li> <li>• <b>WF-RA-1b:</b> NPPF (2021) (para158) states that when determining planning applications for renewable and low carbon development, local planning authorities should: b) approve the application if its impacts are (or can be made) acceptable. The Council has considered which constraints would be acceptable and applied these accordingly in the identification of SAs. For Wind and Solar PV developments, the Council in collaboration with WECA, identified certain designations and land uses that were constrained out of the resource assessment process on environmental, technical and safety grounds;</li> <li>• <b>WF-RA-2a:</b> SAs have been identified but the shape and extent of each are produced using</li> </ul>

- **WF-EV-2b:** It is assumed that 500kW SAs can accommodate at least a single 500kW turbine.

three different wind turbine specifications. Where proposals involve turbines within the sizes modelled in the RERAS, it can be assumed that proposals are in compliance with the primary constraints identified. An example for assessment is:

- a. For proposals for turbines up to 500kW capacity, utilise the 500kW SA maps for assessment;
- b. For proposals for turbines up to 1MW capacity, utilise the 1MW SA maps, etc.

- **WF-EV-3a:** WF-EV-1a applies;
- **WF-EV-3b:** WF-EV-1b applies;
- **WF-EV-3c:** The applicant will need to supply the specification of the proposed turbines to understand the noise and topple distance details. Assumptions about noise and topple distances can be found in Table 9 on page 68;
- **WF-EV-3d:** WF-EV-1d applies;
- **WF-EV-3e:** Maps relevant for 2.5MW turbines only can be found in the accompanying document 'South Gloucestershire RERAS – maps'; and
- **WF-EV-3f:** WF-EV-1f applies.

- **WF-PR-3:** It is recommended that proposals for wind turbines >2.5MW within the areas identified through the Local Plan will benefit from a presumption in favour of wind development, subject to compliance with the primary constraints listed in Section 4.2.1 (e.g. noise, topple distances) and consideration of other site specific issues and constraints.

- **WF-RA-3a:** WF-RA-1a applies;
- **WF-RA-3b:** Where proposals do not align with the scheme sizes or technical proposals (e.g. for the calculation of topple distances and noise buffers, etc.) as set out in the RERAS, then the guidance and data supported GIS should be utilised by South Gloucestershire to test whether proposals remain compliant;
- **WF-RA-3c:** Because turbines >2.5MW have not been modelled, the precise shape and extent of SAs are unknown. However, as long as the development proposed is within an identified SA (suggest for 2.5MW turbines), additional checks can be undertaken to ensure compliance, e.g. in relation to topple distances, noise and particularly the primary constraints listed in Section 4.2.1;
- **WF-RA-3d:** WF-RA-1c applies; and
- **WF-RA-3e:** It should be noted that while PPG advises that set-back distances for safety are inflexible, where building/land owners indicate that they wish to do so, advice/guidelines on siting wind turbines (in relation to noise, flicker and topple distance) can be waived, providing it is evidenced that doing

---

so doesn't impact on applying those parameters elsewhere. In such instances, these parameters should pose no obstacle to granting planning permission, subject to other policy requirements being met.

---

- |  |  |  |
|--|--|--|
| <ul style="list-style-type: none"> <li>• <b>WF-EV-4a:</b> WF-EV-1a applies;</li> <li>• <b>WF-EV-4b:</b> Each stage of the mapping process can be found in Appendix E. These maps show where items such as wind resource and land slivers, etc have been identified and may provide an indication where proposals for smaller turbines may be brought forward;</li> <li>• <b>WF-EV-4c:</b> A list of the primary and other constraints applied in identifying the SAs and providing supporting information can be found in tables Appendix F &amp; Appendix G; and</li> <li>• <b>WF-EV-4d:</b> NPPF (2021) (para156) states that local planning authorities should support community-led initiatives for renewable energy, including developments outside areas identified in Local Plans or other strategic policies that are being taken forward through neighbourhood planning.</li> </ul> | <ul style="list-style-type: none"> <li>• <b>WF-PR-4:</b> It is recommended that proposals for wind turbines outside of areas identified as suitable for wind development through the Local Plan should be considered positively, providing it can demonstrate that proposals are compliant with relevant policy and site-specific issues and constraints can be mitigated to the satisfaction of the Council.</li> </ul> | <ul style="list-style-type: none"> <li>• <b>WF-RA-4a:</b> WF-RA-1a applies;</li> <li>• <b>WF-RA-4b:</b> Where proposals involve turbines located outside of SAs it can be assumed, on the basis of the RERAS modelling, that each turbine will be &lt;500kW installed capacity (though there could potentially be proposals containing multiple smaller turbines e.g. 2 x 350kW, etc);</li> <li>• <b>WF-RA-4c:</b> WF-RA-1c applies; and</li> <li>• <b>WF-RA-4d:</b> Because no modelling has been undertaken in relation to these sites, applications will need to provide evidence of the mitigation of all potential constraints to the satisfaction of the Council.</li> </ul> |
| <ul style="list-style-type: none"> <li>• <b>WF-EV-5a:</b> See Table 11 and Table 12 in Section 4.2.2 (page 75) for details of the 1MW and 2.5MW turbine SAs and total associated maximum installed capacities for each;</li> <li>• <b>WF-EV-5b:</b> WF-EV-1d applies; and</li> <li>• <b>WF-EV-5c:</b> It should be noted that some of the 1.0Mw and 2.5MW SAs overlap as presented in W7 map.</li> </ul>   | <ul style="list-style-type: none"> <li>• <b>WF-PR-5:</b> It is recommended that the SAs identified through the RERAS for 1MW and 2.5MW turbines are further refined and safeguarded through the Local Plan process.</li> </ul>   | <ul style="list-style-type: none"> <li>• <b>WF-RA-5a:</b> Larger wind farms are likely to be the most economic solutions for generating renewable electricity; and</li> <li>• <b>WF-RA-5b:</b> There is relatively little area suitable for potential wind energy generation (when compared with potential area for solar PV) and suitable sites for significant wind energy generation outside of the identified SAs are unlikely to be found.</li> </ul>   |
-

- 
- |   |   |  |
|---|---|--|
| <ul style="list-style-type: none"><li>• <b>WF-EV-6a:</b> The recommended safeguarding zones can be found in Map W15 in Appendix E and in the accompanying document 'South Gloucestershire RERAS – maps'; and</li><li>• <b>WF-EV-6b:</b> Assumptions about technologies and associated noise and topple distance buffers can be found in Table 9 on page 68. It should be noted that exclusion zones are only modelled for turbines up to 2.5MW. Proposals for turbines &gt;2.5MW may be prevented where proposed development is sited relatively close to a SA.</li></ul> | <ul style="list-style-type: none"><li>• <b>WF-PR-6:</b> It is recommended that policy measures (e.g. safeguarding) are put in place to ensure that the areas identified for wind development through the Local Plan are not sterilised by non-wind development.</li></ul>   | <ul style="list-style-type: none"><li>• <b>WF-RA-6a:</b> As part of a safeguarding policy, the Council could also consider use of a mechanism to ensure that the sterilisation of opportunities for wind development is prevented;</li><li>• <b>WF-RA-6b:</b> This recommendation assumes it is decided to safeguard the larger Wind Search Areas; and</li><li>• <b>WF-RA-6c:</b> The recommended safeguarding zones are based on modelled topple distances.</li></ul> |
| <ul style="list-style-type: none"><li>• <b>WF-EV-7a:</b> See Table 11 and Table 12 in Section 4.2.2 (page 75) for details of the 1MW and 2.5MW turbine SAs and total associated maximum installed capacities for each;</li><li>• <b>WF-EV-7b:</b> W7 map presents locations of the above SAs across South Gloucestershire; and</li><li>• <b>WF-EV-7c:</b> It should be noted that some of the 1.0Mw and 2.5MW SAs overlap as presented in W7 map.</li></ul>   | <ul style="list-style-type: none"><li>• <b>WF-PR-7:</b> It is recommended that proposals for wind development within areas identified through the Local Plan for 1 and 2.5MW turbines maximise the potential resource. Where this is not the case, applicants should provide evidence as to why this is not feasible or viable.</li></ul>   | <ul style="list-style-type: none"><li>• <b>WF-RA-7a:</b> Larger wind farms are likely to be the most economic solutions for generating renewable electricity; and</li><li>• <b>WF-RA-7b:</b> There is relatively little area suitable for potential wind energy generation (when compared with potential area for solar PV) and suitable sites for significant wind energy generation outside of the identified SAs are unlikely to be found.</li></ul>                |
| <ul style="list-style-type: none"><li>• <b>WF-EV-8a:</b> Constraints maps include sites of existing and consented wind farms (see Section 4 and W2 map); and</li><li>• <b>WF-EV-8b:</b> See Appendix C for details of the sites and installed capacities of existing wind farms in South Gloucestershire.</li></ul>   | <ul style="list-style-type: none"><li>• <b>WF-PR-8:</b> It is recommended that proposals for re-powering of wind farms at end-of-life to an equal or increased capacity will, subject to compliance with the primary constraints listed in Section 4.2.1 (e.g. noise, topple distances), site specific constraints, and other policy considerations should be looked upon favourably.</li></ul> | <ul style="list-style-type: none"><li>• <b>WF-RA-8a:</b> Technology development is moving at pace (with larger turbines becoming available). Existing wind farm sites provide a relatively straight-forward and significant opportunity for increasing generation capacity.</li></ul>  |
-

- **WF-EV-8s:** Map W4 in Appendix E and in the accompanying document ‘South Gloucestershire RERAS – maps’; confirms sufficient wind speed for wind turbine installations at Oldbury.
- **WF-PR-9:** It is recommended that proposals for wind turbines at the former Oldbury Power Station site will, subject to compliance with noise, topple-distance, site-specific constraints and other policy considerations should be looked upon favourably.
- **WF-RA-9a:** The area of the former Oldbury Power Station has been constrained on W7 map because of the existing structure.

**Table 40: Recommended Policy Approaches Relating to Solar PV Farms (SF)**

Evidence (EV)	Policy Recommendation (PR)	Rationale (RA)
<ul style="list-style-type: none"> <li>• <b>SF-EV-1&amp;2a:</b> See Map S7 in Section 5 and in the accompanying document ‘South Gloucestershire RERAS – maps’ for the locations of the solar PV farm SAs;</li> <li>• <b>SF-EV-1&amp;2b:</b> A list of other constraints and information related to assumptions about buffers distances, etc can be found in Appendix J and Map S8 in the accompanying document ‘South Gloucestershire RERAS – maps’;</li> <li>• <b>SF-EV-1&amp;2c:</b> Analysis of solar PV farm SAs in relation to grid connection points with capacity can be found in Map S16 in Section 6 on page 87;</li> <li>• <b>SF-EV-1&amp;2d:</b> Analysis of solar PV farm SAs in relation to landscape character and sensitivity in relation to solar PV farm SAs can be found in Maps S17 in Section 7 on page 89 and in the accompanying document ‘South Gloucestershire RERAS – maps’;</li> <li>• <b>SF-EV-1&amp;2e:</b> Analysis of solar PV farm SAs in relation to demand for heat can be found in Map E6 in the accompanying document ‘South Gloucestershire RERAS</li> </ul>	<ul style="list-style-type: none"> <li>• <b>SF-PR-1-:</b> It is recommended that the SAs identified through the RERAS are further refined through the Local Plan process, taking account of other considerations and constraints. As part of this a strategy approach which takes account of clustering and the potential need to manage cumulative impact should be considered; and</li> <li>• <b>SF-PR-2-:</b> It is recommended that proposals for solar PV farms within the areas identified for that use through the Local Plan benefit from a presumption in favour of solar development.</li> </ul>	<ul style="list-style-type: none"> <li>• <b>SF-RA-1&amp;2a:</b> there are extensive areas that are potentially suitable for solar PV development so, while we do not recommend that it is necessary to safeguard sites for wind, the Council may wish to consider setting a strategy to prioritise specific areas for such development; and</li> <li>• <b>SF-RA-1&amp;2a:</b> The shape and extent of the SAs provided in this RERAS are produced through a process of removing areas that are subject to primary constraints. This allows developers and planning officers to assume certain constraints are not present in SAs.</li> </ul>

– maps’ (Also see Section 13.3.5 in this report); and

- **SF-EV-1&2f:** Other sensitivity testing in relation to solar PV farm SAs can be found in Maps S9 to S14 in Appendix H and the accompanying document ‘South Gloucestershire RERAS – maps’.

- **SF-RV-3a:** SF-EV-1a applies;
- **SF-EV-3b:** A list of the constraints applied in identifying the SAs can be found in Appendix I , along with details of any buffers or separation distance assumptions; and
- **SF-EV-2c:** SF-EV 1c to 1f apply.

- **SF-PR-3:** It is recommended that proposals for solar development outside of areas identified as suitable for that use through the Local Plan should be considered positively, providing it can demonstrate that proposals are compliant with relevant policy and site-specific issues and constraints can be mitigated to the satisfaction of the Council.

- **SF-RA-3a:** SAs have been identified for the potential location of solar PV farms that are at least 5MW installed capacity. In theory, proposals for solar PV farms of less than 5MW may well come forward in non SAs although these are unlikely to be cost-effective.

- **SF-EV-4a:** See Map S2 in the accompanying document ‘South Gloucestershire RERAS – maps’ for the location of existing solar PV farms across South Gloucestershire’;
- **SF-EV-4b:** See Map S15 for the location of pipeline solar PV farm projects;
- **SF-EV-4c:** See Appendix C for details of the installed capacities of the existing solar PV farms in South Gloucestershire;
- **SF-EV-4d:** SF-EV-1b applies; and
- **SF-EV-4e:** SF-EV-2b applies.

- **SF-PR-4:** It is recommended that proposals for re-powering of solar PV farms at end-of-life to an equal or increased capacity, subject to compliance with primary constraints, site specific constraints, and other policy considerations should be looked upon favourably.

- **SF-RA-4a:** The extents of existing solar PV farms have been included within RERAS mapping. Any proposed extension of the size / moving of the PV farm boundaries will require checking that proposals comply with relevant policy and constraints.



**Table 41: Recommended Policy Approaches Relating to Energy Storage (ES)**

Evidence (EV)	Policy Recommendation (PR)	Rationale (RA)
<ul style="list-style-type: none"> <li>• <b>ES-EV-1a:</b> Energy storage is discussed in Section 11 of the report;</li> <li>• <b>ES-EV-1b:</b> Details of the wind farm SAs of &gt;1MW, including potential installed capacities can be found in Table 11 and Table 12 in Section 4.2.2 (page 75);</li> <li>• <b>ES-EV-1c:</b> Locations of the wind farm SAs can be found in MapW7 in section 4.2.2 on page 73;</li> <li>• <b>ES-EV-1d:</b> Details of the solar PV farm SAs, including potential installed capacities can be found in Section 5.2.2 and Map S7;</li> <li>• <b>ES-EV-1e:</b> Locations of the solar PV farm SAs can be found in Map S6 and Map S7 in section 0 on page 82 and the accompanying document 'South Gloucestershire RERAS – maps';</li> <li>• <b>ES-EV-1f:</b> Wind SAs and solar PV farm SAs have been ranked using the WPD grid connection analysis. Maps W16 and S16 in Section 6 on page 87 show results of the assessment;</li> <li>• <b>ES-EV-1g:</b> This general policy recommendation for storage should be read in conjunction with ES-PR-2 (Hydrogen, see Section 12) and Table 42 (recommended policy approaches relating to district heating network) below, which also provides a storage function (also see Section 13) ; and</li> <li>• <b>ES-EV-1h:</b> Details of existing heat demands and potential locations for heat networks, as well as locations for potential</li> </ul>	<ul style="list-style-type: none"> <li>• <b>ES-PR-1:</b> It is recommended that policy encourages applicants promoting schemes for renewable electricity generation of &gt;1MW, regardless of technology, to consider including storage as part of their proposal. This could include some form of energy storage (green hydrogen production, seasonal or battery storage), private wire supply or evidence as to why this is not feasible or viable.</li> </ul> <p><i>It should be noted that WPD maps show only a snapshot in time and are subject to rapid change. The grid capacities maps are useful for all technologies that generate electricity.</i></p>	<ul style="list-style-type: none"> <li>• <b>ES-RA01a:</b> EN-3<sup>177</sup> lists grid connection as a consideration that can affect the siting of renewable technologies;</li> <li>• <b>ES-RA-1b:</b> Increasingly there are constraints placed on renewable electricity generation due to the inability to export at certain times. Where storage and/or private wire supply is feasible and viable, opportunities for storage should be considered to maximise the renewable energy resource and investment;</li> <li>• <b>ES-RA-1c:</b> Distances to suitable grid connections in rural areas are often greater (more costly), with lower starting network capacities and coupled with a lack of demand for power from existing development; and</li> <li>• <b>ES-RA-1d:</b> Battery storage will usually be sited, either next to renewable electricity development or at the site where the electricity is consumed. The physical space and other requirements for such storage will need to be considered as part of the application process.</li> </ul>

<sup>177</sup> [https://assets.publishing.service.gov.uk/government/uploads/system/uploads/attachment\\_data/file/37048/1940-nps-renewable-energy-en3.pdf](https://assets.publishing.service.gov.uk/government/uploads/system/uploads/attachment_data/file/37048/1940-nps-renewable-energy-en3.pdf)

seasonal storage opportunities (e.g. abandoned mines) can be found in Section 13.3.5 and Map E4 on page 123.

- 
- **ES-EV-2a:** Maps H1 and H2 in Section 12.5 on page 115 present the wind SAs and the solar PV farm SAs respectively in relation to their location in relation to industrial clusters with potential for green hydrogen production / use; and
  - **ES-EV-2b:** ES-EV 1a-e apply.
  - **ES-PR-2:** It is recommended that applications for renewable electricity generation of >1MW, located within 1km of an industrial cluster identified as having potential for hydrogen production, consider utilising outputs (via private wire) for such purposes.
 

*The Council may wish to undertake further analysis of existing sites that may employ hydrogen and discuss with stakeholders prior to implementing a policy.*
  - **ES-RA-2a:** Energy storage will play an increasingly important role in UK decarbonisation and therefore opportunities should be maximised;
  - **ES-RA-2b:** Hydrogen could provide a low carbon energy source for difficult to “decarbonise” sectors, such as heavy transport, aviation and various industrial processes, and could also play an important role in system balancing as a multi-vector fuel (a fuel that can be produced or consumed across different energy sectors), using very low-cost electricity during times of over-supply to convert, store and transport renewable energy for applications across the energy system; and
  - **ES-RA-2c:** 1km is an arbitrary figure. The less infrastructure required, the more likely the project is to be viable, but this figure cannot be known without further analysis.

- 
- **ES-EV-3a:** ES-EV-2a applies.
  - **ES-PR-3:** Building on ES-PR-2, it is recommended that applications for new industrial development that may have a use for green hydrogen should be guided towards locations near/in ‘hydrogen clusters’ wherever practical.
 

*See items 2 and 3 in Section 17.5 for details of further work that might be considered by the Council in relation to ‘hydrogen clusters’.*
  - **ES-RA-3a:** ES-RA-2a to 2c apply.
-

- **ES-EV-4a:** The location of abandoned mines with potential use for seasonal storage as well as other potential storage opportunities (e.g. potential for heat networks) can be found in Section 13.3.5 and Map E4 on page 123.
- **ES-PR-4:** It is recommended that applications for renewable electricity generation, or development that is energy intensive and likely to have a surplus of heat, within 1km of a site with potential for seasonal energy storage (e.g. abandoned mine workings) should consider utilising such a facility.
- **ES-RA-4a:** 1km is an arbitrary figure. The less infrastructure required, the more likely the project is to be viable, but this figure cannot be known without further analysis.

**Table 42: Recommended Policy Approaches Relating to District Heating Networks (DH)**

Evidence (EV)	Policy Recommendation (PR)	Rationale (RA)
<ul style="list-style-type: none"> <li>• <b>DH-EV-1a:</b> The RERAS Heat Opportunities Map E4 and Sites of Existing Renewable Energy Map R1 shows the locations of existing renewable electricity and heat generating resources; and</li> <li>• <b>DH-EV-1b:</b> Appendix C identifies a list of what is meant by 'existing renewable heat resource and electricity generating installation';</li> </ul>	<ul style="list-style-type: none"> <li>• <b>DH-PR-1:</b> It is recommended that development proposals for dwellings, employment or depots for hosting transport fleets located within 0.5km of an existing renewable heat resources or renewable electricity generating installations should consider utilising such resources for heating, hot water and/or process use transport fuel.</li> </ul>	<ul style="list-style-type: none"> <li>• <b>DH-RA-1a:</b> The policy is intended to prompt investigation of identifying existing renewables in close proximity to an intended development. This in turn should prompt consideration of how energy might be brought to site (i.e. via a heat network, private wire electricity or for gas or liquid fuels, physical delivery).</li> <li>• <b>DH-RA-1b:</b> The proposed 0.5km is arbitrary. The length (and therefore cost) of infrastructure relative to the value of energy sales will establish viability (so a relatively short distance is suggested) – this cannot be known without knowing locations and nature of off-takers. It may be decided by the Council that further evidence is warranted; and</li> <li>• <b>DH-RA-1c:</b> Heat networks should be considered for 2 main reasons:             <ol style="list-style-type: none"> <li>a. as a means of decarbonising heating in existing buildings, for example where it is not viable or feasible to improve the energy efficiency of the buildings to a level where heat pumps are economically viable.</li> <li>b. Where it is the most practical means of delivering very low carbon/renewable</li> </ol> </li> </ul>

heat in new build taking account of available heat resource (e.g. sewage, mine workings etc) and reject heat from cooling.

- 
- **DH-EV-2a:** Heat opportunities mapping results are included in Section 13. Map E4 shows significant heat clusters and potential for heat networks in Yate, Thornbury, Filton and Downend; and
  - **DH-EV-2b:** The most heat intensive industries are cement, ceramics, iron and steel, glassmaking, chemicals, refineries, paper and pulp, and food and drink which are likely to create a surplus of heat (or power). For more details on the potential for recovering and using surplus heat from industry refer to the following report.  
  
[A Report for DECC: The potential for recovering and using surplus heat from industry](#)<sup>178</sup>
  - **DH-EV-2c:** Section 8 includes the assessment's findings in relation to resource biomass and Table 24 on page 103 details energy from wastes resource potential such as sewage sludge. It should be noted that this policy relates to any future proposals such as EfW plants, wastewater treatment plants (WWT), etc.
  - **DH-EV-3a:** E4 map in section 13.3.1 on page 36 shows the location of the existing heat network in South Gloucestershire at the Frenchay Campus of the University of the West
  - **DH-PR-2:** It is recommended that proposals for development that will host heat intensive activities and are likely to generate excess heat (or power) should consider:
    - a. Potential to be located within 0.5km of a heat demand cluster identified in the Heat Opportunities Map or other identified heat use;
    - b. Enabling heat (power) off-take for supply for other / nearby uses and provide evidence of discussions with potential off-takers for the heat (or power).
  - **DH-PR-3:** It is recommended that development proposals within 0.5km of an existing district heat network fed from a **renewable** (non-fossil
  - **DH-RA-2a:** Consideration of electricity supply is included within the heat network section as, with the move to heat pumps for the provision of space heating and/or domestic hot water, electricity will become the predominant source of energy for such uses; and
  - **DH-RA-2b:** Increasingly, low temperature heat networks are being considered, driven by heat pumps supplied with renewable electricity.
  - **DH-RA-3a:** **Renewable** is purposely highlighted. In the UK there are numerous existing heat networks that are fed from gas CHP engines: whilst efficient, recent changes to
- 

<sup>178</sup> [https://assets.publishing.service.gov.uk/government/uploads/system/uploads/attachment\\_data/file/294900/element\\_energy\\_et\\_al\\_potential\\_for\\_recovering\\_and\\_using\\_surplus\\_heat\\_from\\_industry.pdf](https://assets.publishing.service.gov.uk/government/uploads/system/uploads/attachment_data/file/294900/element_energy_et_al_potential_for_recovering_and_using_surplus_heat_from_industry.pdf)

- of England. The network utilises a natural gas CHP system; and
- DH-EV-3b:** No existing heat network that utilises a renewable source has been identified in South Gloucestershire.
- fuel) source will be expected to connect where feasible and viable.
- carbon factors means that they will cost carbon against a counterfactual of gas boilers into the future. It is important for heat network pipes and associated infrastructure to be installed. This being the case, any Council policy might still wish to include connection to CHP networks. The energy centres attached to such networks can be changed to renewable energy sources in the future in order that decarbonisation can happen;
- DH-RA-3b:** The proposed 0.5km is arbitrary. The length (and therefore cost) of infrastructure relative to the value of energy sales will establish viability (so a relatively short distance is suggested) – this cannot be known without knowing locations and nature of off-takers. It may be decided by the Council that further evidence is warranted; and
  - DH-RA-3c:** It should be noted that if the requirement remains for renewables there would be no existing heat networks to which development could connect.
- 
- DH-EV-4a:** Section 13 of this report presents the results if the heat mapping assessment. Additionally, see E4 to E6 maps in the accompanying document ‘South Gloucestershire RERAS – maps’. E5 and E6 maps shows locations of the SAs in relation to the identified heat cluster. Section 13 includes details of the methodology employed to prepare these maps and the mapping GIS layers have been supplied to the Council.
  - DH-PR-4:** It is recommended that areas identified through the Local Plan for wind farms and solar PV farms are within 0.5km of an identified heat cluster, consideration is given to safeguarding these sites in order to provide electricity for powering heat pumps as part of a private wire / district heat network.
  - DH-RA-4a:** It is difficult to retrofit buildings to be NZC. Of then the roofs have not been designed to be able to host enough solar PV panels to supply heating and power needs. It is therefore sensible, where there is potential for a larger source of renewable electric, that they be fully utilised to decarbonise urban areas.

**Table 43: Recommended Policy Approaches Relating to Biomass (BM)**

Evidence (EV)	Policy Recommendation (PR)	Rationale (RA)
---------------	----------------------------	----------------

- **BM-EV-1a:** Biomass resource has been assessed in Section 8 of this study.
- **BM-EV-1b:** Energy crops (e.g. miscanthus, short-rotation coppice, etc.) and wood fuel resources were considered, and the results are included in section 8.2 and 8.3;
- **BM-EV-1c:** Map B2 in the accompanying document 'South Gloucestershire RERAS – maps' illustrates the constraints that are associated with restrictions to harvesting energy crops;
- **BM-EV-1d:** Map B3 in the accompanying document 'South Gloucestershire RERAS – maps' shows areas of land that could be planted with energy crops after application of the constraints listed in Appendix L;
- **BM-EV-1e:** Refer to the following sources for locations off the national gas grid network in South Gloucestershire;
  - a. [Areas and types of properties off the gas grid](#)<sup>179</sup>
  - b. [LSOA estimates of properties not connected to the gas network](#)<sup>180</sup>
- **BM-EV-1f:** Heat Opportunities Map E4 in the accompanying document 'South Gloucestershire RERAS – maps' shows the locations of urban areas and heat demand clusters in South Gloucestershire.
- **BM-PR-1:** It is recommended that proposals utilising biomass are looked upon favourably where:
  - a. a whole life carbon benefit can be evidenced; and
  - b. the development should be located away from urban areas (and preferably in areas off the gas grid).
- **BM-RA-1a:** Biomass is perhaps the most complex of fuels to evaluate in terms of ensuring that the resource is used to its biggest advantage. There remains some disagreement about the real carbon benefit of utilising biomass as fuel. Emissions relating to the harvesting, processing and transportation of biomass should be accounted for when calculating benefit and understanding replacement-planting;
- **BM-RA-1b:** Whilst the Environment Agency has a strict permitting regime for flue arrangements for biomass plant, there remain concerns about the use of biomass related to impact upon air quality in urban areas;
- **BM-RA-1c:** The RERAS evidence reveals limited opportunity for biomass resource in South Gloucestershire and, whilst the source of the biomass is unknown, that plant is already in operation locally that utilises a large part of the projected resource for generating electricity;
- **BM-RA-1d:** Applications may be received for plant utilising biomass that is sourced outside of South Gloucestershire. The policy recommendations seek to take account of local and non-local sourcing;
- **BM-RA-1e:** the Council should note that the policy recommendation effectively excludes biomass from feeding into district heating schemes as these are likely only to be developed in urban areas of high heat demand density; and
- **BM-RA-1f:** when thinking about local supply of biomass, transportation of the fuel is a fraction of the carbon saving hence spatial relationship between resource and place of

<sup>179</sup> [https://assets.publishing.service.gov.uk/government/uploads/system/uploads/attachment\\_data/file/267375/off\\_gas\\_grid.pdf](https://assets.publishing.service.gov.uk/government/uploads/system/uploads/attachment_data/file/267375/off_gas_grid.pdf)

<sup>180</sup> <https://www.gov.uk/government/statistics/lsqa-estimates-of-households-not-connected-to-the-gas-network>

generation/consumption is not as significant as for other energy resources.

- 
- **BM-EV-2a:** The Consumer Transformation scenario from National Grid (refer to Section 14 and Appendix N) assumes of bioenergy is used in power sector with Carbon Capture and Storage (BECCS) in achieving net zero emissions. BECCS is the combination of bioenergy with carbon capture and storage to capture any CO<sub>2</sub> released during combustion, and the FES assumes that the greenhouse gases released in the scenario will be mainly offset by using BECCS.
  - **BM-PR-2:** It is recommended that proposals for stand-alone electricity generation plant utilising biomass should be required to utilise a BECCS system and a whole life carbon benefit can be evidenced.
  - **BM-RA-2a:** The FES assumes that the greenhouse gases released in each scenario will be mainly offset by using BECCS. The use of BECCS to offset the projected additional greenhouse gas emissions is included in the FES at a national level; and
  - **BM-RA-2b:** Because we are guiding to employ biomass in rural locations, this effectively excludes biomass feeding heat networks (as networks are likely to be in locations with high heat demand density). However, DH-PR-1 and DH-PR 2b to 2d continue to apply.

## 17.4 General policy recommendations

The development of major renewable sites offers opportunities for nature recovery, the development of natural climate solutions and enhancing biodiversity (to a net gain). Policy should reflect this as a requirement, and key locations with opportunities identified when detailed criteria-based policies are formulated.

Moreover, for all renewable energy applications, circular economy principles should be applied to all projects, to ensure best use of materials at end of life, as well as full or enhanced restoration of land.

## 17.5 Further work

This section contains suggestions where further work might be considered by South Gloucestershire Council, as follows:

1. Policy recommendations in relation to District Heating Networks have been provided in the relevant table {*District Heating Networks (DH)*} above. In the absence of more detailed analysis, those recommendations have utilised arbitrary distances between generators and demand. Further detailed feasibility studies could be undertaken to identify indicative schemes and better establish economic viability. Such analysis would enable more detailed and targeted policies to be formulated and implemented.
2. It is recommended (see ES-PR-1 above) that policy encourages applicants promoting schemes for renewable electricity generation of >1MW, regardless of technology, to consider including storage as part of their proposal. This could include for some form of energy storage (green hydrogen production, seasonal or battery storage), private wire supply or evidence as to why this is not feasible or viable. Prior to implementing any policy for storage, South Gloucestershire Council may wish to consider further a strategy for clustering renewable electricity projects in rural areas, in order to reduce grid connection costs and/or to consider outlets/uses for the power. Part of such a study should also include approach to managing cumulative impact in rural areas.
3. It is recommended (see ES-PR-2 above) that applications for renewable electricity generation of >1MW, located within 1km of an industrial cluster identified as having potential for hydrogen production consider utilising outputs (via private wire) for such purposes. South Gloucestershire Council may wish to undertake further analysis of the hydrogen clusters identified in this study and discuss with stakeholders prior to implementing any policy.
4. In relation to renewable and low carbon developments, the Council could offer to facilitate expert services for potential developments, such as site assessments, and to form partnerships with community groups. These partnerships might act as an incentive to other community groups looking to get involved.



# Appendix A : Policy Context and Drivers for Renewable Energy

## A.1 Introduction

The following section sets out the key policies, regulations and incentive schemes relating to renewable energy targets, carbon emissions and waste internationally, nationally, regionally and across South Gloucestershire.

## A.2 International policy context

### The Kyoto Protocol (1998)

The Kyoto Protocol is an international treaty with the goal of achieving the “stabilization of greenhouse gas concentrations in the atmosphere at a level that would prevent dangerous anthropogenic interference with the climate system<sup>181</sup>”.

### The Paris Agreement (2016)

The Paris Agreement entered into force on the 4<sup>th</sup> of November 2016. Under the UN negotiations and alongside over 190 other countries, the UK drafted the Paris Agreement to tackle climate change. The agreement sets out a global framework to limit the effects of climate change by limiting global warming to well below 2°C and pursuing efforts to limit it to 1.5°C. The Agreement additionally sets a target for net zero global emissions in the second half of this century. The UK Government has ratified the agreement.

## A.3 National Policy

### Climate Change Act (2008)

The Climate Change Act sets a legally binding target to reduce UK carbon emissions. The policy has recently been amended<sup>182</sup> to change the minimum percentage by which the net UK carbon account for the year 2050 must be lower than the 1990 baseline, with this increasing from an 80% target to a 100% target. This target means that it is now UK law to produce net zero carbon by the year 2050.

The Climate Change Act also established the Climate Change Committee (CCC), an independent statutory body, to advise the UK Government and the Devolved Administrations on setting and meeting carbon budgets and other related matters.

### National Planning Policy Framework

The National Planning Policy Framework (NPPF) is the overarching planning guidance in England, it sets out the Government’s planning policies for England and guidance on how these should be applied<sup>183</sup>.

The National Planning Policy Framework states that: “*The planning system should support the transition to a low carbon future in a changing climate, taking full account of flood risk and coastal change. It should help to: shape places in ways that contribute to radical reductions in greenhouse gas emissions, minimise vulnerability and improve resilience; encourage the reuse of existing resources, including the conversion of existing buildings; and support renewable and low carbon energy and associated infrastructure.*”

<sup>181</sup> Kyoto Protocol to the United Nations Framework Convention on Climate Change, United Nations, 1998, <https://unfccc.int/resource/docs/convkp/kpeng.pdf>

<sup>182</sup> The Climate Change Act 2008 (2050 Target Amendment) Order 2019 No. 1056, BEIS, 2019; <https://www.legislation.gov.uk/ukdsi/2019/9780111187654>

<sup>183</sup> National Planning Policy Framework, Ministry of Housing, Communities & Local Government, July 2021; [https://assets.publishing.service.gov.uk/government/uploads/system/uploads/attachment\\_data/file/1005759/NPPF\\_July\\_2021.pdf](https://assets.publishing.service.gov.uk/government/uploads/system/uploads/attachment_data/file/1005759/NPPF_July_2021.pdf)

Additionally, the NPPF confirms that, in order to help increase the use and supply of renewable and low carbon energy and heat, “plans should:

- a. *provide a positive strategy for energy from these sources, that maximises the potential for suitable development, while ensuring that adverse impacts are addressed satisfactorily (including cumulative landscape and visual impacts);*
- b. *consider identifying suitable areas for renewable and low carbon energy sources, and supporting infrastructure, where this would help secure their development; and*
- c. *identify opportunities for development to draw its energy supply from decentralised, renewable or low carbon energy supply systems and for collocating potential heat customers and suppliers.”*

(Section 14. Paragraph 151)

The NPPF also requires local planning authorities (LPAs) to support community-led initiatives for renewable and low carbon energy, including developments outside areas identified in Local Plans or other strategic policies that are being taken forward through neighbourhood planning. It also confirms that “when determining planning applications for renewable and low carbon development, local planning authorities should:

- a. *not require applicants to demonstrate the overall need for renewable or low carbon energy, and recognise that even small-scale projects provide a valuable contribution to cutting greenhouse gas emissions; and*
- b. *approve the application if its impacts are (or can be made) acceptable. Once suitable areas for renewable and low carbon energy have been identified in plans, local planning authorities should expect subsequent applications for commercial-scale projects outside these areas to demonstrate that the proposed location meets the criteria used in identifying suitable areas.”*

(Section 14. Paragraph 154)

The Framework illustrates the importance of Local Plans in delivering development that has the backing of local communities; therefore, LPAs should consider the local potential for renewable and low carbon energy generation when preparing Local Plans<sup>184</sup>.

Some of the other key paragraphs from the NPPF relating to energy and climate change are set out below for completeness.

- *Plans should take a proactive approach to mitigate and adapting to climate change, taking into account the long-term implications for flood risk, coastal change, water supply, biodiversity and landscapes, and the risk of overheating from rising temperatures. Policies should support appropriate measures to ensure the future resilience of communities and infrastructure to climate change impacts, such as providing space for physical protection measures, or making provision for the possible future relocation of vulnerable development and infrastructure.*

(Section 14. Paragraph 149)

- *New development should be planned for in ways that:*
  - a. *avoid increased vulnerability to the range of impacts arising from climate change. When new development is brought forward in areas which are vulnerable, care should be taken to ensure that risks can be managed through suitable adaptation measures, including through the planning of green infrastructure; and*
  - b. *can help to reduce greenhouse gas emissions, such as through its location, orientation and design. Any local requirements for the sustainability of buildings should reflect the Government’s policy for national technical standards.*

<sup>184</sup> <https://www.gov.uk/guidance/renewable-and-low-carbon-energy#:~:text=The%20National%20Planning%20Policy%20Framework,planning%20concerns%20of%20local%20communities.>

(Section 14. Paragraph 150)

- *In determining planning applications, local planning authorities should expect new development to:*
  - a. *comply with any development plan policies on local requirements for decentralised energy supply unless it can be demonstrated by the applicant, having regard to the type of development involved and its design, that this is not feasible or viable; and*
  - b. *take account of landform, layout, building orientation, massing and landscaping to minimise energy consumption.*

(Section 14. Paragraph 153)

### UK National Energy and Climate Plan (NECP)

The NECP is the framework by which European Union Member States are required to set out their integrated climate and energy objectives, targets, policies and measures, covering the 5 dimensions of the Energy Union for the period 2021 to 2030. Following the exit of the UK from the EU, the UK was subject to EU legislation during the Brexit transition, so the UK NECP was submitted shortly before the end of 2020.

### UK Industrial Strategy (2017)

The Industrial Strategy, published in November 2017, emphasises the need for clean growth in order to boost economic prosperity within the UK. Some of the stated aims of the Industrial Strategy relevant to energy use in the built environment include:

- Increasing the delivery of new homes;
- Decarbonising the heat supply; and
- Lowering emissions from the transport sector.

There is a particularly strong emphasis on supporting electric vehicle uptake, through investment in charging infrastructure and by extending the plug-in car grant. The Strategy also states that, 'After the Grenfell Review, we will update Building Regulations to mandate that all new residential developments must contain the enabling cabling for charge-points in the homes' (p. 145).

### Resources and Waste Strategy, 2018

The Resources and Waste Strategy<sup>185</sup>, updated in 2018 sets out how England will preserve material resources by minimising waste, promoting resource efficiency and moving towards a circular economy. This strategy plans to encourage the reduction and increased management of waste through policies to support reuse, repair and remanufacture activities and by tackling waste crime.

### Waste Management Plan for England, 2021

The Waste Management Plan for England<sup>186</sup>, updated in 2021 sets out the Government's ambition to work towards a more sustainable and efficient approach to resource use and management. The plan aims to deliver England's waste ambitions through:

- the delivery of sustainable development and resource efficiency, including the provision of modern infrastructure, local employment opportunities and wider climate change benefits;
- ensuring waste management is considered alongside other spatial planning concerns;
- providing a framework in which communities and businesses are engaged with and take more responsibility for their own waste;

<sup>185</sup> Department for Environment, Food & Rural Affairs. *Resources and Waste Strategy: at a glance*. Available at: <https://www.gov.uk/government/publications/resources-and-waste-strategy-for-england/resources-and-waste-strategy-at-a-glance>

<sup>186</sup> Department for Environment, Food & Rural Affairs. *Waste Management Plan for England*. January 2021. Available at: [https://assets.publishing.service.gov.uk/government/uploads/system/uploads/attachment\\_data/file/955897/waste-management-plan-for-england-2021.pdf](https://assets.publishing.service.gov.uk/government/uploads/system/uploads/attachment_data/file/955897/waste-management-plan-for-england-2021.pdf)

- helping to sustainably secure the re-use, recovery or disposal of waste; and
- ensuring new developments complement sustainable waste management.

### National Planning Policy for Waste, 2014

The National Planning Policy for Waste<sup>187</sup> (NPPW) sets out detailed waste planning policies for England and should be read in conjunction with the NPPF, Waste Management Plan for England and the National Policy for Wastewater and Hazardous Waste.

The NPPW focuses on the implementation of waste policies across England's local authorities through the demand, suitability and ability to monitor waste management facilities.

### Clean Growth Strategy (CGS) (2017)

A strategy that sets out the UK Government's ambitious policies and proposals, through to 2032 and beyond for decarbonising all sectors of the UK economy<sup>188</sup>,

The 'power' sector is considered in the CGS policy with an ambition of close to zero emissions by 2050. The strategy considers a potential pathway of growing low carbon sources such as renewables and nuclear to over 80% of electricity generation and phasing out unabated coal power by 2032. The document contains a number of policies and proposals regarding the following topics which are provided in Appendix B.

- Growing low carbon sources of electricity
- Delivering smarter, more efficient energy
- Keeping energy costs down for businesses and households
- Government innovation investment

In addition to the power sector, commercial and industrial (C&I) and domestic buildings sectors are also considered within the Framework.

A key proposal regarding C&I buildings in the document is phasing out of the installation of high carbon forms of fossil fuel heating in new and existing businesses off the gas grid during the 2020s, starting with the new build. It also considers supporting the recycling of heat produced in industrial processes, to reduce business energy bills and benefit local communities.

Additionally, rolling out of low carbon heating is anticipated for UK homes through:

- building and extending heat networks across the country,
- phasing out the installation of high carbon fossil fuel heating in new and existing homes currently off the gas grid during the 2020s, starting with new homes
- Investing in low carbon heating by reforming the Renewable Heat Incentive

### 25 Year Environment Plan (2018)

The plan was published in 2018 and it builds on the proposals and policies outlined in the CGS and aims to improve the environment within a generation and to leave it in a better state than we found it. It details how the government will work with communities and businesses to do this<sup>189</sup>.

The document confirms that the UK Government will work towards eliminating all avoidable waste by 2050 and all avoidable plastic waste by the end of 2042<sup>190</sup> as well as committing to the following action points:

<sup>187</sup> Department for Communities and Local Government. *National Planning Policy for Waste*. October 2014. Available at: [https://assets.publishing.service.gov.uk/government/uploads/system/uploads/attachment\\_data/file/364759/141015\\_National\\_Planning\\_Policy\\_for\\_Waste.pdf](https://assets.publishing.service.gov.uk/government/uploads/system/uploads/attachment_data/file/364759/141015_National_Planning_Policy_for_Waste.pdf)

<sup>188</sup> The Clean Growth Strategy, HM Government, October 2017; [https://assets.publishing.service.gov.uk/government/uploads/system/uploads/attachment\\_data/file/700496/clean-growth-strategy-correction-april-2018.pdf](https://assets.publishing.service.gov.uk/government/uploads/system/uploads/attachment_data/file/700496/clean-growth-strategy-correction-april-2018.pdf)

<sup>189</sup> A Green Future: Our 25 Year Plan to Improve the Environment, HM Government, 2018; [https://assets.publishing.service.gov.uk/government/uploads/system/uploads/attachment\\_data/file/693158/25-year-environment-plan.pdf](https://assets.publishing.service.gov.uk/government/uploads/system/uploads/attachment_data/file/693158/25-year-environment-plan.pdf)

<sup>190</sup> Avoidable means what is Technically, Environmentally and Economically Practicable.

- Exploring different infrastructure options for managing residual waste beyond electricity, including the production of biofuels for transport and emerging innovative technologies;
- Looking at ways to increase the use of heat produced at waste facilities through better connections to heat networks. The facilities will become more efficient and emit less carbon dioxide;
- Investigating ways to cut carbon dioxide emissions from EfW facilities by managing the amount of plastics in the residual waste stream. This will be linked this with any opportunities to recycle more plastics or reduce the amount used.

Among other relevant proposals in this document is a commitment to support extra woodland creation and incentivise more landowners and farmers to plant trees on their land, including agroforestry and bio-energy production.

### The UK Heat Strategy (2013).

The UK Heat Strategy laid out a strategic framework for the transition to a low carbon heat supply.

The strategy highlighted the importance of improving the energy efficiency of buildings and incentivised local authorities to enable the development and expansion of heat networks, for instance, by setting up the Heat Network Development Unit (HNDU) <sup>191</sup>.

### Building Regulations in England (Part L and Part F)

The Building Regulations set the minimum standards for building performance and must be met for a building to be approved for construction. Part L of the Building Regulations focuses on the conservation of heat and power and sets specific requirements for the fabric performance, building services efficiency, overheating and CO<sub>2</sub> emissions and Part F contains guidance on the building ventilation. The Building Regulations are currently being updated and are undergoing a two-part consultation for the Future Homes Standard, including proposed options to increase the energy efficiency requirements for new homes in 2021. The Future Homes Standard will require new build homes to be future-proofed with low carbon heating and world-leading levels of energy efficiency; it will be introduced by 2025<sup>192</sup>. Government responses for part one of the consultation were released in January 2021. The second stage of the consultation ran until 13<sup>th</sup> April 2021 and the feedback is currently being analysed.

The Government's responses to the first stage of the consultation are set out below:

- From 2025, the Future Homes Standard will deliver homes that are zero-carbon ready
- Acknowledgement that there is a need to clarify the Local Planning Authorities' roles in setting energy efficient requirements for new homes that go beyond the minimum standards set out through the Building Regulations
- In 2020, an interim uplift in Part L standards would be introduced that delivered a meaningful reduction in carbon emissions and provided a stepping stone to the Future Homes Standard (this is ongoing)
- A revised package of performance metrics that will ensure a fabric first approach is at the heart of all new homes alongside a low carbon heating systems that have been settled upon. Fabric Energy Efficiency Standard will be one of four performance metrics that achieves this balance
- A comprehensive package of measures to improve compliance, reduce the performance gap and provide more information to energy assessors, building control and homeowners was put forward
- More stringent transitional arrangements to ensure as many homes as possible are being built to new energy efficiency standards would be introduced.

<sup>191</sup> The Future of Heating: Meeting the Challenge, DECC, March 2013; [https://assets.publishing.service.gov.uk/government/uploads/system/uploads/attachment\\_data/file/190149/16\\_04-DECC-The\\_Future\\_of\\_Heating\\_Accessible-10.pdf](https://assets.publishing.service.gov.uk/government/uploads/system/uploads/attachment_data/file/190149/16_04-DECC-The_Future_of_Heating_Accessible-10.pdf)

<sup>192</sup> Ministry of Housing, Communities & Local Government. *The Future Homes Standard: changes to Part L and Part F of the Building Regulations for new dwellings*. January 2021. <https://www.gov.uk/government/consultations/the-future-homes-standard-changes-to-part-l-and-part-f-of-the-building-regulations-for-new-dwellings>

The second stage of the two-part consultation was completed on 13<sup>th</sup> April 2021 and the feedback from this is being analysed.<sup>193</sup>

## A.4 Financial Incentive Schemes

Below is a brief overview of some of the key financial incentive schemes for low and zero-carbon energy in the UK.

### Renewable Heat Incentive (RHI)

The RHI scheme is a government environmental programme to support renewable heat delivered to homes or non-domestic buildings. RHI provides incentives for consumers to install renewable heating in place of fossil fuels. It is open to homeowners and landlords, commercial, industrial, public, not-for-profit and community generators of renewable heat. The domestic RHI scheme has been recently extended to March 2022, but the government announced that non-domestic RHI will close to new applications on 31 March 2021<sup>194</sup>.

The government is currently consulting on a Clean Heat Grant scheme to follow from the RHI building on the Clean Growth Strategy. The consultation document confirms through this new scheme that households and small non-domestic buildings will receive support to enable the installation of heat pumps and, in limited circumstances, biomass, to provide space and water heating<sup>195</sup>.

### Energy Company Obligation (ECO)

The 2011 Energy Bill, which made provision for the Green Deal, also provided for an Energy Company Obligation (ECO). The scheme has been updated several times with the latest update in 2018, known as ECO3 which runs from 2018 to 2022<sup>196</sup>. Under the scheme energy companies are obligated to promote and support carbon emissions reductions to customers.

### Smart Export Guarantee (SEG)

The SEG was introduced in Great Britain on 1 January 2020 and it is available to technologies up to a capacity of 5MW, including:

- Solar photovoltaic
- Hydro
- Micro-combined heat and power (with an electrical capacity of 50kW or less)
- Onshore wind
- Anaerobic digestion<sup>197</sup>

The scheme requires licensed electricity suppliers to offer at least one export tariff, which must always be above zero and makes payment to small-scale low-carbon generators for electricity exported to the National Grid<sup>198</sup>.

### Heat Networks Delivery Unit (HNDU)

The HNDU was set up in 2013 and it provides grant funding and guidance to local authorities in England and Wales for heat network project development<sup>199</sup>.

<sup>193</sup> <https://www.gov.uk/government/consultations/the-future-buildings-standard>

<sup>194</sup> <https://www.gov.uk/government/publications/changes-to-the-renewable-heat-incentive-rhi-schemes>

<sup>195</sup> Future Support for Low Carbon Heat, Department for Business, Energy & Industrial Strategy, July 2020; [https://assets.publishing.service.gov.uk/government/uploads/system/uploads/attachment\\_data/file/970565/green-gas-levy-future-support-low-carbon-heat-govt-response.pdf](https://assets.publishing.service.gov.uk/government/uploads/system/uploads/attachment_data/file/970565/green-gas-levy-future-support-low-carbon-heat-govt-response.pdf)

<sup>196</sup> Energy Company Obligations ECO3: 2018 – 2022, Department of Business, Energy & Industrial Strategy, October 2018

<sup>197</sup> <https://www.gov.uk/government/consultations/the-future-for-small-scale-low-carbon-generation>

<sup>198</sup> <https://www.ofgem.gov.uk/environmental-programmes/smart-export-guarantee-seg/about-smart-export-guarantee-seg>

<sup>199</sup> <https://www.gov.uk/guidance/heat-networks-delivery-unit>

## Green Heat Network Fund (GHNF) Scheme

The GHNF is a capital grant funding programme which is intended to help new and existing heat networks to move to low and zero carbon technologies. Its objectives are to:

- achieve carbon savings and decreases in carbon intensity of heat supplied
- increase the total amount of low-carbon heat utilisation in heat networks (both retrofitted and new heat networks)
- help prepare the market for future low-carbon regulation and ensure compliance with existing regulations (such as the Heat Network (Metering and Billing) Regulations, Heat Network Market Framework and the Future Homes Standard)<sup>200</sup>

## A.5 Ten Point Plan for a Green Industrial Revolution

The Ten Point Plan<sup>201</sup>, publicised in November 2020, details how the UK intends to kick-start a green industrial revolution. Following the economic collapse induced by the coronavirus pandemic, a green industrial revolution, which aims to create and support 250,000 jobs by investing in clean technologies such as wind, carbon capture and low carbon hydrogen and improving the sustainability of national infrastructure such as public transport and new and existing buildings, is emerging. The ten points included in the plan are as follows:

1. Advancing Offshore Wind;
2. Driving the Growth of Low Carbon Hydrogen;
3. Delivering New and Advanced Nuclear Power;
4. Accelerating the Shift to Zero-Emission Vehicles;
5. Green Public Transport, Cycling and Walking;
6. Jet Zero and Green Ships;
7. Greener Buildings;
8. Investing in Carbon Capture, Usage and Storage;
9. Protecting Our Natural Environment; and,
10. Green Finance and Innovation.

### Offshore Wind Sector Deal (March 2020)

Point 1 of the Ten Point Plan highlights the funding and attention that will be placed into advancing offshore wind. The Offshore Wind Sector Deal<sup>202</sup> accentuates the partnership between the Government and the offshore wind sector. The deal includes the details of the investments into the sector, including the plans to provide funding to allow for 40GW (increased from the 30GW set out in the original deal<sup>203</sup>) of offshore wind electricity generation, as mentioned within the Ten Point Plan. This development would result in offshore wind producing enough electricity to power every home in the country by 2030.

Although this is a significant investment into renewable energy generation, the 40GW produced by the offshore wind installations mentioned within the Ten Point Plan and the Offshore Wind Sector Deal will only produce enough electricity to meet the demand for the residential sector only. Other forms of renewable generation are still imperative at a local level in order to meet the demands for sectors such as commercial and transport sectors.

<sup>200</sup> <https://www.gov.uk/government/consultations/green-heat-network-fund-proposals-for-the-scheme-design>

<sup>201</sup> The Ten Point Plan for Green Industrial Revolution, HM Government, November 2020;

[https://assets.publishing.service.gov.uk/government/uploads/system/uploads/attachment\\_data/file/936567/10\\_POINT\\_PLAN\\_BOOKLET.pdf](https://assets.publishing.service.gov.uk/government/uploads/system/uploads/attachment_data/file/936567/10_POINT_PLAN_BOOKLET.pdf)

<sup>202</sup> <https://www.gov.uk/government/publications/offshore-wind-sector-deal/offshore-wind-sector-deal>

<sup>203</sup> <https://www.gov.uk/government/news/new-plans-to-make-uk-world-leader-in-green-energy>

## A.6 Emerging National Policy

Addressing climate change is an issue that is now at the forefront of public and government consciousness. In order to address the issue, new, fast-changing policies are emerging to ensure targets can be met. The most recent announcement from the UK Government, April 2021, set commitments projecting that the UK could cut carbon emissions by 78% by 2035, as per the sixth Carbon Budget.

### Environment Bill 2020

Following on from the UK's 25 Year Environment Plan, the Environment Bill<sup>204</sup> has been produced to help deliver actions set out in the plan. The Environment Bill aims to manage the impact of human activity by creating a more sustainable and resilient economy.

Included in the bill is a UK Environmental Protections Policy which will allow for greater transparency regarding future environmental legislation following the UK's departure from the European Union. In addition, the bill focusses on resource and waste management, air quality, water management, green spaces, and chemical regulations.

### White Paper: Energy

The Energy White Paper 'Powering out Net Zero Future'<sup>205</sup> provides further clarity on the Ten Point Plan and highlights the long-term strategy for the wider energy system that transforms energy, supports green recovery and creates a fair deal for consumers, consistent with target for net zero emissions by 2050.

There are 6 sections within the report:

- Consumers – Commitment to making the right reforms that will protect the interests of consumers and create opportunities to reduce bills and carbon emissions
- Power – Electricity is the key enabler for the transition away from fossil fuels and decarbonising the economy cost-effectively by 2050
- Energy Systems - To deliver energy reliably, while ensuring fair and affordable costs and accelerating our transition to clean energy, we need to create investment opportunities across the UK to enable a smarter, more flexible energy system, which harnesses the power of competition and innovation to the full.
- Buildings - Delivering our net zero target means largely eliminating emissions from domestic and commercial buildings by 2050
- Industrial Energy - By 2050, emissions from industry will need to fall by around 90% from today's levels
- Oil and Gas – Delivering the net zero target by 2050 means transforming the oil and gas sector in the UK

Several specific commitments are made under each section of the Energy White Paper, with the key commitments as follows:

#### Transforming Energy

Building a cleaner, greener future for our country, our people and our planet, by measures including:

- Targeting 40GW of offshore wind by 2030, including 1GW floating wind, alongside the expansion of other low-cost renewables technologies.
- Supporting the deployment of CCUS in four industrial clusters including at least one power CCUS project, to be operational by 2030 and putting in place the commercial frameworks required to help stimulate the market to deliver a future pipeline of CCUS projects.

<sup>204</sup> <https://www.gov.uk/government/publications/environment-bill-2020/30-january-2020-environment-bill-2020-policy-statement#environmental-governance>

<sup>205</sup> [https://assets.publishing.service.gov.uk/government/uploads/system/uploads/attachment\\_data/file/945899/201216\\_BEIS\\_E\\_WP\\_Command\\_Paper\\_Accessible.pdf](https://assets.publishing.service.gov.uk/government/uploads/system/uploads/attachment_data/file/945899/201216_BEIS_E_WP_Command_Paper_Accessible.pdf)



- Establishing a new UK Emissions Trading System, aligned to our net zero target, giving industry the certainty that they need to invest in low-carbon technologies.
- Aiming to bring at least one largescale nuclear project to the point of Final Investment Decision by the end of this Parliament, subject to clear value for money and all relevant approvals.
- Consulting on whether it is appropriate to end gas grid connections to new homes being built from 2025, in favour of clean energy alternatives.
- Growing the installation of electric heat pumps, from 30,000 per year to 600,000 per year by 2028.
- Building world-leading digital infrastructure for our energy system based on the vision set out by the independent Energy Data Taskforce, publishing the UK's first Energy Data Strategy in spring 2021, in partnership with Ofgem.

### **Support a Green Recovery**

Growing our economy, supporting thousands of green jobs across the country in new green industries and creating new export opportunities, by measures including:

- Increasing the ambition in our Industrial Clusters Mission four-fold, aiming to deliver four low-carbon clusters by 2030 and at least one fully net zero cluster by 2040.
- Investing £1 billion up to 2025 to facilitate the deployment of CCUS in two industrial clusters by the mid-2020s, and a further two clusters by 2030, supporting our ambition to capture 10MtCO<sub>2</sub> per year by the end of the decade.
- Working with industry, aiming to develop 5GW of low-carbon hydrogen production capacity by 2030.

### **Creating a Fair Deal for Consumers**

Protecting the fuel poor, providing opportunities to save money on bills, giving us warmer, more comfortable homes and balancing investment against bill impacts, by measures including:

- Creating the framework to introduce opt-in switching, consulting by March 2021 on how it should be designed, tested and incrementally scaled up.
- Considering how the current auto-renewal and roll-over tariff arrangements could be reformed to facilitate greater competition, consulting by March 2021 on how opt-out switching could be tested as part of any future reforms.
- Assessing what market framework changes may be required to facilitate the development and uptake of innovative tariffs and products that work for consumers and contribute to net zero, engaging with industry and consumer groups throughout 2021 before a formal consultation.
- Ensuring the retail market regulatory framework adequately covers the wider market, consulting by spring 2021 on regulating third parties such as energy brokers and price comparison websites.
- Establishing the Future Homes Standard which will ensure that all newbuild homes are zero carbon ready.
- Consulting on regulatory measures to improve the energy performance of homes, and consulting how mortgage lenders could support homeowners in making these improvements.
- Requiring that all rented non-domestic buildings will be Energy Performance Certificate (EPC) Band B by 2030, barring lawful exceptions.
- Extending the Energy Company Obligation to 2026 and expanding the Warm Home Discount to £475 million per year from 2022 to 2025/2026.

There is no target for a specific energy generation mix for 2050 within the Energy White Paper, but investments will be made into areas of innovative technology, such as advanced nuclear and clean hydrogen, which will help to commercialise these new technologies and reduce the overall technology costs, alongside the offshore wind sector.

### White Paper: Planning for the Future

The Planning for the Future White Paper consultation was published by the UK Government in August 2020. The proposal aims to reform the planning system, creating an efficient and modernised planning process that focuses on design and sustainability, improving developer contributions to infrastructure and ensuring land is available for development. The proposals in the paper would apply to England only.

The published document was open for consultation, for 12 weeks from 6th August 2020, closing on 29th October 2020.

The role of Local Plans will be simplified, to focus on the identification of land under three categories:

- Growth Areas; suitable for development, and outline approval for development would be automatic.
- Renewal Areas; suitable for some additional development.
- Protected Areas; where development is restricted.

General development management policies will be set out nationally, with the Local Plans providing clear local rules, design codes and area-specific requirements.

The White Paper aims to support efforts to tackle climate change and maximise environmental benefits. It aims to do this by ensuring the National Planning Policy Framework (NPPF) targets the areas where a new planning system will most effectively address climate change mitigation and adaptation, whilst driving environmental enhancements. The proposal also intends to facilitate improvements in buildings' energy efficiency standards to help target the net zero carbon by 2050 commitment.

The national policies will be set out within the NPPF, with the LA focusing on the locations, standards and design codes. LAs should start to consider the location of the three categories. Rather than general policies, clear and precise rules about these locations should be considered, and specific design codes created. Local Plans will become more visual and map-based, built upon the standards and rules produced.

With the planning white paper still aiming to support the fight against climate change, this RERAS will still feed into the local developments, making it essential regardless of the planning system's changes.

The planning white paper included proposals for consultation. The feedback following the consultation is still being analysed, meaning that the paper still requires governmental approval, and thus the formal writing of legislation. There is no indication on whether the proposals raised within the paper will come forward or what form these proposals will take. There is currently no timescale provided for when the consultation responses will be released.

Suppose the proposals within the paper are initiated. In that case, the Planning for Future White Paper will require the four councils in the West of England to update Local Plans to align with the government's streamlined approach to policy setting, complete plans within 30 months; and, appoint a chief officer for design and placemaking. This digitisation and streamlining of planning applications will accelerate the delivery of new home whilst maintaining a focus on climate change.

## A.7 West of England Planning Policy Context

### The West of England Joint Waste Core Strategy (2011)

The Joint Waste Core Strategy (JWCS) sets out the strategic spatial planning policy to provide waste management infrastructure across the plan area. The joint strategy covers four areas of Bath and

North East Somerset, Bristol, North Somerset and South Gloucestershire, and it applies to all waste, with the exception of most radioactive waste the policy for which is dealt with at a national level<sup>206</sup>.

The document states the strategic objectives of the plan as:

*“To move the management of waste up the waste hierarchy by increasing waste minimisation, recycling and composting then recovering further value from any remaining waste, and only looking to landfill for the disposal of pre-treated waste.”*

Moreover, the strategy confirms that proposals incorporating CHP or electricity generation will help national policy objectives and should be encouraged as such in the JWCS stating:

- *“Energy recovery is placed beneath materials recovery in the waste hierarchy. However, it has a beneficial role to play and this is recognised in national policy in terms of both sustainable waste management and provision of a decentralised, renewable and/or low carbon energy source.”*
- *“In accordance with national policy, the JWCS acknowledges the considerable potential for the production of heat from renewable sources and particularly opportunities for facilities that produce heat and electricity, such as energy from waste.”*

### **Policy 1: Waste Prevention**

The JWCS seeks to encourage sustainable development in terms of a wise use of resources such as water, minerals, land and energy. Waste Prevention will be promoted by 5 target aims:

1. Authorities to work in partnership with businesses and the development industry to raise awareness and to provide information and advice;
2. Raise public awareness on purchasing and lifestyle decisions;
3. Work in partnership with other LA and public bodies to ensure waste prevention is addressed in all contracts for works and services;
4. Ensure the provision of information, appropriate to the planning application, on the following matters: type and volume of waste; on-site waste recycling facilities; minimisation of raw material use; actively reduce, reuse and recycle waste throughout the construction phase; minimise transportation distance if waste disposed of elsewhere; ensure maximum diversion of waste from landfill once site is operational.
5. The Partnership Authorities leading by example.

### **Policy 2: Non-residual Waste Treatment Facilities**

To comply with the draft RSS, approximately 800,000 Tons of additional recycling and composting capacity are required across the South West by 2020. An improved network of household waste recycling centres (HWRC) will be required across the South West to meet recycling and diversion targets.

Planning permissions for non-residual waste treatment facilities involving recycling, storage, transfer, materials recovery and processing (excluding open windrow composting) will be granted, subject to development management policies:

- Land allocated in a Local Plan or development plan document for industrial or storage purposes or has planning permission for such use.
- Previously developed land.
- Existing or proposed waste management sites, subject in the case of landfill and landraising sites or other temporary facilities.

### **Policy 3: Open Windrow Composting**

<sup>206</sup>West of England Joint Waste Core Strategy, WEP, March 2011; <https://www.westofengland.org/waste-planning/adopted-joint-waste-core-strategy>

Open windrow composting involves raw materials being arranged outdoors in piles (windrows) on a hard, impermeable surface, which is then mixed and turned regularly for aeration.

Planning permissions for open windrow composting, with sufficient distance, from any sensitive receptor will be granted, subject to development management policy:

- Existing or proposed waste management sites, subject in the case of landfill and landraising sites or other temporary facilities.
- Sites in the countryside which constitute previously developed land, or redundant agricultural and forestry buildings and their curtilages for proposals for the composting of waste.
- Sites in agricultural use proposing composting of waste for use within that agricultural unit.

#### **Policy 4: Recycling, Storage and Transfer of Construction, Demolition and Excavation Waste at Mineral Sites**

This policy aims to increase the use of secondary and recycled material as substitutes for virgin minerals and consequently reduce the amount of construction, demolition and excavation waste disposed of to landfills.

Planning permissions for development involving recycling, storage and transfer of construction, demolition and excavation waste at mineral sites subject to development management policies, will be granted provided that the proposed development is for a temporary period commensurate with the operational life of the mineral site.

#### **Policy 5 & 6: Residual Waste Treatment Facilities**

Planning permissions for developments involving the treatment of residual wastes where it supports the delivery of the Spatial Strategy will be granted, subject to development management policies:

- 11 discrete sites across the region
- The facilities proposed will be required to contribute to the delivery of the Spatial Strategy.
- Indicative requirements for the South residual waste treatment are:
  - Zone A – ~390,000 TPA
  - Zone B – ~100,000 TPA
  - Zone C – ~150,000 TPA
  - Zone D – ~60,000 TPA
  - Zone E – ~100,000 TPA
- Monitoring will be undertaken to ensure the Spatial Strategy is delivered.

Policy 6 denotes the level of energy recovery expected to be achieved and the market(s) for that energy.

- Materials recovery facilities will be permitted provided that the value of the material and a market demand is presented.
- Energy recovery facilities will be permitted provided: the waste to be treated cannot practically and reasonably be reused, recycled or processed to recover materials; and that energy is recovered, and a market is presented for that energy.

#### **Policy 8 & 9: Landfill, Landraise, Engineering or Other Operations**

A key aim of the JWCS is to ensure that as much waste as possible is diverted away from landfill. To ensure resource use is maximised, all new landfill sites should either provide initial pre-treatment of wastes or be restricted to accept only those wastes that have been pre-treated.

In meeting the sub-region's landfill need, priority will be given to Brownfield land over Greenfield land. Planning permissions will be granted for waste disposal by landfilling, landraising or engineering or other operations, subject to development management policy, provided that:

- Waste that cannot practicably and reasonably be reused, recycled or processed (to recover materials; to produce compost, soil conditioner or inert residues; or to recover energy),
- Proposed developments must minimise waste necessary to deliver the sub-region's needs.
- Proposed developments must not prejudice the satisfactory restoration of mineral working sites in the locality, having regard to the supply and availability of appropriate waste materials for their restoration.
- Proposals are not within major aquifers, source protection zones, European sites of nature conservation or the appropriate buffer; except where it can be demonstrated that the relevant legislative requirements can be met.

In granting planning permission for landfilling or landraising developments, or engineering or other operations, conditions may be imposed limiting both the types and quantities of waste to be deposited in order to conserve capacity for waste that cannot be reused, recycled or processed.

Proposals for landfilling and landraising development, and engineering or other operations, should:

- Incorporate finished levels that are compatible with the surrounding area and any likely settlement.
- Include proposals for aftercare and secure long-term management of the restored site.
- Make provision for landfill gas to be recovered for use as an energy source.
- Make provision, where practical, for appropriate habitat creation for biodiversity benefit.

### **Policy 11 – Planning Designations**

Planning permission will not be granted for waste-related developments which would endanger, or have a significant adverse impact on the following:

- RAMSAR Sites
- Special areas of conservation (SACs), candidate SACs, Special Protection Areas (SPAs) and potential SPAs;
- World Heritage Sites;
- Areas of Outstanding Natural Beauty (AONBs);
- The best and most versatile agricultural land;
- Scheduled Ancient Monuments (SAMs) or Sites of Archaeological Importance;
- National nature reserves (NNRs) or Sites of special scientific interest (SSSIs);
- Ancient semi-natural woodlands;
- Listed Buildings, Registered Parks, Gardens and Battlefields;
- Conservation Areas and sites of Nature Conservation Importance;
- Local Nature Reserves and non-statutory nature reserves;
- Areas of Historic Landscape Value;
- Regionally Important Geological Sites (RIGS)
- Groundwater Source Protection Zones;
- Areas in Flood Zone 3b or where the level of flood risk is considered unsuitable;
- Biodiversity Action Plan habitat and species
- Green Belt, except where very special circumstances are justified.

When assessing each development proposal consideration will be made into whether any significant adverse impact identified could be controlled to acceptable levels.

### Policy 13 – Safeguarding Operational and Allocated Sites for Waste Management Facilities

Operational waste sites are safeguarded, except where alternative suitable facilities are to be provided as part of an authority approved strategy

#### West of England Local Industrial Strategy (2019) <sup>207</sup>

The West of England's Local Industrial Strategy, published in July 2019, conveys the importance of minimising the impact on the environment when implementing the region's four main priorities: cross-sectoral innovation; inclusive growth; addressing the productivity challenge; and delivering innovation in infrastructure delivery.

To ensure the region is active in minimising environmental impact, the strategy confirms that the West of England will embed innovation in tackling significant infrastructure challenges and thus are committed to tackling climate change by contributing to the Clean Growth Grand Challenge mission.

## A.8 South Gloucestershire Local Plan Policy

The existing Development Plan for South Gloucestershire comprises the following documents:

- Local Plan: Core Strategy (2013);
- Local Plan: Policies, Sites and Places (PSP) Plan (2017); and
- West of England Joint Waste Core Strategy (2011).

It should be noted that the Council is planning to transition to a two-tier Local Plan approach by 2023, with the West of England Combined Authority (WECA) Spatial Development Strategy (SDS) and a new South Gloucestershire Local Plan. Once adopted, these documents will constitute the Development Plan for South Gloucestershire, replacing the Core Strategy and PSP Plan.

The policy review below only focuses on policy areas directly related to renewable energy, climate change and sustainable development.

#### Core Strategy (2013)

The Core Strategy<sup>208</sup> was adopted in 2013 and set out the overall development strategy for South Gloucestershire, and the strategic planning policies to deliver it.

#### Key Issue 1 & Objectives

Key Issue 1 of the Core Strategy focuses on reducing and adapting to climate change. The strategy confirms the Council's leadership and facilitation role in managing the impact of climate change, and it draws on mitigation actions such as switching to renewable forms of energy.

- The document sets out three overarching and cross-cutting objectives which are reflected in all the Core Strategy policies, these objectives are presented below:
  - delivering sustainable communities;
  - improving health & well-being;
  - mitigating and adapting to the impacts of climate change.
- The other objectives and policies are grouped into six themes, one of which is "*responding to climate change and high-quality design*".

<sup>207</sup>West of England Local Industrial Strategy, HM Government, July 2019; <https://www.gov.uk/government/publications/west-of-england-local-industrial-strategy/west-of-england-local-industrial-strategy>

<sup>208</sup><https://beta.southglos.gov.uk/wp-content/uploads/South-Gloucestershire-Core-Strategy-2006-2027.pdf>

## High-Quality Design and Responding to Climate Change

This chapter in the Core Strategy sets out the key policies for managing the impact of climate change. Additionally, the section details Core Strategy objectives relating to the roles of the provision of green infrastructure and new renewable and low-carbon energy sources in responding to climate change as demonstrated below:

- *Using design to create attractive, cohesive, safe and inclusive communities with better integration between housing, jobs, services, public transport and facilities, so that people lead healthier lives and have the opportunity to reduce their CO<sub>2</sub> footprint and adapt to the impacts of climate change.*
- *Providing opportunities for flora and fauna to adapt to climate change.*
- *Ensuring that environments for play are delivered as an integral part of the design of sustainable communities.*
- *Promoting energy efficient development and new sources of decentralised, renewable and low carbon sources of energy.*
- *Understanding and reducing susceptibility to flood risk.*

### Policy CS1: High-Quality Design

The policy states that the highest possible standards of design and site planning are required for developments. The policy identifies seven key components of design that the Council is committed to achieving, including sustainable construction and waste reduction.

#### Policy CS1 Criterion 8: Sustainable Construction

The criterion requires consideration of renewable energy generators and district heating networks as it states:

*‘Consideration should also be given to how buildings are laid out and orientated to enhance energy efficiency and the potential for the addition of renewable energy technologies (such as solar panels), if not from the outset, then in the future.’*

#### Policy CS1 Criteria 10: Waste Reduction

This criterion dictates that new developments must incorporate enough spaces for sorting and storing recycled materials. This principle is included to support objectives to reduce the amount of waste that goes to landfill.

### Policy CS2: Green Infrastructure

The policy states that the Council and its partners will ensure that existing and new Green Infrastructure (GI) is planned, delivered and managed whilst realising the potential of GI to assist with mitigation of, and adaption to, climate change. The policy provides a Strategic Green Infrastructure Network map that displays those current and potential GI assets which are important at a strategic scale, and it states:

- *‘GI has a role in absorbing carbon dioxide, reducing ‘urban heat island’ effects, improving air quality and providing opportunities for increasing habitats and connections to help enable wildlife to adapt’*
- *‘GI can encourage walking and cycling, by providing pleasant traffic free routes thus helping to reduce greenhouse gas emissions from car travel. GI can also incorporate space for renewable energy resources.’*

### Policy CS3: Renewable and Low Carbon Energy Generation

The Policy CS3 seeks to set out a policy approach to expanding the renewable energy capacity in South Gloucestershire, where installation would not cause significant demonstrable harm to residential amenity. The policy sets out four criteria that will be given significant weight when assessing renewable or low carbon energy generation proposals in the county. The criteria are listed below:

- *‘the wider environmental benefits associated with increased production of energy from renewable sources’;*

- *'proposals that enjoy significant community support and generate an income for community infrastructure purposes by selling heat or electricity to the National Grid';*
- *'the time limited, non-permanent nature of some types of installations; and';*
- *'the need for secure and reliable energy generation capacity, job creation opportunities and local economic benefits.'*

As part of this policy, there is a requirement for developments to meet the objectives of Policy CS1 (High-Quality Design), as far as engineering requirements permit.

The policy indicates renewable and/or low carbon energy supplies include, but not exclusively, those from biomass and energy crops, Combined Heat and Power (CHP) waste heat from industrial processes, EfW, ground and air source heating and cooling, hydro, solar thermal, photovoltaic generation (including solar farms) and wind power.

#### **Policy CS4: Renewable and Low Carbon District Heat Networks**

The purpose of CS4 is to ensure that the potential to benefit from district heating is considered in development proposals. The policy states that any applications to develop a thermal generating station or proposals that have a capacity to generate significant waste heat as part of an industrial or commercial process must either:

1. include heat recovery and re-use technology; and
2. heat distribution infrastructure; or
3. provide evidence that heat distribution has been fully explored and is unfeasible.

Furthermore, there is a requirement that major development proposals should, where practical and viable:

1. include renewable or low carbon heating or CHP generation and distribution infrastructure on-site and demonstrate how opportunities to accommodate an energy and or district heating solution have been maximised, considering density, mix of uses, layout and phasing; or
2. connect to an existing renewable or low carbon heat distribution network; or
3. provide a heat distribution network as part of the development where there are firm proposals for renewable or low carbon heat generation or CHP and distribution in the locality within a reasonable time frame; or
4. provide evidence that renewable and low carbon sources of heating or CHP have been fully explored and are unfeasible.

Additionally, as part of the policy, developments of less than 100 dwellings or 10,000sqm of non-residential floorspace should connect to any existing available district heat network(s) in the vicinity, providing this is practical and would not adversely affect the viability of the development.

#### **Policy CS4A: Presumption in Favour of Sustainable Development**

This policy seeks to set out a positive policy approach when considering a proposal for sustainable development. The policy dictates that the council will work proactively with the applicants to approve sustainable developments wherever possible.

#### **Policy CS37: Nuclear Related Development**

The policy provides details of how the Council will assess and respond to proposals for nuclear-related development, including proposals for Oldbury Power Station.

Additionally, the document references the Severn Estuary as one of the UK's largest estuaries with potential tidal energy resource, but it states the following regarding the Council's position:

*'South Gloucestershire Council supports the government's conclusions and considers that the significant environmental impacts on the conservation objectives and integrity of the Severn Estuary European (Natura 2000 and Ramsar) site, its marine environment and natural habitats, as well as the landscape and visual impacts, outweighs at this point any advantages in terms of renewable energy*



*generation based on tidal power technology currently available. It is recognised that future schemes will need to be considered with regard to their energy generation potential in relation to their environmental impact.'*

### **Policy CS15: Distribution of Housing**

The policy states that a minimum of 28,355 new homes will be delivered between 2013 and 2027. The policy dictates that this should be done in a sustainable manner through the following distribution and confirms:

*“overall level of housing provision put forward in this Plan reflects the underlying spatial objectives, the sustainable development principles set out in Policy CS1 and the locational strategy set out in Policy CS5.”*

### **Policies, Sites and Places (PSP) Plan (2017)**

The Policies, Sites and Places Plan<sup>209</sup> forms part of the South Gloucestershire Local Plan and it was adopted in 2017 to replace the previous South Gloucestershire Local Plan (adopted in 2006) and Minerals and Waste Local Plan (adopted in 2002).

### **Policy PSP6: Onsite Renewable and Low Carbon Energy**

Policy PSP6 details that all development proposals will be encouraged to minimise their energy demand over and above the current building limit through energy reduction and efficiency measures. Moreover, the policy indicates that residential for sale and speculative commercial development will be encouraged to offer micro renewables as an optional extra. South Gloucestershire Council are responsible for determining applications for onshore renewable energy schemes of up to 50 MW generation capacity.

Additionally, there are two more requirements set out in the policy that are listed below:

- *All new developments will be expected to ensure the design and orientation of roofs will assist the potential siting and efficient operation of solar technology.*
- *All major greenfield residential development will be required to reduce CO<sub>2</sub> emissions further by at least 20% via the use of renewable and/or low carbon energy generation sources on or near the site providing this is practical and viable.*

The policy is aligned to paragraph 94 of the NPPF which requires local planning authorities to adopt proactive strategies to mitigate and adapt to climate change and be delivered through development management.

### **Policy PSP26: Enterprise Areas**

Policy PSP26 identifies three Enterprise Areas that development activity will be co-ordinated to provide essential infrastructure and unlock the early delivery of business and employment opportunities.

The policy sets out six-point policy criteria for acceptable proposal(s) in the in the Enterprise Area, two of which are:

1. *Provide new high quality, people orientated, public space(s) and public realm, which enhance the environment for existing businesses and support the attraction of inward investment; and*
1. *Make appropriate provision towards the sustainability of sites, the wider Enterprise Area and surrounding communities.*

In relation to the above, the documents state that:

*“Encouraging and upholding a high quality, resilient, environmentally sustainable, and inclusive model of economic development, through provision for example of: public transport services, cycling and walking facilities and travel plans, renewable energy and district heating, sustainable urban drainage, waste minimisation and energy efficiency.”*

<sup>209</sup> <https://www.southglos.gov.uk/documents/PSP-Plan-Interim-Web-Version.pdf>

### Policy PSP28: Rural Economy

This policy aims to promote a strong, rural economy by supporting economic growth and expansion in rural areas as required by the NPPF.

The policy states:

*“Sustainable new development which promotes a strong rural economy will be acceptable in rural areas. Proposal(s) for business development outside the defined urban areas and settlement boundaries will be acceptable”* in four cases, one of which is

*“In the case of renewable or low carbon energy generation, which is consistent with Core Strategy Policy CS3.”*

### Policy PSP46: Oldbury New Nuclear Build

The policy sets out nine themes and associated issues that the Council has identified to inform the development of a sustainable and integrated delivery strategy to minimise the proposed nuclear power station's impact.

As of January 2019, works on the Oldbury were suspended due to delays in financial and commercial agreements. In September 2020, Hitachi formally announced the decision to pull out of the scheme <sup>[210]</sup>. It is currently unclear how the project is due to progress.

### South Gloucestershire Resource and Waste Strategy: 2020 and Beyond

The Resource and Waste Strategy set out by South Gloucestershire Council focuses on reducing the production of waste, with a focus on reducing the use of single-use items and encouraging re-use and repair. The strategy aims to increase awareness of and improve on the following topics:

*‘The Value of Resource’ – discourage the ‘take-make-consume-throw away’ outlook at treat all materials as a resource and limit what is thrown away.*

*‘Addressing Plastics’ - if not recycled or disposed of responsibly, plastic can create marine and land pollution, causing long term issues for wildlife and human health. SG aim to explore opportunities presented by the development of new processing technology that will help us to recycle more plastics and to encourage better recycling and reduction of plastic waste and share knowledge and expertise with residents, communities, schools and businesses*

*‘Reducing Waste’ – Single-use items have a significant impact on our environment, both in their creation and disposal; being only used once they are very wasteful. However, many are associated with convenience and through small changes consumption and waste can be reduced.*

*‘Re-use’ - re-using something, either for its original function or a different one, preserves resources, reduces waste and supports a circular economy. Re-use also creates social value and brings communities together.*

*‘Recycling’ - The annual waste analysis in 2019 showed that more has to be done to do to divert waste from the black bin (residual) into recycling.*

*‘The Role of Recovery’ – There will always be some waste that cannot be recycled or reuse. From 2020, SG use Energy Recovery Facilities (ERFs) for our non-recyclable waste and support the development of a heat network from the ERFs*

The Strategy includes the following targets:

- Reduce household waste in South Gloucestershire by 8% of the level in 2020 by 2030; and
- Increase the recycling rate to 65% by 2025, 68% by 2027 and 70% by 2030.

Actions on how these targets and objectives will be achieved are highlighted within the strategy, with a strong focus on community awareness and involvement.

<sup>210</sup> <https://www.telegraph.co.uk/business/2020/09/16/hitachi-abandons-uk-nuclear-power-station-projects/>  
Prepared for: South Gloucestershire Council

## Renewables: Supplementary Planning Document (SPD)

The SPD<sup>211</sup> was adopted in 2014 to help secure delivery of renewables targets and technologies in South Gloucestershire. The document encourages local community engagement with proposed renewables projects and provides guidance for community-led projects

As local planning authorities are responsible for renewable and low carbon energy development of 50 megawatts or less installed capacity,<sup>212</sup> the document confirms that:

*“all development with a generating capacity over 50 MW would be a Nationally Significant Infrastructure Project examined by the Planning Inspectorate and determined by the Secretary of State.”*

Additionally, offshore wind and tidal energy schemes are also excluded from this SPD as these would be considered Nationally Significant Infrastructure Projects. A list of renewables technologies covered by the SPD is set out below:

- Anaerobic digester
- Hydropower
- Biomass
- Landfill gas
- Ground-mounted solar PV
- Solar PV– roof-mounted
- Solar thermal – roof-mounted
- Heat pumps (air, ground and water)
- Wind turbines

The SPD provides guidance and information for Development Management, developers and the general public as to the local authority’s expectations when receiving planning applications and the methodologies/criteria by which they should be assessed. The review section below only focuses on those areas of policy/guidance that are related and may affect this study.

The SPD are likely to require reviewing in light of the RERAS and the development of new Local Plan policies.

### Hydropower

In terms of hydropower, the SPD states:

*Due to the physical geography of the area, the opportunities for implementing hydro power in South Gloucestershire are generally limited to ‘run of river’ schemes that use the natural flow of a river, usually at a weir, diverting some of the water through a turbine to generate electricity. There may also, subject to the constraints of the international designations on the estuary and the agreement of the nuclear companies, be the possibility to investigate the potential for incorporation of hydropower equipment into for example the walls of the lagoon associated with the Oldbury power station.*

### Landfill Gas

The document confirms that at date of publication of the SPD landfill gas was a diminishing resource in South Gloucestershire.

### Solar PV– Ground-Mounted

The SPD indicates South Gloucestershire is located within an area with relatively good solar irradiation levels compared with much of the UK. but it states the suitable areas “*may however be constrained by the presence of landscape designations, and / or features or areas of heritage and or*

<sup>211</sup> <https://beta.southglos.gov.uk/wp-content/uploads/Renewables-SPD.pdf>

<sup>212</sup>

[https://assets.publishing.service.gov.uk/government/uploads/system/uploads/attachment\\_data/file/225689/Planning\\_Practice\\_Guidance\\_for\\_Renewable\\_and\\_Low\\_Carbon\\_Energy.pdf](https://assets.publishing.service.gov.uk/government/uploads/system/uploads/attachment_data/file/225689/Planning_Practice_Guidance_for_Renewable_and_Low_Carbon_Energy.pdf)

*biodiversity value, and / or the presence of other solar parks or forms of development that together lead to cumulative impact.”*

The SDG also elaborates on limited access to the 33kV electricity network for solar installations greater than 5MW.

### Solar PV– Roof-Mounted

The document states:

*At the time of writing the installation of solar PV currently on buildings benefited from Permitted Development (PD) Rights, as specified in Parts 40 and 43 of the GPDO <sup>213</sup>.*

### Biomass

Regarding this technology, the document states:

*“While accepting that the source of biomass cannot generally be controlled through planning, this Council encourages the use of biomass from locally sourced and sustainable sources.”*

### Wind

Regarding this technology, the documents states:

*“despite having significant areas of windspeeds that are suitable for the generation of electricity; the implementation of wind turbines in South Gloucestershire is constrained by a range of factors including its settlement pattern that comprises scattered dwellings as well as villages across much of the rural area.”*

Additionally, the SPD details a wide range of environmental constraints.

### South Gloucestershire Climate Emergency Strategy

The South Gloucestershire Climate Emergency Strategy was published in 2020, following the Climate Emergency declaration made by the Council on 17 July 2019. The Strategy has a 10-year lifespan to 2030 and it explains the Council’s principles and general approach to delivering the aim of South Gloucestershire being carbon neutral by 2030. The document is jointly owned by South Gloucestershire Local Strategic Partnership and South Gloucestershire Council.

In the Climate Emergency Declaration, South Gloucestershire Council pledged to provide the leadership to enable South Gloucestershire to become carbon neutral by 2030.

In addition, the council joined a group of forward-thinking local authorities and signed up to the UK100 pledge to enable our communities to achieve 100% renewable energy across all sectors. The revised UK100 pledge (signed November 2020) commits to net zero council emissions by 2030 and net zero area-wide emissions by 2045.

To deliver these pledges the aims set out in the Climate Emergency Strategy document are:

1. For South Gloucestershire to become carbon neutral by 2030,
2. To maximise the generation of renewable energy from installations located within South Gloucestershire,
3. To ensure South Gloucestershire is prepared for the local impacts of a changing climate,
4. To ensure that nature in our local area is more protected, connected and healthy and that biodiversity is increased,
5. To plant trees across South Gloucestershire by 2030 to double tree canopy cover<sup>214</sup>

<sup>213</sup>[https://www.planningportal.co.uk/info/200187/your\\_responsibilities/37/planning\\_permission/2](https://www.planningportal.co.uk/info/200187/your_responsibilities/37/planning_permission/2)

<sup>214</sup><https://www.southglos.gov.uk/documents/2213-Climate-Emergency-Strategy-Digital-v4.pdf>

## Appendix B : Clean Growth Strategy – Power Sector Policies and Proposals

The UK published the Clean Growth Strategy in October 2017. The Clean Growth Strategy sets out the policies and proposals, for decarbonising all sectors of the UK economy<sup>215</sup>. The power sector policies and proposals are discussed below.

### Growing Low Carbon Sources of Electricity

1. The Government confirm the Government's intention to phase out unabated coal generation by 2025 and will shortly publish the Government's detailed response to the consultation.
2. The Government are delivering new nuclear capacity through the final investment decision on Hinkley Point C and will progress discussions with developers to secure a competitive price for future projects in the pipeline.
3. The Government will work with industry as they develop an ambitious Sector Deal for offshore wind. Provided costs continue to fall, this could result in 10 gigawatts of new capacity built in the 2020s, with the potential to support high-value jobs and a sustainable UK industry exporting goods and services around the world. The Government will also consider whether there could be opportunities for additional offshore wind deployment in the 2020s, if this is cost-effective and deliverable. This would mean up to £557 million for further Pot 2 Contract for Difference auctions, with the next one planned for spring 2019. The Government will work with the Crown Estate and the Crown Estate (Scotland) to understand the potential for deployment of offshore wind in the late 2020s and beyond and it is our current intention that wind projects on the remote islands of Scotland that directly benefit local communities will be eligible for the next Pot 2 auction, subject to obtaining State aid approval.
4. The Government wants to see more people investing in solar without government support and is currently considering options for our approach to small scale low carbon generation beyond 2019. More nascent technologies such as wave, tidal stream and tidal range, could also have a role in the long-term decarbonisation of the UK, but they will need to demonstrate how they can compete with other forms of generation.
5. The Government remain committed to carbon pricing to help reduce emissions in the power sector. Further details on carbon prices for the 2020s will be set out in the autumn 2017 Budget.

### Delivering Smarter, More Efficient Energy

6. The Government will ensure that every household is offered a smart meter by their energy supplier by the end of 2020 and expect energy suppliers to make every effort to provide smart meters to all their customers.
7. The Government, Ofgem and industry will implement the 29 actions set out in the Smart Systems and Flexibility Plan published on 24 July. These will enable technologies such as energy storage and demand-side response to compete effectively within the energy market, help integrate more low carbon generation such as solar into our energy system, and deliver secure, smart appliances and smart tariffs to allow consumers to benefit from using energy at times when it is cheaper. Innovations and other steps to increase flexibility could unlock up to £40 billion in energy cost savings up to 2050.
8. The Government will continue to work with Ofgem and the National Grid to create a more independent system operator which will help to keep household bills low through greater competition, coordination and innovation across the system.
9. The Government will work with Ofgem to ensure the necessary regulatory and market arrangements evolve to support the development of a clean, smart and flexible energy system as outlined in their strategy for regulating the future energy system.
10. The Government will work to ensure significant private investment in new electricity interconnectors, which will help keep prices low for consumers, ensure a more secure grid and help integrate clean generation. Project assessments indicate the potential for at least 9.5

<sup>215</sup> <https://www.gov.uk/government/publications/clean-growth-strategy>  
Prepared for: South Gloucestershire Council

gigawatts more interconnection by the early-to-mid 2020s, in addition to the 4 gigawatts today and the 4.4 gigawatts under construction.

11. Ofgem's price control regime will enable up to £26 billion of investment in upgrading and operating our electricity distribution networks from 2015-23 and will work closely with the industry to capitalise on the opportunities for smart integration of electric vehicles into the electricity system.
12. The Government confirmed that when an installer installs solar panels with a battery in residential accommodation, this can attract a reduced VAT rate of 5 per cent if the installation conditions are met. The Government will keep the tax treatment of technologies such as solar, storage and heat networks under review.

### **Keeping Energy Costs Down for Businesses and Households**

13. The Government has commissioned an independent review into the cost of energy led by Professor Dieter Helm CBE which will recommend ways to deliver the Government's carbon targets and ensure the security of supply at minimum cost to both industry and domestic consumers. Once Ministers have had the opportunity to consider the Helm review's proposals, the Clean Growth Strategy will incorporate its recommendations into our further policy development as appropriate.
14. The Government are publishing a draft bill to require Ofgem to impose a cap on standard variable and default tariffs across the whole market.
15. The existing Levy Control Framework will be replaced by a new set of controls beyond 2020/21. These will be set out later this year.
16. The Government are evaluating the results of the Electricity Demand Reduction Pilot, which has offered organisations £5.4 million of funding for projects that could reduce bills and improve security of supply through making energy savings at peak times.

### **Government Innovation Investment**

- The Government expects to invest around £900 million of public funds between 2015 and 2021 in research and innovation in the power sector.
- Power and smart systems: Ensuring that the power system is smart and resilient to new demands and new sources of supply will be important for energy security, cost and industrial opportunities. The Government, in partnership with the Research Councils and Innovate UK, expects to invest around £265 million in research, development and deployment in this area which will help to reduce the cost of electricity storage, advance innovative demand response technologies and develop new ways of balancing the grid, for example using EVs.
- Nuclear: The government needs to bring down nuclear power costs while maintaining safety by investing in innovation that will help plants be built to time and budget. In partnership with the Research Councils and Innovate UK, the Government expects to invest around £460 million to support work in areas including future nuclear fuels, new nuclear manufacturing techniques, recycling and reprocessing, and advanced reactor design. The Government has asked the Nuclear Innovation and Research Office (NIRO) to convene a new advisory Board, building on the success of the Nuclear Innovation and Research Advisory Board (NIRAB). The Board will provide independent expertise and advice to support and inform the Government's Nuclear Innovation Programme. The Government is also announcing that it will invest £7 million to further develop the capability and capacity of the nuclear regulators to support the development of advanced technologies. The industry is developing a potential nuclear sector deal as part of the Government's Industrial Strategy, co-ordinated around the objective of achieving cost reductions.
- Renewables: The UK already has a world-leading offshore wind sector and is well placed to benefit from further investment in renewables innovation to accelerate cost reduction. The Government, in partnership with the Research Councils and Innovate UK, expects to invest around £177 million to further reduce the cost of renewables, including innovation in offshore wind turbine blade technology and foundations. New innovation opportunities are likely to arise in a number of areas, including floating offshore wind platforms, and advanced solar PV technologies.
- Carbon capture, usage and storage: CCUS could reduce the cost of meeting our 2050 target by supporting emissions reductions in industry, power, heating and transport. Our new approach to CCUS is set out in the Business chapter.

- Ofgem is making available to GB electricity network companies up to £525 million of regulated expenditure between 2016 and 2021. The goal is to support smarter, flexible networks, from enabling the integration of clean generation through to customer-focussed energy efficiency measures. This builds on previous network company innovation which delivered 4.5 – 6.5 times more benefits for consumers than it cost.

## Appendix C : Existing Low and Zero Carbon Energy Technologies<sup>216</sup>

Site Name	Technology	Location (X-coordinate):	Location (y-coordinate):	Site Postcode	Capacity (MW)	Status	Data Source
Avonmouth RSU	Biomass			BS35 4GG	0.958	Operational	SGlos Renewable Energy Database
RLGS-308	Biomass			BS30 8TY	8.32	Operational	SGlos Renewable Energy Database
Sevenside Energy Recovery Centre	Energy from Waste Incineration	354,653	182,612	BS10 7SP	32	Operational	REPD
Avlon Works, Severn Road, Hallen, Bristol	Landfill Gas	354565.00	183236.00	BS10 7SQ	3.00	Operational	SGlos Renewable Energy Database
Bristol Berwick Farm Landfill Site Cory Environmental (Central) Limited	Landfill Gas	355331.544	180310.73	BS10 7RS	0.75	Operational	SGlos Renewable Energy Database
Generation Site	Landfill gas	359728.83	188118.65	BS12 3DF	2.20	Operational	REGO
Generation Site; Viridis Energy (Norgen) Limited	Landfill Gas	359728.827	188118.645	BS12 3DF	0.40	Operational	SGlos Renewable Energy Database
Almondsbury Sports and Social Erection of 2 no. 15 metre wind turbines	Onshore Wind	360762.	183475	BS32 4AA		Operational	Built and Granted Applications
Alveston Wind Park Limited	Onshore Wind	364946.106	184652.208	BS35 3TD	6.846	Operational	Built and Granted Applications
Marshfield Primary School Chippenham Road Marshfield South Gloucestershire SN14 8NY	Onshore Wind	378687.	173781.	SN14 8NY		Operational	Built and Granted Applications
Unknown	Onshore Wind	366459.884	192696.865	GL12	0.005	Operational	Built and Granted Applications

<sup>216</sup> Sub-national total final energy consumption statistics - 2018 (published on September 2020); <https://www.gov.uk/government/statistics/total-final-energy-consumption-at-regional-and-local-authority-level-2005-to-2018>



Wapleyhill (BS37 8RH)	Onshore Wind	371682	179099	BS37 8RH	0.0918	Operational	Built and Granted Applications
Warburtons Limited Bristol Plot 8010 Western Approach (Bristol Wind)	Onshore Wind	354717.305	183838.187	BS35 4GG	0.33	Operational	Built and Granted Applications
Grange Farm, Northwood, Winterbourne, Bristol	Photovoltaic	363,842	182,442	BS36 1RR	21.00	Operational	REPD
Hammond Court Farm	Photovoltaic	363,238	182,360		15.00	Operational	REPD
Hilperton PV	Photovoltaic			BA14 7PJ	7.65	Operational	REGO
Larks Green Solar Farm	Photovoltaic	367,014	186,672	BS37 9TX	49.90	Consented	REPD
Moorend Solar Farm	Photovoltaic	364981.391	178516.412	BS16 6JA	0.72	Operational	Regen
Oakham Farm	Photovoltaic	359904	183151	BS32 4BS	8.00	Operational	SGlos Renewable Energy Database
Parklands	Photovoltaic	361,833	184,427	BS32 4B	4.60	Operational	REPD
Ring O bells Solar Farm (1)	Photovoltaic	372475.87	176999.28	SN18 8HJ	5.00	Operational	Built and Granted Applications
Says Court Farm solar park	Photovoltaic	369115.95	180677.93	BS36 2NY	19.80	Operational	REPD
Severn Beach (Western Approach Solar Park)	Photovoltaic	354510	184911	BS35 4NL	3.50	Operational	REGO
Solarner Park	Photovoltaic			BS35 4NL	0.10	Operational	REGO
Tower Hill Farm	Photovoltaic	367,372	188,828	GL12 8QA	8.10	Operational	REPD
740 Aztec West	Photovoltaic - Roof Mounted			BS32 4UF	0.08	Operational	REGO
a1-a3 Ashville Park	Photovoltaic - Roof Mounted	363877.00	189365.00	Unknown	0.18	Operational	Regen
Amcor Flexibles	Photovoltaic - Roof Mounted	363,561	180,524	BS34 6PT	1.70	Operational	REPD
Amcor Winterbourne	Photovoltaic - Roof Mounted			BS34 8PT	1.57	Operational	REGO

Aviva Bristol	Photovoltaic - Roof Mounted			BS34 8SW	0.05	Operational	REGO
B&Q Cribbs Causeway	Photovoltaic - Roof Mounted			BS10 7TX	0.20	Operational	REGO
BristolIPV	Photovoltaic - Roof Mounted			BS35 4GG	0.15	Operational	REGO
Coveya	Photovoltaic - Roof Mounted	367060.216	172855.483	BS15 5TY	1.44	Operational	Regen
Edge Church PV	Photovoltaic - Roof Mounted			BS32 4TF	0.06	Operational	REGO
Elmtree Farm Tortworth	Photovoltaic - Roof Mounted			GL12 8HJ	0.05	Operational	REGO
Longwell Green	Photovoltaic - Roof Mounted			BS30 7DY	0.18	Operational	REGO
Rolls Royce Filton Campus Building 184 (2)	Photovoltaic - Roof Mounted	360,460	180,792	BS34 6QA	1.40	Operational	REPD
Rolls Royce Filton Campus Building 185 (3)	Photovoltaic - Roof Mounted	360,460	180,792	BS34 6QA	1.80	Operational	REPD
Rolls-Royce Solar PV (1)	Photovoltaic - Roof Mounted	360,460	180,792	BS34 6QA	2.64	Operational	REGO
St Austell Brewery Unit 3	Photovoltaic - Roof Mounted	367835.04	172548.492	BS30 5JE	2.25	Operational	Regen
Tulip Bacon Ltd	Photovoltaic - Roof Mounted	369253.90	178919.08	Unknown	0.21	Operational	Regen
Unknown	Photovoltaic - Roof Mounted			BS32 4TF	0.07	Operational	SGlos Renewable Energy Database
Unknown	Photovoltaic - Roof Mounted			BS34 8SW	0.07	Operational	SGlos Renewable Energy Database

## Appendix D : Existing Renewable Electricity Generated in South Gloucestershire

Technology	Capacity Factor	Installed Capacity (MW)	Energy Generated (MWh)
Micro and Small Wind Power	0.10	1.31	1,149
Wind Farms	0.25	6.90	15,019
Biomass Energy Crop	0.75	9.28	61,361
Energy from Waste	0.90	9.67	76,238
Hydropower	0.29	0.00	3
Landfill Gas	0.46	9.76	39,546
Solar PV Farms	0.11	124.40	120,660
Rooftop Solar PV	0.10	21.98	19,256
Other including food waste, animal slurry, poultry litter, sewage sludge and sewage gas. (AD with CHP)	0.43	0.00	0
Domestic and Non-Domestic Renewable Electricity Technologies Such as Rooftop Solar PV (Electricity)	0.10	0.00	0
<b>Total</b>		<b>183.30</b>	<b>333,232.5</b>

## Appendix E : Wind Energy Resource

### E.1 Introduction

This section of the RERAS focuses on the identification of resource and potential generation from larger scale wind turbines across South Gloucestershire. Information on wind turbines can be found in Section 1.8.1. For this study, the potential for installing wind turbines of 2.5 MW, 1 MW, and 500kW sizes were assessed, and primary constraints associated with wind energy development are considered.

In relation to wind energy, this RERAS is primarily concerned with the spatial identification of potential wind farm developments larger than 5MW total capacity<sup>217</sup>, which is considered the minimum size of a wind farm that could be financially viable without additional incentives<sup>218</sup>. Commercial-scale wind farms seek to install turbines at as large a scale as possible; however, it should be noted that any project (regardless of size) might be of interest to developers and community groups. Therefore, in the interest of completeness, additional suitable areas for installing smaller scale turbines (500kW) are included in the assessment. When assessing a 500kW wind turbine's resources, overlaps with areas suitable for larger turbines were prioritised to the larger turbines.

### E.2 Mapping

The wind resource potential in South Gloucestershire was determined through a series of steps in which the primary constraints associated with wind development have been considered. The datasets corresponding to these constraints are overlaid in GIS maps in stages to produce the final Search Areas shown in this RERAS. This assessment considers a combination of primary constraints comprising those that exclude certain places from being considered as potentially suitable as areas of search for locating wind farms (e.g., international nature conservation designations), as well as those that require further consideration through the Local Plan process (e.g. Areas of Outstanding Natural Beauty (AONB)). For the purposes of this study, these are shown for 'information only' purposes. Each of these different types of constraints, and the stages at which the data layers were applied in the GIS mapping process, was discussed and agreed with the Council.

Maps have been produced to illustrate each stage of the process of identifying primary constraints and opportunities.

The flowchart shown in Figure 79 shows the process steps and the output maps at each mapping stage. More detail on each of the steps is provided in this section. These maps are contained in the accompanying document 'South Gloucestershire RERAS – Maps'.

---

<sup>217</sup> Each 2.5MW and 1.0MW search area can locate a minimum of 5MW wind farm containing 2.5MW or 1.0MW turbines respectively whereas the 500kW search areas can accommodate at least a single 500kW turbine

<sup>218</sup> 5MW was the cut-off point for eligibility of a wind farm to receive subsidies in the Feed-In Tariff (FIT) scheme.



Figure 79: Flowchart of Wind Energy Resource Mapping Process

The varying turbine sizes result in varying cut off wind speeds, noise buffers, tip heights and topple distances, and therefore, each of the turbine sizes investigated has been individually mapped. Table 44 below presents the specifications of the wind turbines that were considered in this study.

**Table 44: Wind Turbines Specifications Used Within This Study**

Turbine Size (Rated Output)	Dimensions	Wind Speed Cut Off	Wind Turbine Density	Approx. Distance Between Turbines	Noise Buffer <sup>219</sup>	Topple Distance Buffer (Tip Height Plus 10%)
2.5 MW	Tip Height <sup>220</sup> : 135 m Rotor Diameter: 100 m Hub Height: 85 m	A lower limit of 5m/s measured at 45m above ground level (agl)	9 MW/km <sup>2</sup>	595 m	600 m	148.5 m
1 MW	Tip Height: 100 m Rotor Diameter: 55 m Hub Height: 60-80 m	A lower limit of 6m/s measured at 45m above ground level (agl)	8 MW/km <sup>2</sup>	399 m	500 m	110 m
500 kW	Tip Height: 70 m Rotor Diameter: 45 m Hub Height: 40-60 m	A lower limit of 6m/s measured at 45m above ground level (agl)	One turbine to be sited on each identified area	One turbine to be sited on each identified area	400 m	77 m

Throughout this study, reference is made to titles and reference numbers to correspond with maps. Screenshots of these maps are included throughout this section. Where maps have been produced for the 500kW, 1MW and 2.5MW separately, maps for the 1MW turbines have been included. Higher-resolution maps and the additional 500Kw and 2.5MW turbine maps are contained in the accompanying document 'South Gloucestershire RERAS – Maps'.

<sup>219</sup> The noise buffers are based on SQW Energy Renewable and Low-Carbon Energy Capacity Methodology – Methodology for the English Regions.

It is understood that the authority may grant planning permission for the construction of a wind turbine generator which does not meet the minimum distance stated in the Bill if the owners of all residential premises which fall within the minimum distance requirement for the proposed wind turbine generator (as stated in the Bill) agree in writing to the construction of the wind turbine generator.

<sup>220</sup> Height to blade tip at the highest point

## Step 1: South Gloucestershire Boundary

Map Reference and Title:

### 1. W1-SG: South Gloucestershire Boundary

This map shows the South Gloucestershire boundary. A higher resolution version of this map is contained in the accompanying document 'South Gloucestershire RERAS – Maps'.

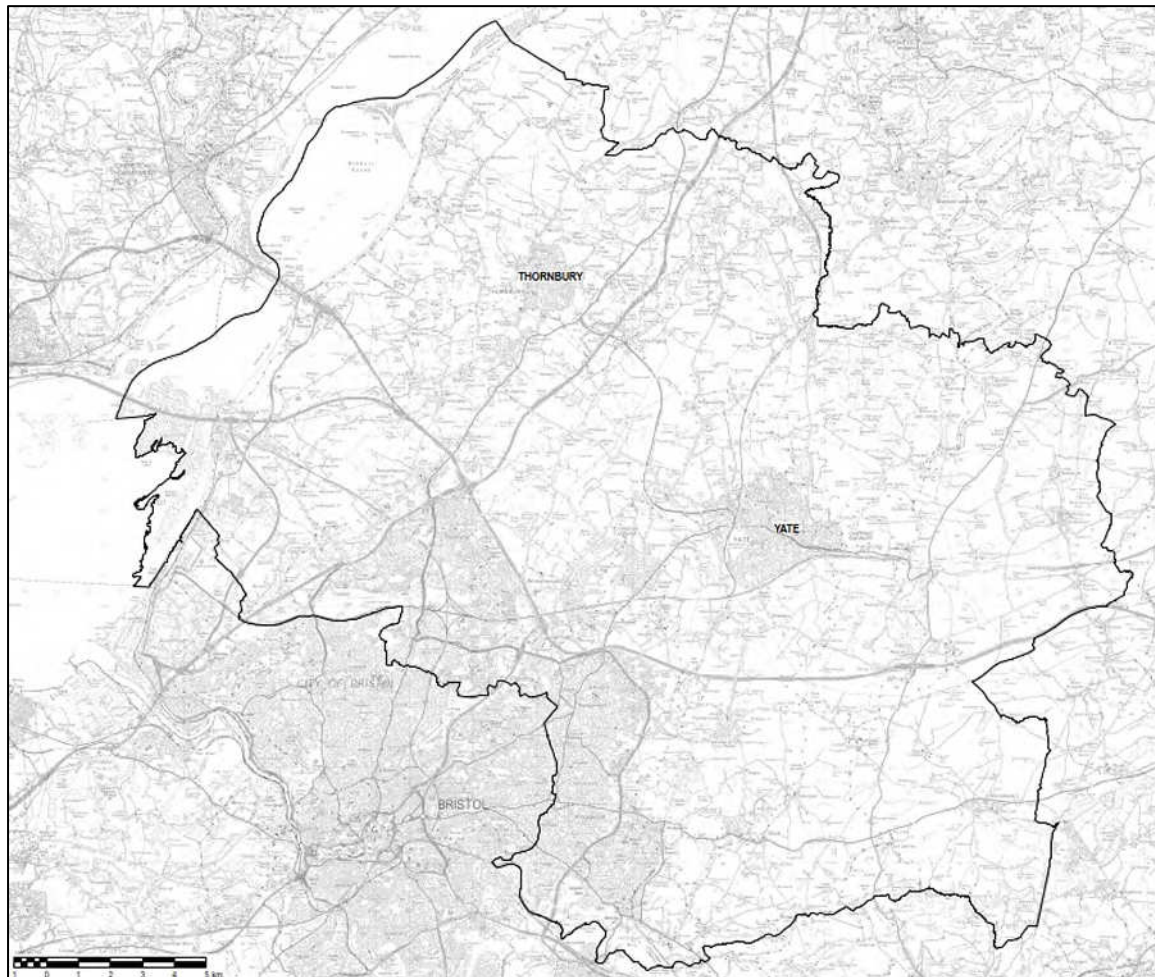

**Figure 80: W1-SG: South Gloucestershire Boundary Map**

## Step 2: Consideration of the Primary Constraints to Wind Energy Development

Map References & Titles:

1. W2-SG-0.5MW: Wind Resource for 500kW Wind Turbines Constraints – Areas to Exclude from Further Consideration
2. W2-SG-1.0MW: Wind Resource for 1.0MW Wind Turbines Constraints – Areas to Exclude from Further Consideration
3. W2-SG-2.5MW: Wind Resource for 2.5MW Wind Turbines Constraints – Areas to Exclude from Further Consideration

The purpose of this step was to identify the maximum potential wind energy resource across South Gloucestershire through the identification of various primary constraints.

The primary constraints are described in more detail below, and a comprehensive table of the data sources and assumptions used is provided in Appendix F. The buffer distances are specific to the different turbine sizes and a few of the designations are constrained to their extent only.

The W2 wind constraints maps illustrate the primary constraints to the development/ deployment of wind turbines. Many of the constraints can be attributed to statutory designations such as those that

protect the environment or heritage. For the GIS mapping process, the constraint, except where specifically stated, relates to the extent of the designation only (with no additional constraint buffer applied beyond the boundary). The constraints applied to the maps in Step 2 were as follows:

- Special Protection Areas (SPA) and foraging buffers;
- Special Areas of Conservation (SAC);
- RAMSAR sites;
- National Nature Reserves (NNR) (none present in South Gloucestershire);
- Sites of Special Scientific Interest (SSSI);
- Scheduled Monuments;
- Listed Buildings (noise buffers have been applied if the building is residential);
- Registered Historic Parks and Gardens; and
- Registered Battlefields.

Many of the 'buffer distances', applied in the maps, are linked to minimising potential impacts upon people or infrastructure. The extent of the buffer areas applied was informed directly by the characteristics of the turbines being assessed (e.g. height of the turbine).

This assessment is based on constraints associated with 500kW, 1.0MW and 2.5MW wind turbines to maintain consistency with the method set out in the NPPF<sup>221</sup>.

Noise buffers were applied around existing dwellings in South Gloucestershire, given the noise-related impact wind turbines can have on building occupants, particularly residents, and the impact that can have spatially on identifying potentially available wind resources. The noise impact can also affect any dwellings close to the border in adjacent authorities; therefore, the noise buffers were also applied to those dwellings. Where it was not possible to identify whether buildings in adjoining authority areas are in residential use, noise buffers have been used for all buildings. These buffers are labelled on the maps separately.

For ease of reference, the assumptions applied to constraints mapping for wind development are provided in Table 45.

**Table 45: Wind Turbine Noise Buffers and Topple Distances**

Turbine Size	Noise Buffer	Topple Distance Buffer (Tip Height Plus 10%)
2.5 MW	600 m	148.5 m
1 MW	500 m	110 m
500 kW	400 m	77 m

The following constraints and their buffer distances (where one has been applied) are fixed for different turbine sizes.

- Ancient Woodlands – a 15-metre buffer has been applied to avoid root damage<sup>222</sup>;
- Broadleaved Woodland a 15-metre buffer has been applied to avoid root damage<sup>222</sup>;
- Existing buildings (extent);
- Watercourses – including major, secondary, and minor rivers, canals and lakes; - a 2-metre buffer has been applied to rivers and streams;
- Active mines/quarries; and
- Local Nature Reserves.

<sup>221</sup> e.g. as defined in SQW Energy Renewable and Low-Carbon Energy Capacity Methodology – Methodology for the English Regions

<sup>222</sup> <https://www.gov.uk/guidance/ancient-woodland-and-veteran-trees-protection-surveys-licences>



The following constraints and their buffer distances (where one has been applied) are likely to change when considering different turbine sizes.

- Major transport infrastructure – topple distance buffers have been applied (tip height +10%);
- Minor transport infrastructure – topple distance buffers (tip height +10%) have been applied;
- Noise buffers – existing dwellings;
- Operational and consented (but not yet constructed) renewables energy development sites (solar PV and wind);
- Ministry of Defence (MoD) Sites; and
- Ministry of Defence (MoD) Low Flying Zones.

It should be noted that, whilst the above issues have been considered in the selection of the Search Areas (SAs), the SAs are not final because:

- The SAs remain subject to further investigation based on information provided in this report (e.g. grid connection or landscape sensitivity) or other site-specific characteristics;
- The SAs are formed using specific technology typologies which, if different from the development proposals, may require the mapping exercise to be rerun; and
- If a private landowner wanted a wind turbine closer to their building than was recommended, and nothing else was adversely affected, then loosening of noise restrictions could be considered.

Additionally, it is important to note that proposals for wind turbines above 2.5MW will change the shape and extent of the SAs, and further work will be needed when considering the proposals, particularly around reapplying the primary constraints listed above.

A higher resolution version of this map is contained in the accompanying document ‘South Gloucestershire RERAS – Maps’.

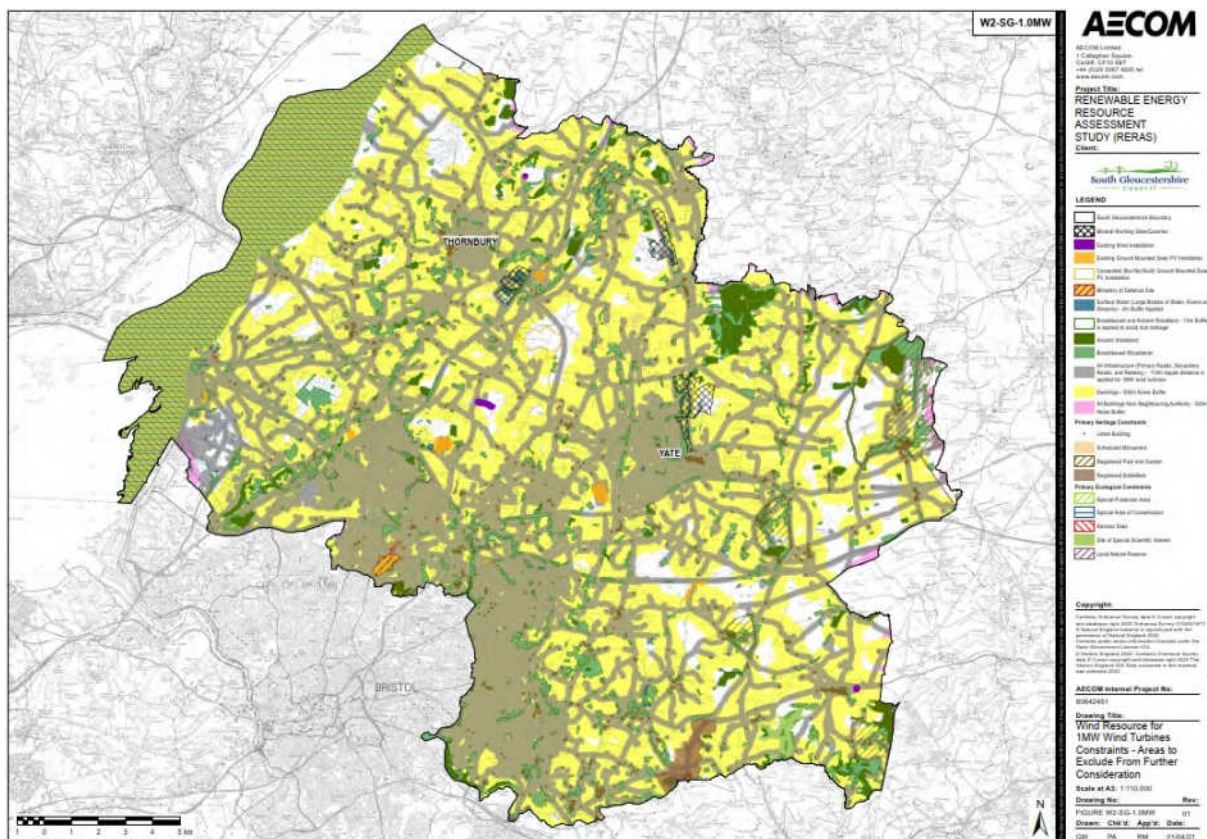

**Figure 81: W2-SG-1.0MW: Wind Resource for 1.0MW Wind Turbines Constraints – Areas to Exclude from Further Consideration Map**

## Policy Recommendation

### Policy Reference: WF-PR-8 (Refer to Table 39 in Section 17)

It is recommended that proposals for re-powering of wind farms at end-of-life to an equal or increased capacity will, subject to compliance with the primary constraints listed in Section 4.2.1 (e.g. noise, topple distances), site specific constraints, and other policy considerations should be looked upon favourably.

## Step 3: Remaining Land Parcels After Applying the Constraints

Map References & Titles:

1. W3-SG-0.5MW: Remaining Land Parcels for 500kW Wind Turbines After Constraining of the Areas that are Excluded from Further Consideration in W2 Map
2. W3-SG-1.0MW: Remaining Land Parcels for 1.0MW Wind Turbines After Constraining of the Areas that are Excluded from Further Consideration in W2 Map
3. W3-SG-2.5MW: Remaining Land Parcels for 2.5MW Wind Turbines After Constraining of the Areas that are Excluded from Further Consideration in W2 Map

W3 maps show the remaining potential wind resource<sup>223</sup> after removing the areas that were constrained in Step 2 of the mapping process. Table 46 summarises this information. A higher resolution version of this map is contained in the accompanying document ‘South Gloucestershire RERAS – Maps’.

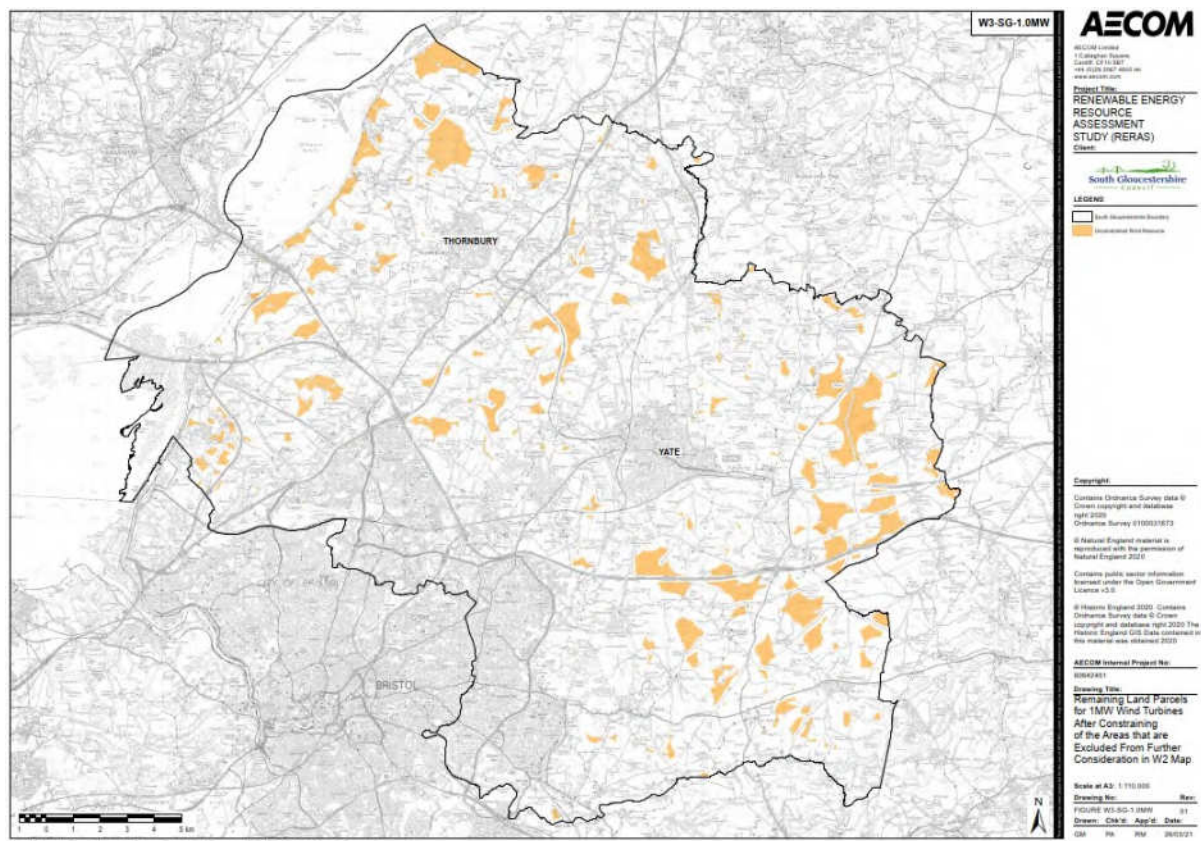

**Figure 82: W3-SG-1.0MW: Remaining Land Parcels for 1.0MW Wind Turbines After Constraining of the Areas that are Excluded from Further Consideration in W2 Map**

<sup>223</sup>Labelled as "Unconstrained Wind Resource" on W3 maps.  
Prepared for: South Gloucestershire Council

**Table 46: Remaining Land Available for Wind Turbines at this Stage of the Assessment and Potential Total Installed Capacity Based on the Available Area**

<b>Map Reference</b>	<b>Note</b>	<b>Remaining Available Land Area (km<sup>2</sup>)</b>	<b>Potential Total Installed Capacity (MW) <sup>224</sup></b>
W3-SG-0.5MW	The remaining available area for 500kW wind turbines at this stage of the assessment	66.84	One turbine to be sited in each identified area.
W3-SG -1.0MW	The remaining available area for 1.0MW wind turbines at this stage of the assessment	36.27	290.16
W3-SG-2.5MW	The remaining available area for 2.5MW wind turbines at this stage of the assessment	18.98	170.82

<sup>224</sup> It should be noted the areas for different wind turbines areas overlap and therefore the maximum potentials in this table cannot be added together.

## Step 4: Wind Resource Based on Wind Speed in South Gloucestershire

### Map References & Titles:

1. W4-SG-0.5MW: Suitable Areas of Land for Installation of 500kW Wind Turbines Constrained by Wind Speed Only
2. W4-SG-1.0MW: Suitable Areas of Land for Installation of 1.0MW Wind Turbines Constrained by Wind Speed Only
3. W4-SG-2.5MW: Suitable Areas of Land for Installation of 2.5MW Wind Turbines Constrained by Wind Speed Only

The areas shown on the W4 maps are only constrained by the technology's ability to utilise the available resource based on wind speed at a particular height above ground level (agl).

The maps show wind speeds sufficient for the potential development of wind farms. The performance of wind turbines is a function of wind speed. Utilising Ordnance Survey maps and Meteorological Office data, AECOM created a 1.5km<sup>2</sup> grid GIS data layer for the South Gloucestershire area showing average annual wind speed at 45m agl attributed to each individual 1.5km<sup>2</sup> cell.

No wind energy potential was assumed for the 500kW, and 1.0MW turbine size in areas with an average annual wind speed of less than 6.0 m/s, meaning the wind speed resource areas for the 500kW and 1.0MW turbine sizes are the same. A similar assumption was made for the 2.5MW turbine size, but with wind speeds of less than 5.0 m/s. A higher resolution version of this map is contained in the accompanying document 'South Gloucestershire RERAS – Maps'.

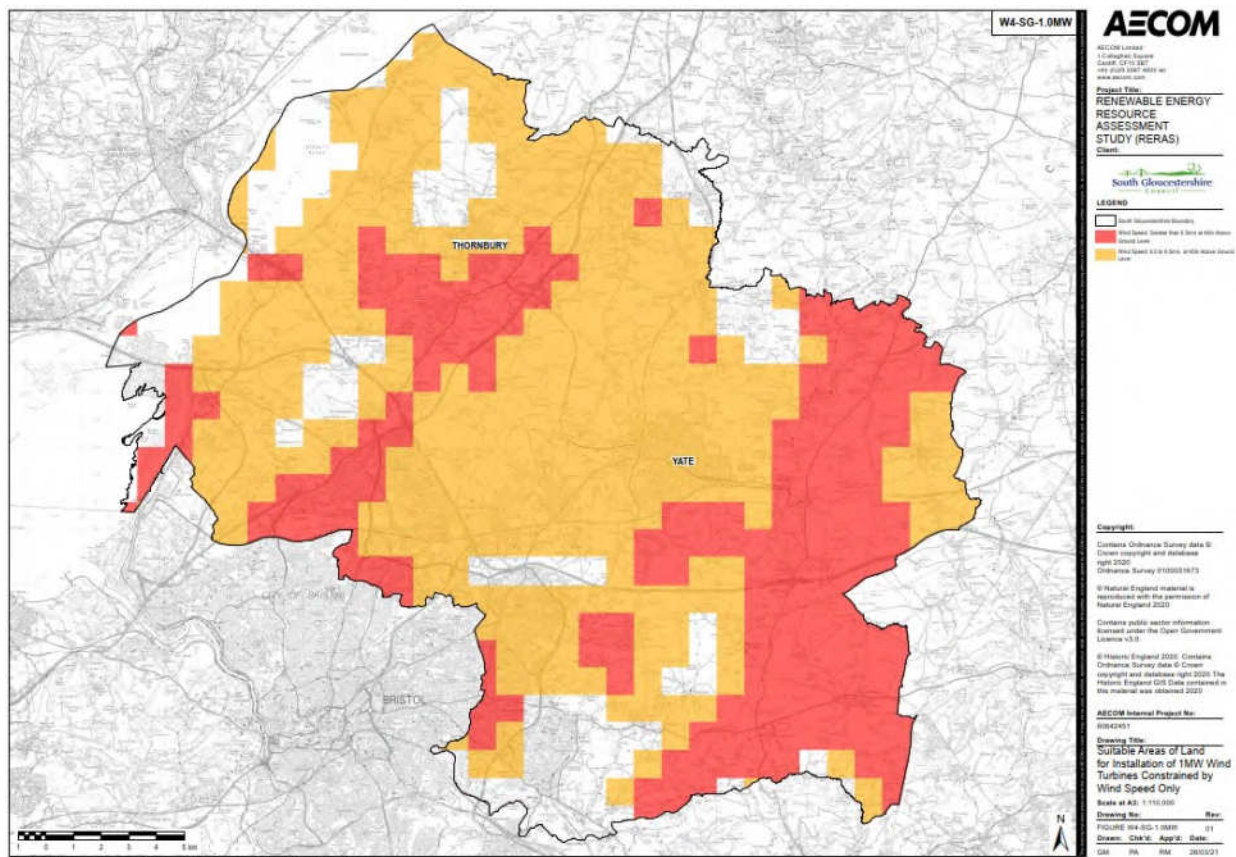

**Figure 83: W4-SG-1.0MW: Suitable Areas of Land for Installation of 1.0MW Wind Turbines Constrained by Wind Speed Only Map**

The wind resource areas for wind turbines can be seen in Table 47.

**Table 47: Wind Resource Based on Wind Speed in South Gloucestershire**

	2.5MW Turbines	1.0MW and 500kW Turbines
Total South Gloucestershire Area (km <sup>2</sup> )	536.40	536.40
Suitable Area (km <sup>2</sup> )	512.43	451.37
Proportion of Area Suitable (%)	96%	84%

**Step 5: Remaining Potential Wind Resource After Combining W3 Maps (Resource After Constraining) and W4 (Showing Sufficient Wind Speeds)**

Map References & Titles:

1. W5-SG-0.5MW: Remaining Land Parcels from Resource Map (W3) After Constraining the Unsuitable Areas due to Wind Speed Map (W4) for Installation of 500kW Wind Turbines
2. W5-SG-1.0MW: Remaining Land Parcels from Resource Map (W3) After Constraining the Unsuitable Areas due to Wind Speed Map (W4) for Installation of 1MW Wind Turbines
3. W5-SG-2.5MW: Remaining Land Parcels from Resource Map (W3) After Constraining the Unsuitable Areas due to Wind Speed Map (W4) for Installation of 2.5MW Wind Turbines

Unsuitable areas due to insufficient wind speed were removed from W3 maps and presented. Table 48 below shows the remaining potential wind resource<sup>225</sup> at this stage and its potential total installed capacity. A higher resolution version of this map is contained in the accompanying document ‘South Gloucestershire RERAS – Maps’.

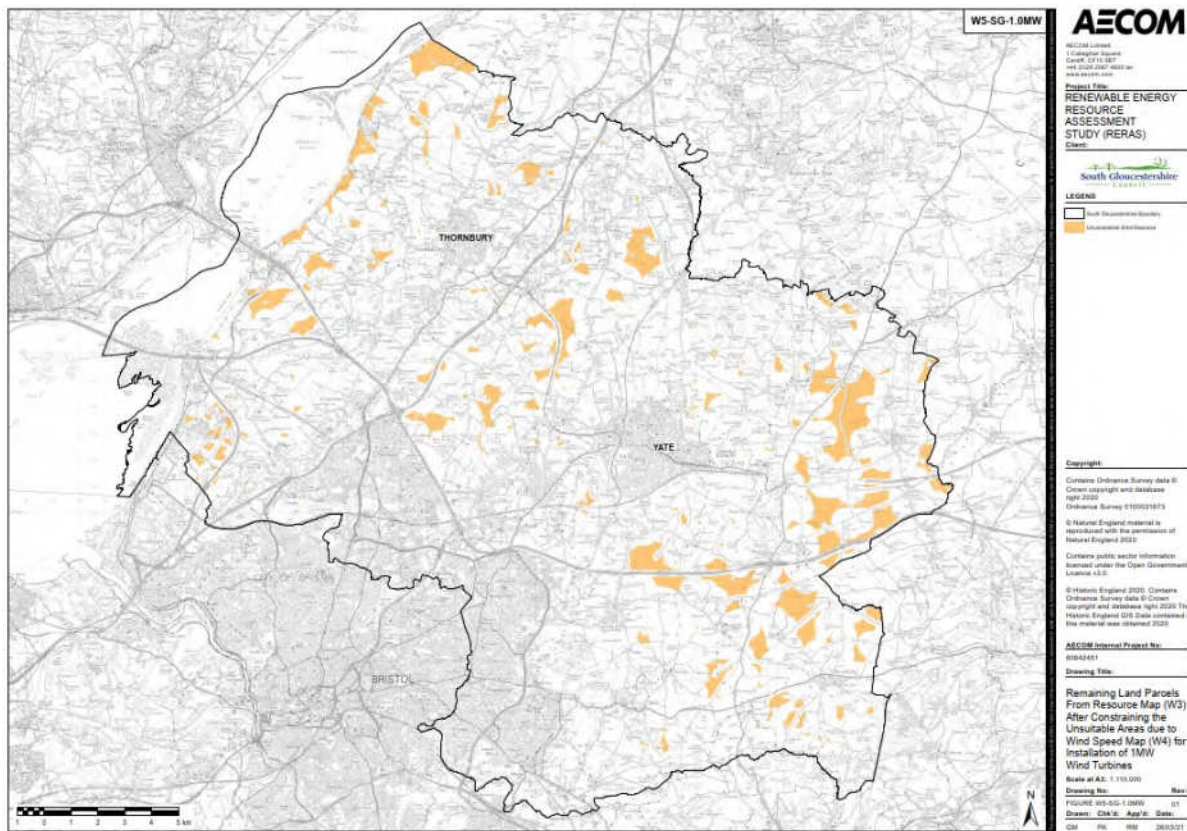

**Figure 84: W5-SG-1.0MW: Remaining Land Parcels from Resource Map (W3) After Constraining the Unsuitable Areas due to Wind Speed Map (W4) for Installation of 1MW Wind Turbines Map**

<sup>225</sup>Labelled as “Unconstrained Wind Resource” on W5 maps.  
Prepared for: South Gloucestershire Council

**Table 48: Remaining Land Available for Wind Turbines at this Stage of the Assessment and Potential Total Installed Capacity Based on the Available Area**

Map Reference	Note	Remaining Available Land Area (km <sup>2</sup> )	Potential Total Installed Capacity (MW) <sup>226</sup>
W5-SG-0.5MW	The remaining available area for 500kW wind turbines at this stage of the assessment	58.85	One turbine to be sited in each identified area.
W5-SG-1.0MW	The remaining available area for 1.0MW wind turbines at this stage of the assessment	31.49	251.92
W5-SG-2.5MW	The remaining available area for 2.5MW wind turbines at this stage of the assessment	18.97	170.73

**Step 6: Identification of Wind Search Areas and Maximum Available Wind Resource**

Map References & Titles:

1. W6-SG-500kW: Remaining Land Parcels from W5 Map for 500kW Wind Turbines After Constraining Land Slivers, Fire Breaks and Tracks, As Well As Parcels of Land Allocated to 1.0MW and 2.5MW Wind Turbines
2. W6-SG-1.0MW: Remaining Land Parcels from W5 Map After Constraining Land Slivers, Fire Breaks and Tracks, As Well As Parcels of Land Insufficient to Support a Wind Farm of 5MW or More Based on 1.0 MW Wind Turbines
3. W6-SG-2.5MW: Remaining Land Parcels from W5 Map After Constraining Land Slivers, Fire Breaks and Tracks, As Well As Parcels of Land Insufficient to Support a Wind Farm of 5MW or More Based on 2.5MW Wind Turbines

At this stage of the assessment, land slivers, fire breaks and tracks, as well as parcels of land insufficient to support a wind farm of 5MW or more, were removed from the Step 5 maps.

Additionally, suitable areas for 1.0MW and 2.5MW turbines were removed from the 500kW turbine maps.

A higher resolution version of this map is contained in the accompanying document 'South Gloucestershire RERAS – Maps'.

<sup>226</sup> It should be noted the areas for different wind turbines areas overlap and therefore the maximum potentials in this table cannot be added together.

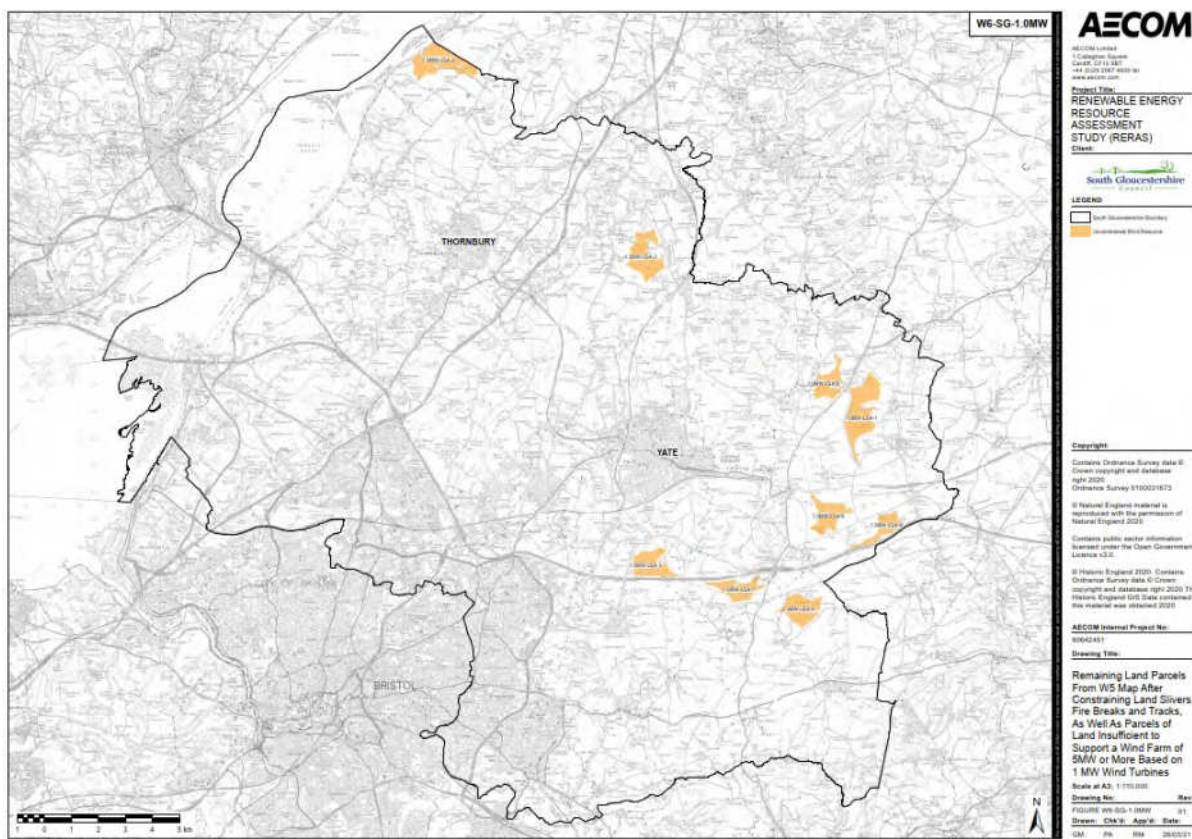

**Figure 85: W6-SG-1.0MW: Remaining Land Parcels from W5 Map After Constraining Land Slivers, Fire Breaks and Tracks, As Well As Parcels of Land Insufficient to Support a Wind Farm of 5MW or More Based on 1.0 MW Wind Turbines Map**

### Maximum Available Wind Resource

Following Steps 1 to 5, the remaining areas define the initial Search Areas (SAs) for wind development in South Gloucestershire. Where there was a minor road, major road, or any of the constraints mentioned above that separate the identified locations, SAs were defined for each site independently.

The total remaining potential wind resource<sup>227</sup> informed the calculation of the total potential capacity and informed renewable energy generation aims of South Gloucestershire.

Table 49 below shows the remaining area for wind development at this stage and its potential total installed capacity. The 1.0MW and 2.5MW capacity figures are not cumulative; it was assumed that either all the turbines in these areas would be 1MW turbines or all would be 2.5MW turbines. In reality, a mixture of scales could be deployed. Assuming that a wind turbine will generate energy at peak for 25% of the time (2,190 hours) over the course of a year, the total potential energy (GWh) was calculated<sup>228</sup>.

<sup>227</sup> Labelled as “Unconstrained Wind Resource” on W6 maps

<sup>228</sup> Average of the five previous years’ regional standard load factors published by BEIS.

**Table 49: Identified Wind SAs in South Gloucestershire and Theoretical Maximum Potential Wind Resource**

Map Reference	Note	Remaining Available Land Area (km <sup>2</sup> )	Potential Total Installed Capacity (MW)	Potential Total Electricity Generation (GWh)
W6-SG-0.5MW	SAs for 500kW wind turbines in South Gloucestershire	43.75	286.5 <sup>229</sup>	623.60
W6-SG-1.0MW	SAs for 1.0MW wind turbines in South Gloucestershire	10.77	86.13	187.54
W6-SG-2.5MW	SAs for 2.5MW wind turbines in South Gloucestershire	8.13	73.17	159.26
Total			392.49 <sup>230</sup>	854.31

**Policy Recommendation****Policy Reference: WF-PR-5 (Refer to Table 39 in Section 17)**

It is recommended that the SAs identified through the RERAS for 1MW and 2.5MW turbines are further refined and safeguarded through the Local Plan process.

The remaining land available and potential installed capacity for each of the 1.0MW and 2.5MW Search Areas are shown in Table 50 and Table 51 respectively.

**Table 50: Individual Identified 1.0MW Wind SA's in South Gloucestershire and Their Theoretical Maximum Potential Installed Capacity**

SA Reference on Maps	SA Area (km <sup>2</sup> )	Potential Total Installed Capacity (MW) <sup>231</sup>
1.0MW-1	1.946	15.57
1.0MW-2	1.709	13.67
1.0MW-3	1.377	11.01
1.0MW-4	1.147	9.18
1.0MW-5	1.119	8.95
1.0MW-6	1.053	8.43
1.0MW-7	0.884	7.07
1.0MW-8	0.815	6.52
1.0MW-9	0.719	5.75

**Table 51: Individual Identified 2.5MW Wind SA's in South Gloucestershire and Their Theoretical Maximum Potential Installed Capacity**

SA Reference on Maps	SA Area (km <sup>2</sup> )	Potential Total Installed Capacity (MW) <sup>87</sup>
2.5MW-1	1.646	14.81
2.5MW-2	1.456	13.10
2.5MW-3	1.355	12.20
2.5MW-4	0.948	8.54
2.5MW-5	0.796	7.16
2.5MW-6	0.767	6.90
2.5MW-7	0.601	5.41
2.5MW-8	0.561	5.05

<sup>229</sup> 573 additional small land parcels for 500kW turbine installations have been identified. It is assumed that one 500 kW turbine could be sited on each.

<sup>230</sup> The potential from 1.0MW and 2.5MW search areas cannot be added together as some of the areas overlap. The maximum capacity in this table is taken from 1.0MW search areas plus and additional non-overlapping 2.5MW search areas.

<sup>231</sup> Potential total installed capacities are calculated using density factors provided in Table 9 (rounded figures).



## Step 7: Combined Wind Search Areas in South Gloucestershire

Map Reference & Title:

1. W7-SG: Combined Wind Search Areas in South Gloucestershire

Areas of constraint have been applied through mapping to identify the potentially suitable locations<sup>232</sup> for the development of wind farms, and these are labelled as wind farm Search Areas.

### Policy Recommendation

#### Policy Reference: WF-PR-1 (Refer to Table 39 in Section 17)

It is recommended that the SAs identified through the RERAS are further refined through the Local Plan process, taking account of other considerations and constraints.

### Policy Recommendation

#### Policy Reference: WF-PR-2 (Refer to Table 39 in Section 17)

It is recommended that proposals for wind turbines of the appropriate number and size (to make the most efficient use of the resource/ land) benefit from a presumption in favour of wind development when located within the areas identified for that use through the Local Plan.

W7-SG map illustrates the identified wind Search Areas (SAs) for each of the three wind turbine sizes, the 500kW SAs are coloured orange, the 1.0MW SAs blue striped and the 2.5MW SAs in pink. There were 573, 9 and 8 SAs identified for 500kW, 1.0MW and 2.5MW turbines, respectively. The SAs are referenced based on their corresponding wind turbine size and prioritised based on size (largest), e.g. 1.0MW-LSA-1 is the largest SA suitable for 1.0MW wind turbines installations. It was assumed that one 500kW turbine would be situated on each SA identified as suitable for a 500kW turbine.

This RERAS is primarily concerned with identifying potential wind development opportunities larger than 5MW, utilising 1.0MW and 2.5MW wind turbines as the basis for constraints mapping. The small scale SAs suitable for 500kW or smaller turbines are identified in the interest of completeness, and their potential is considered in the aim setting section of this study, Section 15.

### Policy Recommendation

#### Policy Reference: WF-PR-3 (Refer to Table 39 in Section 17)

It is recommended that proposals for wind turbines >2.5MW within the areas identified through the Local Plan will benefit from a presumption in favour of wind development, subject to compliance with the primary constraints listed in Section 4.2.1 (e.g. noise, topple distances) and consideration of other site-specific issues and constraints.

### Policy Recommendation

#### Policy Reference: WF-PR-4 (Refer to Table 39 in Section 17)

It is recommended that proposals for wind turbines outside of areas identified as suitable for wind development through the Local Plan should be considered positively, providing it can demonstrate that proposals are compliant with relevant policy and site-specific issues and constraints can be mitigated to the satisfaction of the Council.

A higher resolution version of this map is contained in the accompanying document 'South Gloucestershire RERAS – Maps'.

<sup>232</sup>Labelled as "Unconstrained Wind Resource" on W7 map.  
Prepared for: South Gloucestershire Council

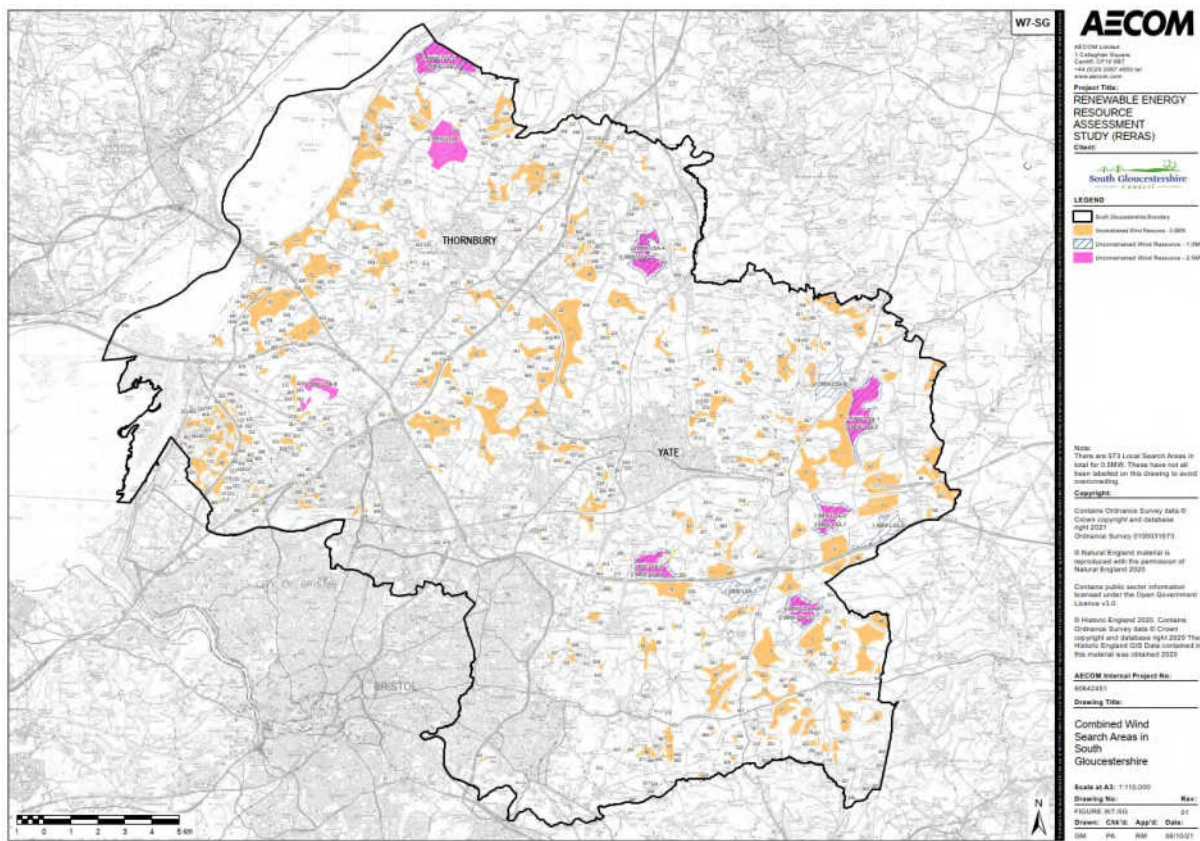

**Figure 86: W7-SG: Combined Wind Search Areas in South Gloucestershire Map**

A total of 43.75km<sup>2</sup>, 10.77 km<sup>2</sup> and 8.13 km<sup>2</sup> of land was identified as being potentially suitable for the installation of a 500kW, 1.0MW and 2.5MW wind turbines respectively. These areas comprise large parts of rural South Gloucestershire, as can be seen in Figure 86. It should be noted these search areas will need to be refined further through the Local Plan process, taking into account other considerations and constraints, as part of developing a strategy for renewable energy development.

**Policy Recommendation**

**Policy Reference: WF-PR-9 (Refer to Table 39 in Section 17)**

It is recommended that proposals for wind turbines at the former Oldbury Power Station site will, subject to compliance with noise, topple-distance, site-specific constraints and other policy considerations should be looked upon favourably.

**Policy Recommendation**

**Policy Reference: WF-PR-5 (Refer to Table 39 in Section 17)**

It is recommended that the SAs identified through the RERAS for 1MW and 2.5MW turbines are further refined and safeguarded through the Local Plan process.

**Policy Recommendation**

**Policy Reference: WF-PR-7 (Refer to Table 39 in Section 17)**

It is recommended that proposals for wind development within areas identified through the Local Plan for 1 and 2.5MW turbines maximise the potential resource. Where this is not the case, applicants should provide evidence as to why this is not feasible or viable.

## Step 8: Wind Resource Other Constraints to Consider Further

Map References & Titles:

1. W8-SG-0.5MW: Wind Resource Other Constraints – to Consider Further
2. W8-SG-1.0MW: Wind Resource Other Constraints – to Consider Further
3. W8-SG-2.5MW: Wind Resource Other Constraints – to Consider Further

Effects of other constraints that may impact wind development within the SAs were analysed in this section of the study. However, it was agreed that these constraints would need to be examined as part of the Local Plan process and therefore, the identified SAs in mapping Step 6 have not been constrained further in this assessment.

W8 maps illustrate the following other constraints.

- Other woodlands (Other than Broadleaved Woodland and Ancient Woodland);
- Area of Outstanding Natural Beauty (AONB);
- Natural England's Impact Risk Zones for Wind Development (IRZs);
- Unlicensed Aerodromes;
- Minerals Safeguarding Areas;
- National Air Traffic Control Services (NATS) Radar Safeguarding Areas;
- Aviation Safeguarded Zone;
- Flood Zones;
- National Trust Inalienable Land;
- Green Belt<sup>233</sup>;
- MoD Safeguarding Zones;
- Historic England Conservation Areas; and
- Consented (but not yet constructed) solar PV and wind developments where their planning permissions may have lapsed.

A higher resolution version of this map is contained in the accompanying document 'South Gloucestershire RERAS – Maps'.

---

<sup>233</sup> As stated in the NPPF, paragraph 151: 'When located in the Green Belt, elements of many renewable energy projects will comprise inappropriate development. In such cases developers will need to demonstrate very special circumstances if projects are to proceed. Such very special circumstances may include the wider environmental benefits associated with increased production of energy from renewable sources'

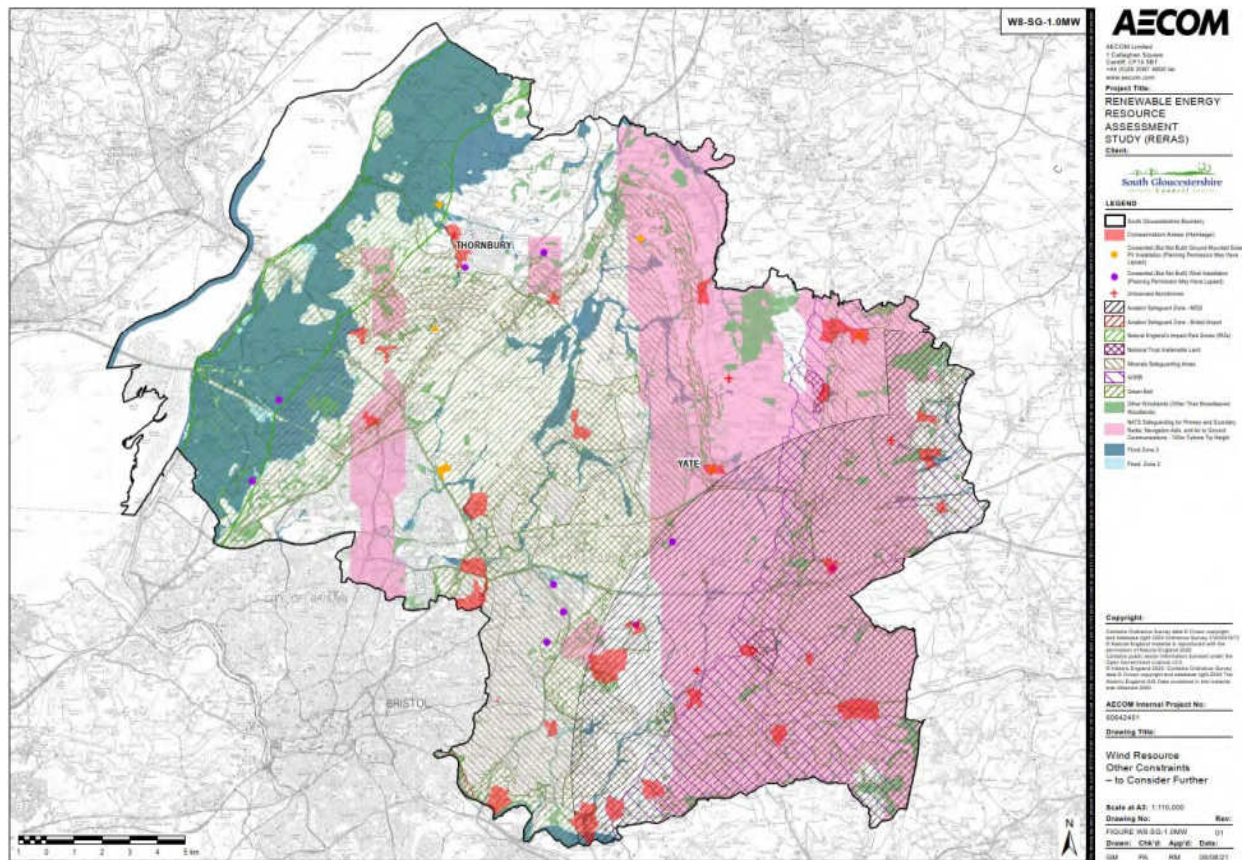

Figure 87: W8-SG-1.0MW: Wind Resource Other Constraints – to Consider Further Map

### Step 9: Remaining Area of Local Search Areas after Applying Selected Additional Constraints

Map References & Titles:

1. W9-SG: Wind Local Search Areas from W7 Map and Natural England’s Wind Impact Risk Zones (IRZs) in South Gloucestershire
2. W10-SG: Wind Local Search Areas from W7 Map and Areas of Outstanding Natural Beauty (AONB) in South Gloucestershire
3. W11-SG: Wind Local Search Areas from W7 Map and Flood Zones in South Gloucestershire
4. W12-SG: Wind Local Search Areas from W7 Map and Green Belt Area in South Gloucestershire

The additional maps in this section of the study overlay the following other constraints on the identified wind Search Areas in Step 6 for illustrative purposes only. Table 52 provides further information regarding each map’s remaining area and potential capacity if the overlapping areas covering these constraints and SAs were removed.

- Natural England’s Impact Risk Zones for Wind Development (IRZs);
- Area of Outstanding Natural Beauty (AONB);
- Flood Zones;
- Green Belt.

Higher resolution versions of these maps are contained in the accompanying document ‘South Gloucestershire RERAS – Maps’.

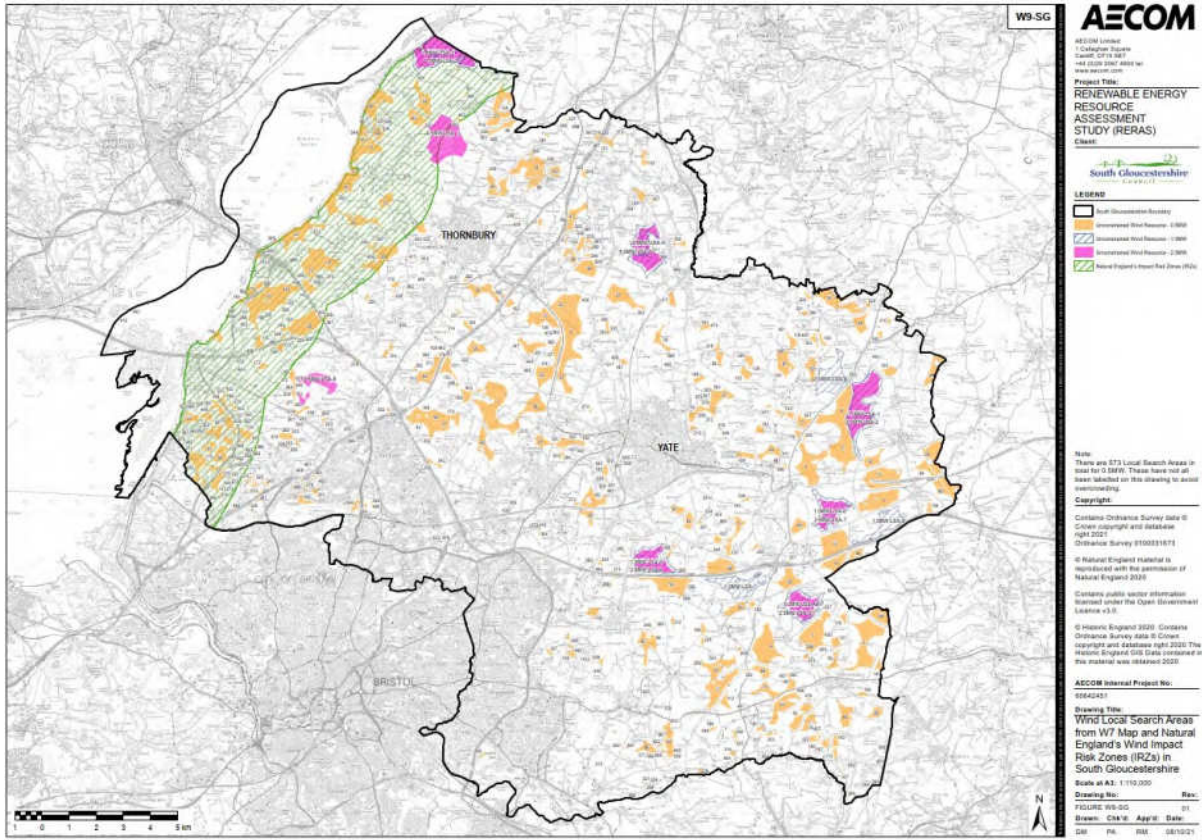

Figure 88: W9-SG: Wind Local Search Areas from W7 Map and Natural England's Wind Impact Risk Zones (IRZs) in South Gloucestershire Map

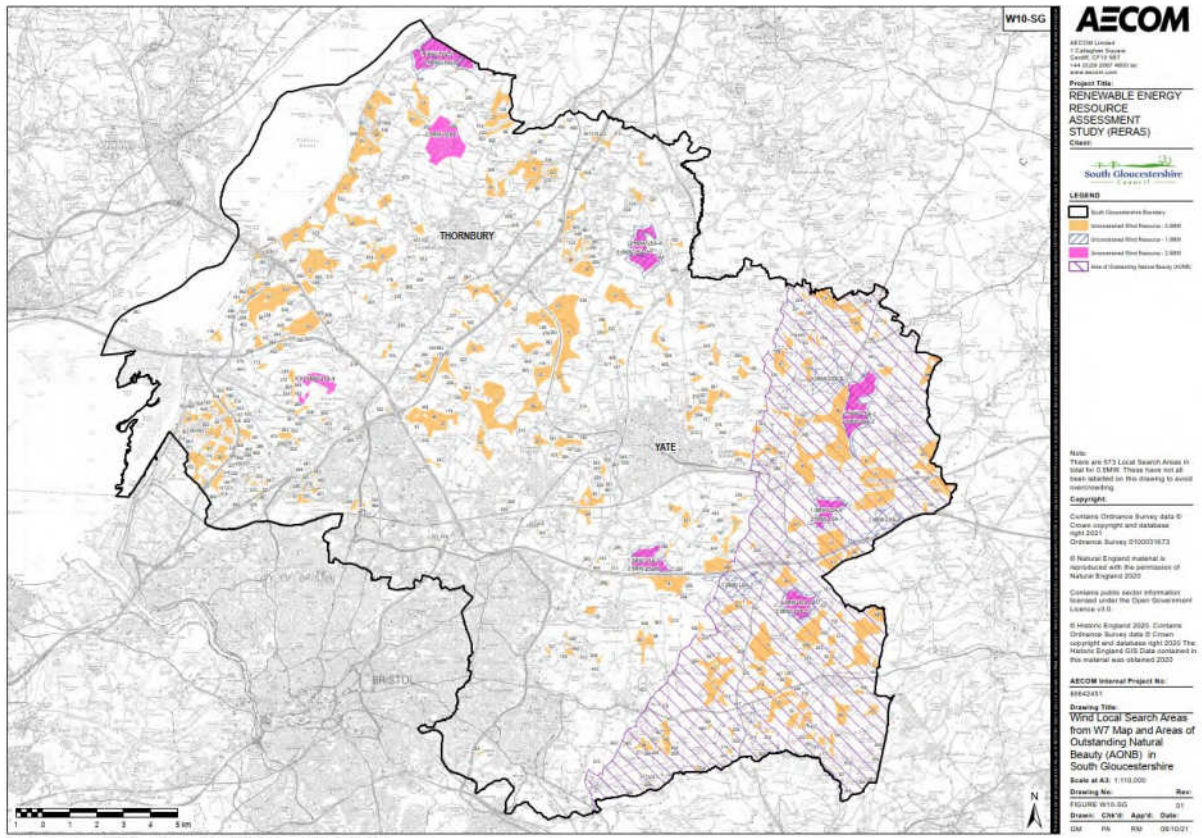

Figure 89: W10-SG: Wind Local Search Areas from W7 Map and Areas of Outstanding Natural Beauty (AONB) in South Gloucestershire Map

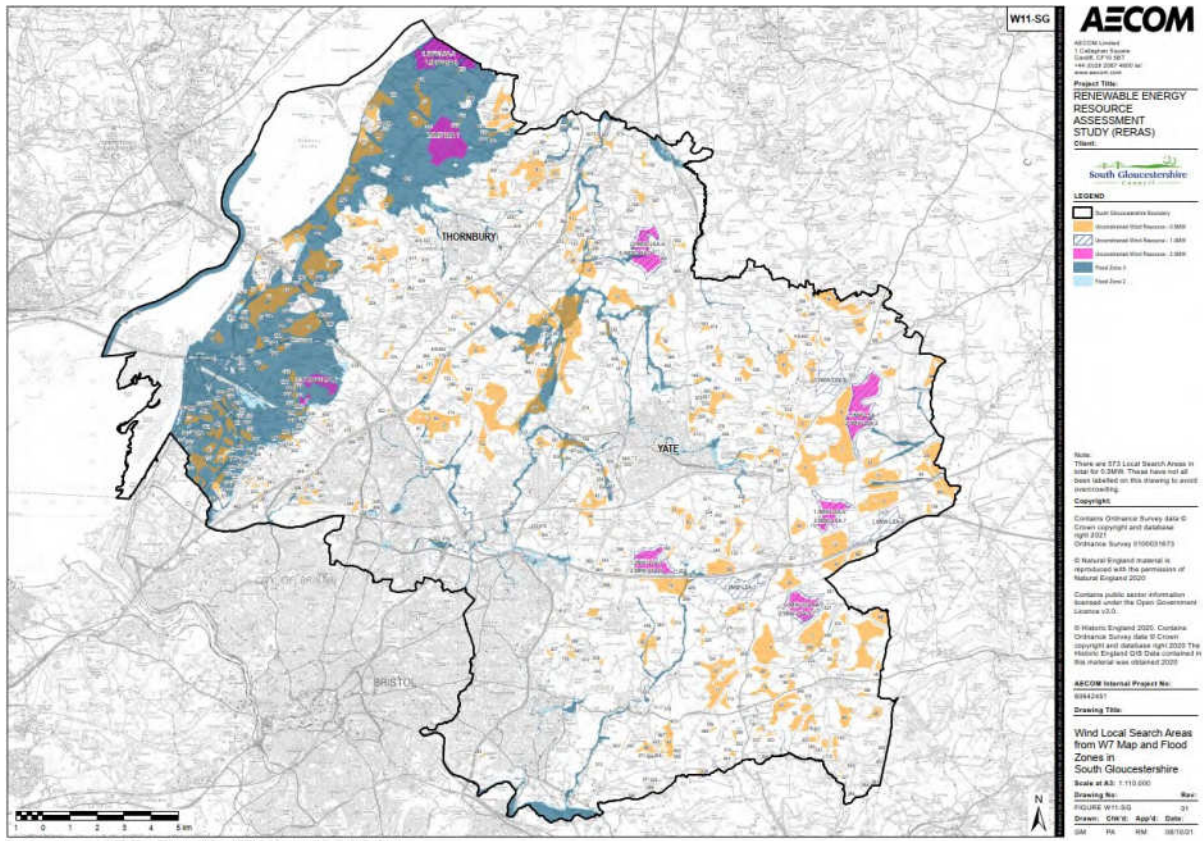

Figure 90: W11-SG: Wind Local Search Areas from W7 Map and Flood Zones in South Gloucestershire Map

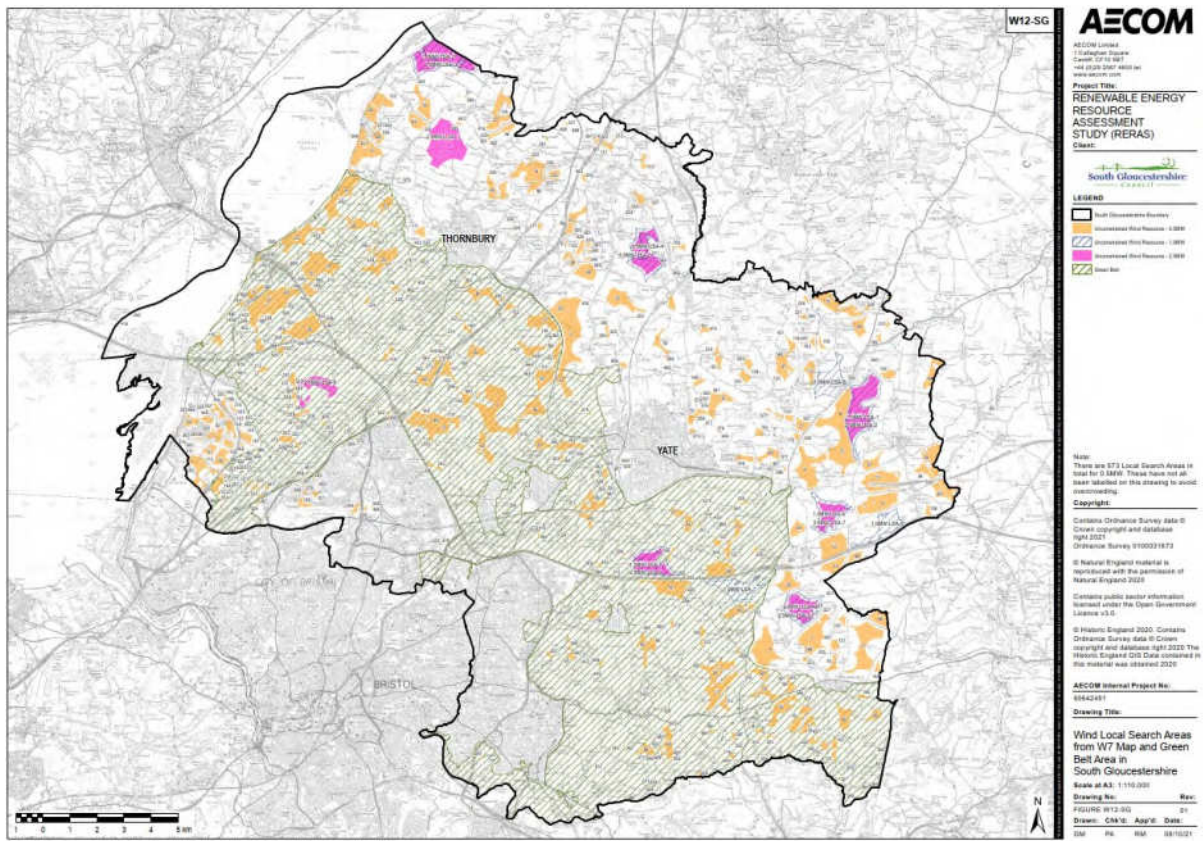

Figure 91: W12-SG: Wind Local Search Areas from W7 Map and Green Belt Area in South Gloucestershire Map

**Table 52: Remaining Area of SAs After Applying Selected Other Constraints for Illustrative Purposes Only**

Map Reference	Notes	Other Constraint Shown on the Map	Area of the Final Wind SAs Identified in Step 6 (km <sup>2</sup> )	Potential Installed Capacity of the Final Wind SAs (MW)	Remaining SAs if Area of the Other Constraint Is Removed (km <sup>2</sup> )	Remaining Potential Installed Capacity of the SAs if Area of the Other Constraint Is Removed (MW)
W9-SG	500kW Turbines SAs	Natural England's IRZs for Wind	43.75	286.5 <sup>234</sup>	34.48	219
W9-SG	1.0MW Turbines SAs	Natural England's IRZs for Wind	10.77	86.13	9.12	72.96
W9-SG	2.5MW Turbines SAs	Natural England's IRZs for Wind	8.13	73.17	6.09	54.81
W10-SG	500kW Turbines SAs	AONB	43.75	286.5	26.91	218
W10-SG	1.0MW Turbines SAs	AONB	10.77	86.13	4.3	34.4
W10-SG	2.5MW Turbines SAs	AONB	8.13	73.17	5.28	47.52
W11-SG	500kW Turbines SAs	Flood Zones	43.75	286.5	32.94	198
W11-SG	1.0MW Turbines SAs	Flood Zones	10.77	86.13	8.89	71.12
W11-SG	2.5MW Turbines SAs	Flood Zones	8.13	73.17	4.49	40.41
W12-SG	500kW Turbines SAs	Green Belt	43.75	286.5	23.66	141.5
W12-SG	1.0MW Turbines SAs	Green Belt	10.77	86.13	8.77	70.16
W12-SG	2.5MW Turbines SAs	Green Belt	8.13	73.17	6.8	61.2

<sup>234</sup> It is assumed that one 500 kW turbine could be sited on each.  
Prepared for: South Gloucestershire Council

## Wind SAs and MOD and Aviation Safeguarded Areas.

### Map References & Titles:

1. W13-SG-0.5MW: Wind Local Search Areas for 500kW Turbines from W6 Map and MOD, NATS and Aviation Safeguarded Zones
2. W13-SG-1.0MW: Wind Local Search Areas for 1.0MW Turbines from W6 Map and MOD, NATS and Aviation Safeguarded Zones
3. W13-SG-2.5MW: Wind Local Search Areas for 2.5MW Turbines from W6 Map and MOD, NATS and Aviation Safeguarded Zones

Considering the risks of interference with radar and the impact of proposed wind turbine developments on aviation operations must be considered on a case-by-case basis. Therefore, it was agreed not to add these constraints for unlicensed aerodromes in this study. However, the W13 maps are prepared to spatially indicate radar, MoD and aviation safeguarding areas and to assist developers and the Council with any dialogue/that consultation that may be required with these organisations in relation to wind turbine installations. It should be noted these maps are for information only, and these restrictions must be considered in more detail in the planning process. A higher resolution version of this map is contained in the accompanying document 'South Gloucestershire RERAS – Maps'.

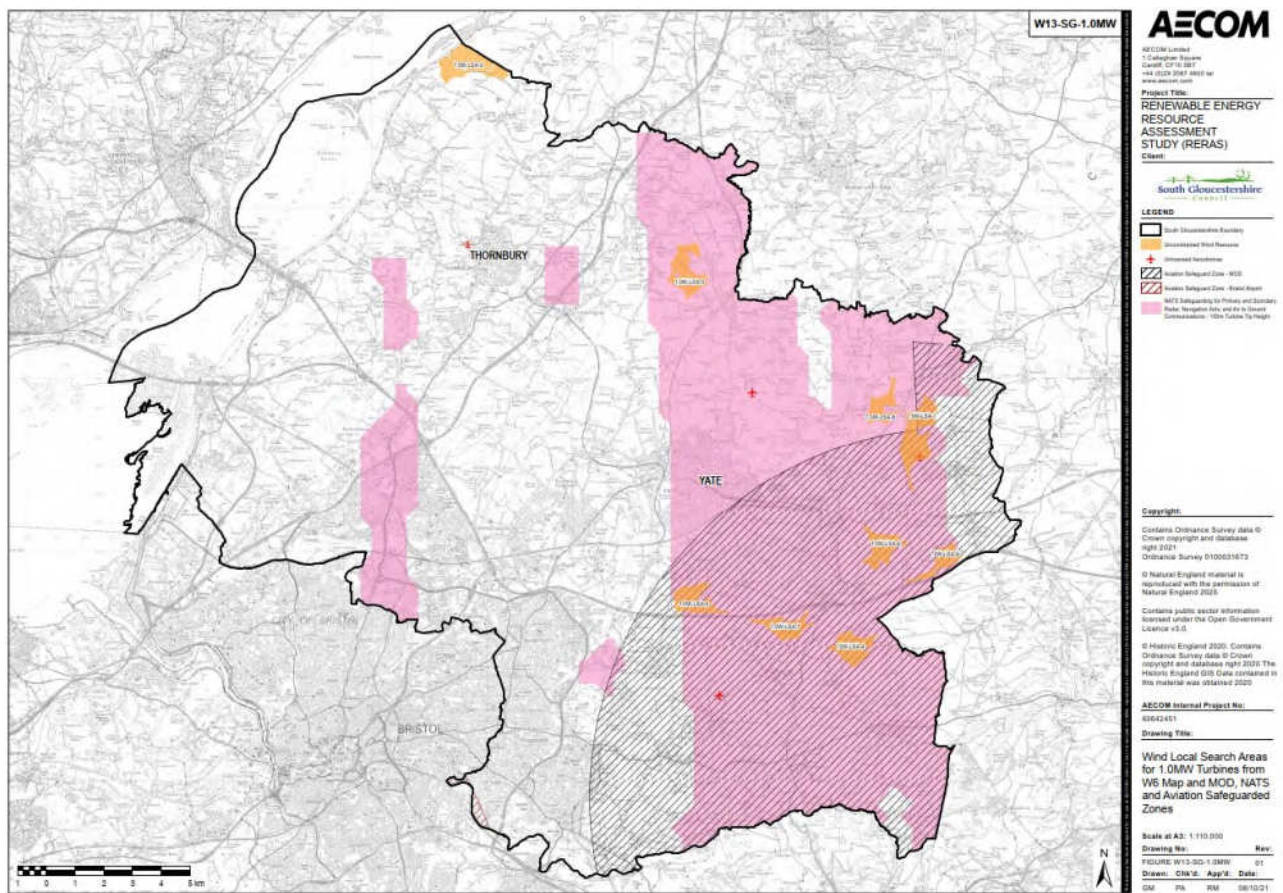

**Figure 92: W13-SG-1.0MW: Wind Local Search Areas for 1.0MW Turbines from W6 Map and MOD, NATS and Aviation Safeguarded Zones<sup>235</sup>**

<sup>235</sup> The W13 Maps for 500kW and 2.5MW turbines can be found in the accompanying document 'South Gloucestershire Renewable Energy Resource Assessment Study – Maps'.  
Prepared for: South Gloucestershire Council



## Wind SAs and Conservation Areas (Heritage)

### Map Reference & Title

1. W14-SG: Combined Wind Search Areas and Conservation Areas (Heritage) in South Gloucestershire

In England, the planning authorities are obliged to designate as conservation areas any parts of their own area that are of special architectural or historic interest, the character and appearance of which it is desirable to preserve or enhance. Under the National Planning Policy Framework (NPPF) conservation areas are designated heritage assets and their conservation is to be given weight in planning permission decisions<sup>236</sup>. Therefore, the W14 map is prepared that shows the location of the Conservation Areas in relation to the SAs to assist the Council and developers when considering renewable energy proposals. A higher resolution version of this map is contained in the accompanying document 'South Gloucestershire RERAS – Maps'.

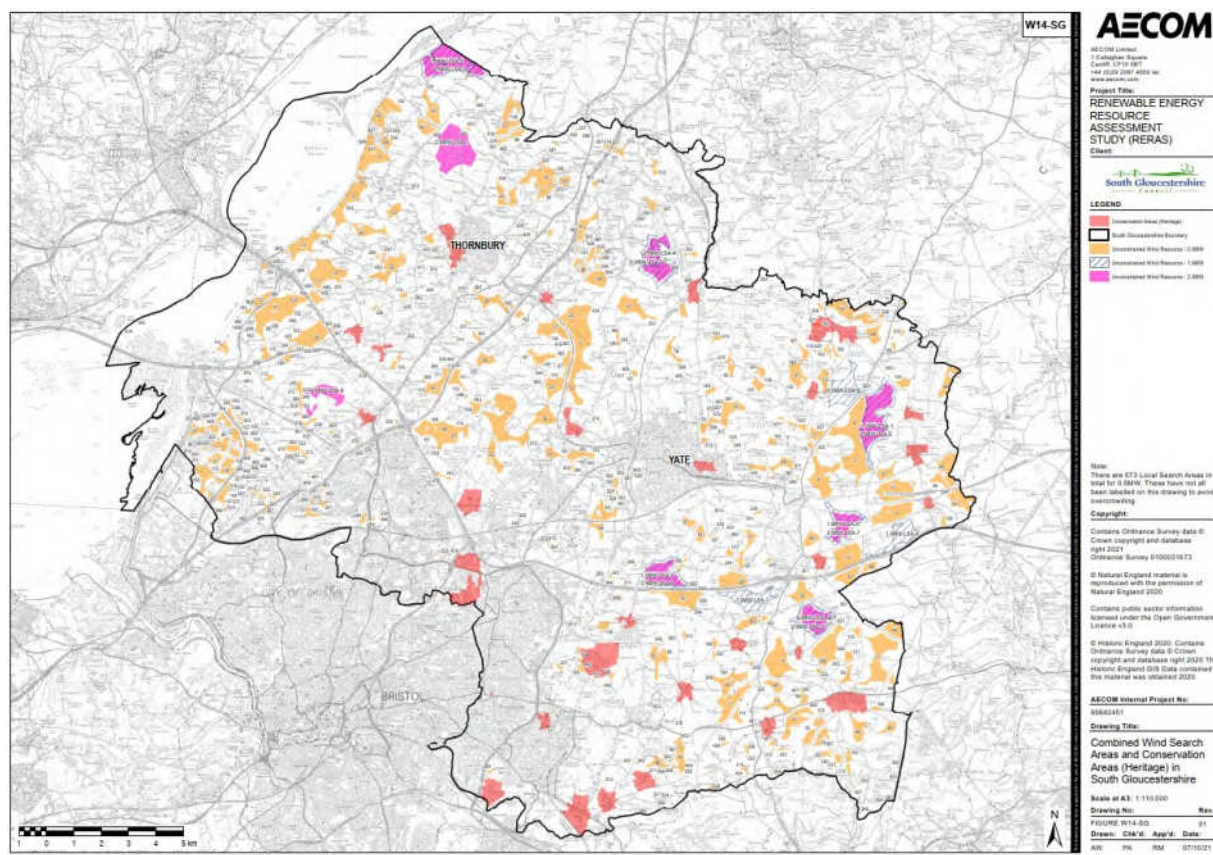

**Figure 93 W14-SG: Combined Wind Search Areas and Conservation Areas (Heritage) in South Gloucestershire**

### Buffer Zones for Local Search Areas

#### Map References & Titles:

1. W15-SG-0.5MW: Buffer Zones for Wind Local Search Areas from 500kW Turbines
2. W15-SG-1.0MW: Buffer Zones for Wind Local Search Areas from 1.0MW Turbines
3. W15-SG-2.5MW: Buffer Zones for Wind Local Search Areas from 2.5MW Turbines

The final SAs are mapped separately for each of the turbine sizes. A buffer corresponding to each turbine size (see Table 45) was applied to the defined SAs to ensure safety requirements are incorporated in future developments. A higher resolution version of this map is contained in the accompanying document 'South Gloucestershire RERAS – Maps'.

<sup>236</sup> <https://historicengland.org.uk/advice/hpg/has/conservation-areas/>  
 Prepared for: South Gloucestershire Council

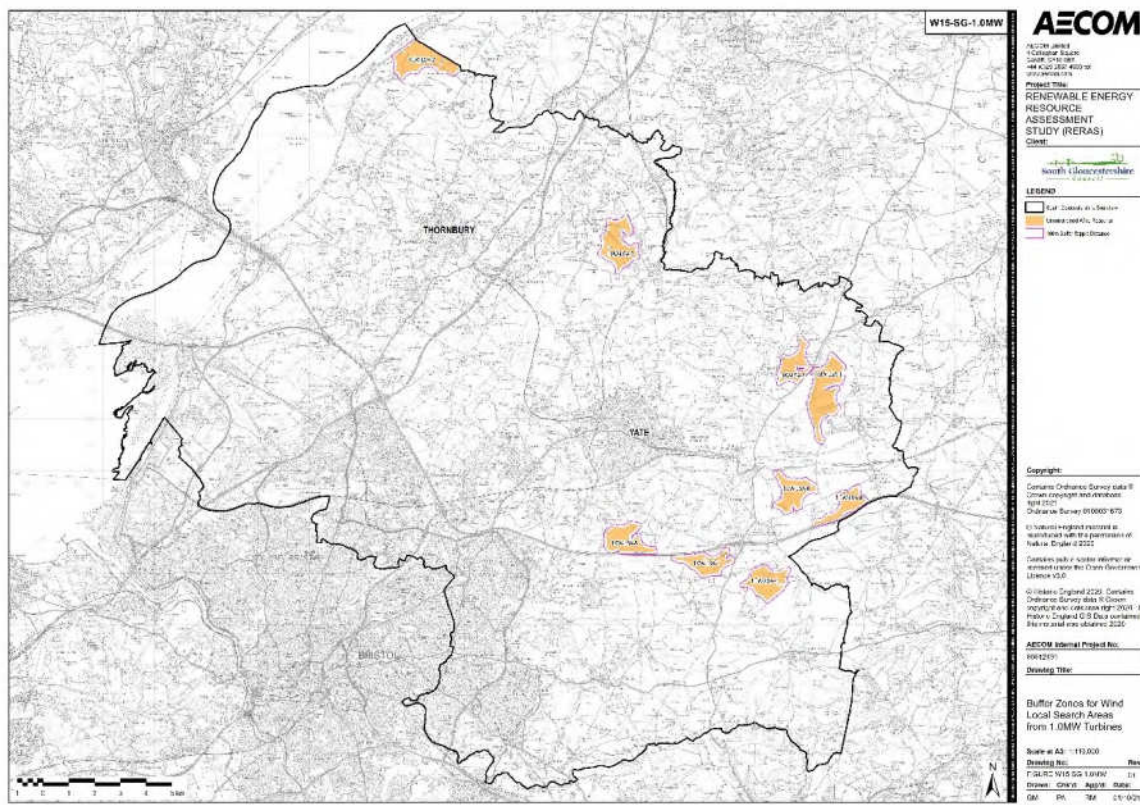

**Figure 94: W15-SG-1.0MW: Buffer Zone for Wind Local Search Areas from 1.0MW Turbines Map**

**Policy Recommendation**

**Policy Reference: WF-PR-6 (Refer to Table 39 in Section 17)**

It is recommended that policy measures (e.g. safeguarding) are put in place to ensure that the areas identified for wind development through the Local Plan are not sterilised by non-wind development.

### E.3 Pipeline Projects and Repowering Consideration

In this section of the report, data from Regen’s Distribution Future Energy Scenarios (DFES) analysis was utilised to identify the pipeline wind projects and assess the repowering potential of existing wind energy installations to increase their capacity. Project readiness of the identified SAs in relation to the current grid capacity and costs of grid upgrades are considered in E.4.

The methodology used for pipeline analysis and repowering assumptions in Regen’s DFES analysis is provided below.

The starting point for the pipeline analysis for wind farms was the Distribution Network Operator’s (DNO’s) list of projects with an accepted grid connection offer but have not yet progressed further than that. In Western Power Distribution’s (WPD) licence areas, the majority of such sites have accepted a connection offer in the last few years.

The stage of development for these pipeline sites was then assessed through stakeholder and industry engagement and discussion with the developers directly, where possible. The planning stage is another key factor that influences the rate at which sites connect to the electricity network; this factor tends to be of greater importance for wind farms than solar projects. Regen assumes that sites without evidence of recent activity or planning permission do not connect in the near term. It should be noted that any site with current planning permission is shown and constrained on W2 maps as consented (but not yet constructed) developments.

Additionally, an assumption was made that all wind farms at the end of their operational life are replaced with new turbines of either the same capacity or larger. Regen research showed that there is evidence from ‘repowering events’ to date of a large increase in capacity, sometimes doubling the initial capacity of the wind farm. The repowering assumptions in the WPD DFES 2020 were varied by scenario, but also by the age and size of a wind farm:

- Older sites with smaller capacity turbines were assumed to take advantage of improvements in technology to increase their capacity;
- Very small sites and domestic scale turbines were assumed to be replaced at the same capacity level.

WPD DFES 2020 includes four different scenarios which are summarised below<sup>237</sup>.

### 1. Steady Progression

- Low levels of decarbonisation and societal change.
- Not compliant with the 2050 net zero emissions target.

### 2. System Transformation

- High level of decarbonisation with lower societal change. Larger, more centralised solutions are developed. This scenario has the highest levels of hydrogen deployment.

### 3. Consumer Transformation

- High levels of decarbonisation and societal change. Consumers adopt new technologies rapidly, and more decentralised solutions are developed. This scenario has significant electrification of domestic heat.

### 4. Leading the Way

- Very high levels of decarbonisation and societal change. Consumers adopt new technologies rapidly, and a mix of solutions are developed. This scenario aims for the “fastest credible” decarbonisation pathway

Therefore, as a result, the analysis and repowering potential of the existing Alveston Wind Park are provided in Table 53. No pipeline projects in relation to wind development have been identified in South Gloucestershire.

**Table 53: Repowering Capacity of the Existing Wind Farm in South Gloucestershire**

Site	Existing Capacity (MW)	WPD DFES Scenario	Repower Data	Repower Capacity (MW)
Alveston Wind Park	6.9	Steady Progression	2047	8.6
Alveston Wind Park	6.9	System Transformation	2042	8.6
Alveston Wind Park	6.9	Consumer Transformation	2037	10.4
Alveston Wind Park	6.9	Leading the Way	2037	9.2

## E.4 Proximity to Grid and Grid Capacity

Map References & Titles:

1. W16-SG-1.0MW - 1.0MW Wind Search Areas and Grid Connection
2. W16-SG-2.5MW – 2.5MW Wind Search Areas and Grid Connection

Whilst private wire schemes are an option, and some already exist in the UK, onshore wind farms usually have a connection to the grid to export electricity, albeit with increasing curtailments.

Consideration of a viable connection point is an important factor when considering sites for new wind energy development. The cost of a grid connection depends on the distance to the nearest

<sup>237</sup> <https://www.westernpower.co.uk/downloads-view-reciteme/228118>

connection point the works needed to make that connection (there can be a number of complexities such as land ownership issues, whether the dig is hard or soft, etc) and the availability of capacity in the distribution network to take the additional power output. For this study, grid connection is assumed to be a discussion matter for national-level decision-makers and has not been used to constrain wind energy generation potential. In addition, as renewable deployment is a national priority, it is assumed that the grid requirement will be met to allow for sufficient additional capacity.

However, a high-level analysis exercise has been undertaken in consultation with the Distribution Network Operator, Western Power Distribution (WPD), to rank the 1.0MW and 2.5MW SAs and assess their project readiness based on the network capacity maps and connection points at the time of writing. The Search Areas are ranked from low priority (coloured red in the maps) to high priority (coloured blue in the maps), with high priority being most favourable for a new grid connection, as shown in Figure 95 and Figure 96.

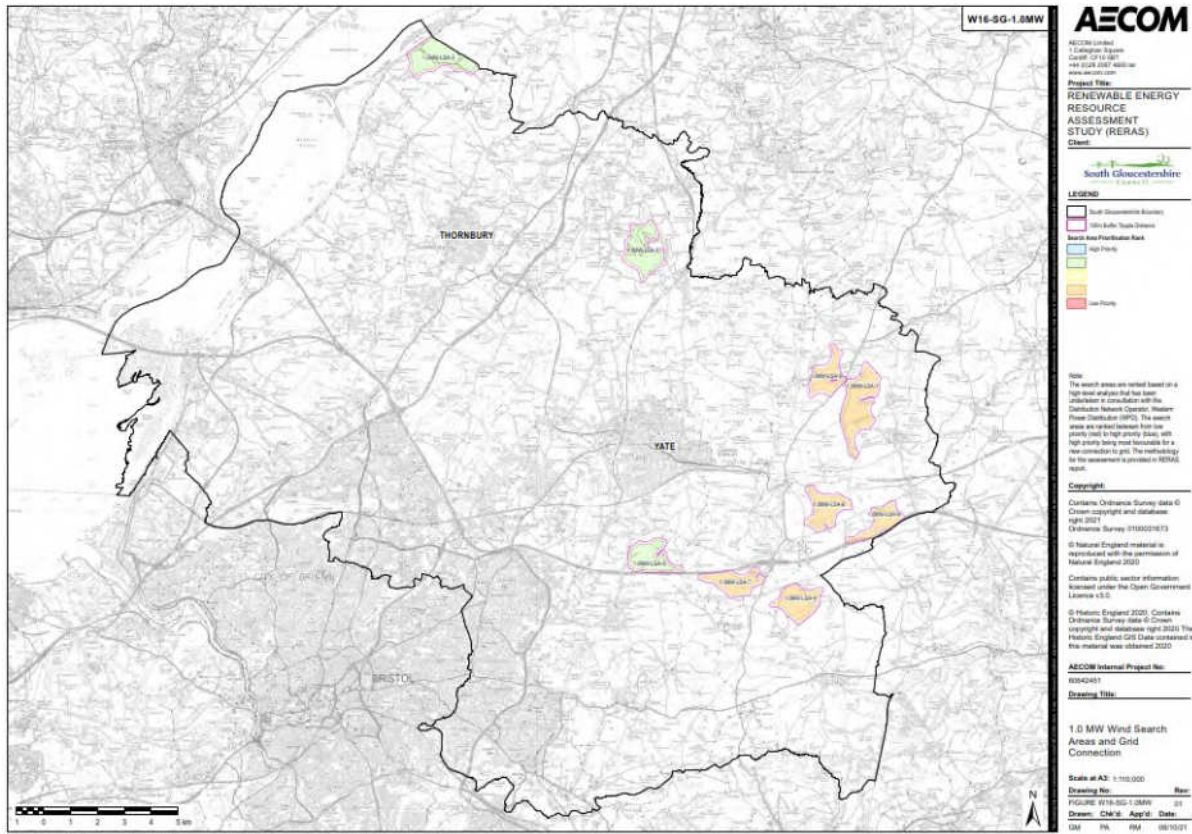

**Figure 95: SAs Proximity to Grid and Grid Capacity Ranking Key (Refer to map W16 in the Accompanying Document 'South Gloucestershire RERAS – Maps')**

This ranking has only been taken as a single snapshot based on the latest information. It does not account for any future reinforcement that may be triggered by other new connections or condition-based replacement. Increases or decreases in future demand may also affect capacity and have not been considered within this study. Sites over 1MW may be required to go through the Statement of Works process to confirm acceptance of the connection on the transmission network.

Network access may be accelerated or achieved with reduced costs by progressing an alternative connection, which allows export to be limited at times of high export from other users.

A higher resolution version of this map is contained in the accompanying document 'South Gloucestershire RERAS – Maps'.



**Figure 96: W16-SG-1.0MW: 1.0MW Wind Search Areas and Grid Connection in South Gloucestershire Map**

## E.5 Landscape Sensitivity Assessment

Map References & Titles:

1. W17-SG-500kW: Wind Local Search Areas for 500 kW Wind Turbines from W6 map and Landscape Sensitivity Results in Band C (61 to 100) in South Gloucestershire Map
2. W17-SG-1MW: Wind Local Search Areas for 1 MW Wind Turbines from W6 map and Landscape Sensitivity Results in Band D (101 to 120) in South Gloucestershire Map
3. W17-SG-2.5MW: Wind Local Search Areas for 2.5 MW Wind Turbines from W6 map and Landscape Sensitivity Results in Band E (121 to 150) in South Gloucestershire Map

An additional parameter that can be considered in ranking the Search Areas is Landscape Character Areas and the sensitivity of these landscapes to new wind farm development. A flowchart presenting the steps taken in completing mapping the results of a landscape sensitivity for wind farms is shown in Figure 97.

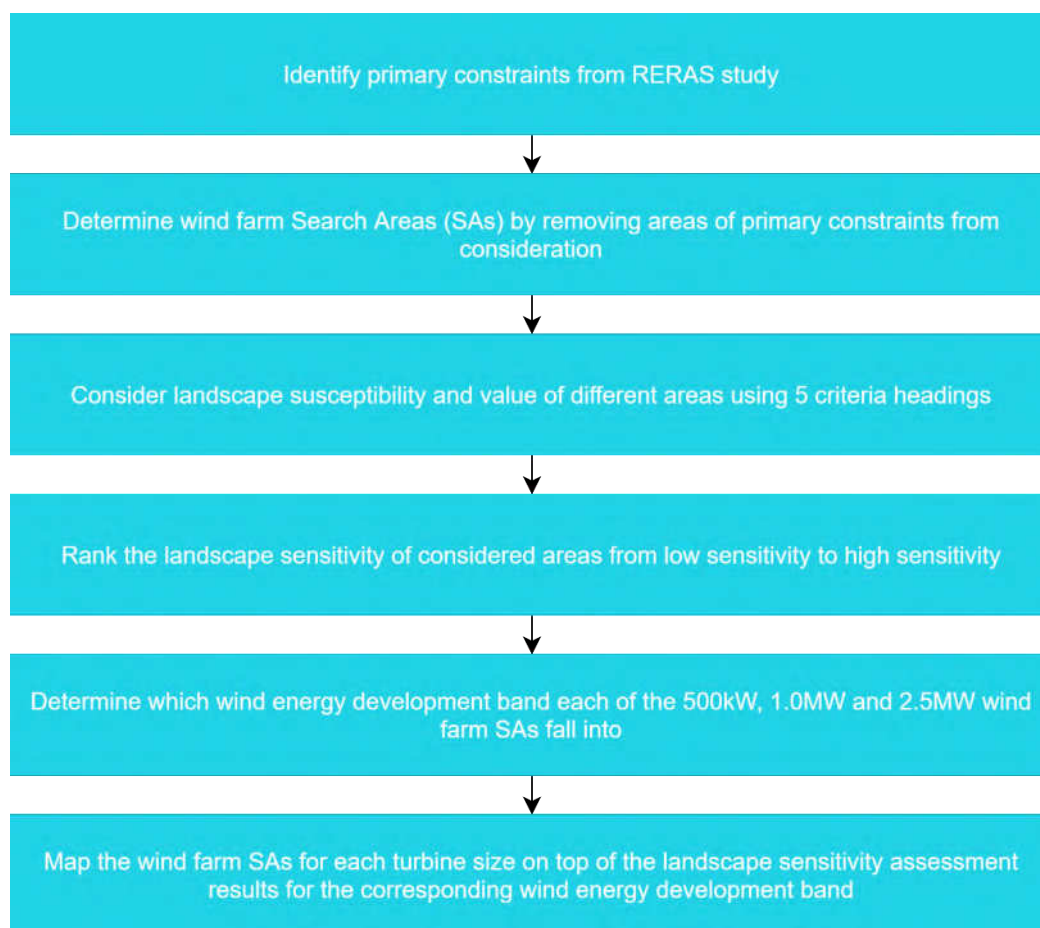

**Figure 97 Steps Taken in Landscape Sensitivity Study for Wind Farm Search Areas**

LUC has conducted a landscape sensitivity assessment for wind energy development as part of this RERAS. Results of the assessment provide an initial indication of the relative landscape sensitivity of different areas within South Gloucestershire to accommodate wind energy developments. The findings of the study, combined with the identified Search Areas, are presented in this section of the report. The landscape sensitivity assessment considers the landscape susceptibility<sup>238</sup> and landscape value<sup>239</sup> using 5 criteria headings:

- Landform and scale (including sense of openness / enclosure);
- Landcover (including field and settlement patterns);
- Historic landscape character;
- Visual character (including skylines); and
- Perceptual and scenic qualities.

Once the above criteria were assessed individually, the results were identified with an overall sensitivity level, as shown in Table 54.

<sup>238</sup> How vulnerable the landscape is to change from the type being assessed, in this case solar PV and wind energy developments

<sup>239</sup> Consensus about importance, which can be recognised through designation as well as through descriptions within the 2014 Landscape Character Assessment  
Prepared for: South Gloucestershire Council

**Table 54: The Five-Point Scale Landscape Sensitivity Scale**

Sensitivity Level	Definition
<b>High (H)</b>	Key characteristics and qualities of the landscape are highly vulnerable to change from wind and solar energy development. Such development is likely to result in a significant change in character.
<b>Moderate - High (M-H)</b>	Key characteristics and qualities of the landscape are vulnerable to change from wind and solar energy development. There may be some limited opportunity to accommodate wind turbines/ solar panels without significantly changing landscape character. Great care would be needed in siting and design.
<b>Moderate (M)</b>	Some of the key characteristics and qualities of the landscape are vulnerable to change. Although the landscape may have some ability to absorb wind and solar energy development, it is likely to cause a degree of change in character. Care would be needed in siting and design.
<b>Low - Moderate (L-M)</b>	Fewer of the key characteristics and qualities of the landscape are vulnerable to change. The landscape is likely to be able to accommodate wind and solar energy development with limited change in character. Care is still needed when siting and designing to avoid adversely affecting key characteristics.
<b>Low (L)</b>	Key characteristics and qualities of the landscape are robust in that they can withstand change from the introduction of wind turbines and solar panels. The landscape is likely to be able to accommodate wind and solar energy development without a significant change in character. Care is still needed when siting and designing these developments to ensure best fit with the landscape.

Additionally, the assessment considers the suitability of different turbine heights (to blade tip), based on bandings that reflect those most likely to be put forward by developers (now and in the future). These are set out in Table 55 below.

**Table 55: Wind Turbine Development Sizes Considered in the Landscape Sensitivity Assessment**

Wind Energy Development Banding	Turbine Height (to blade tip)
Band A	18 – 25m
Band B	26 – 60m
Band C	61 – 100m
Band D	101 – 120m
Band E	121 – 150m

The complete assessment methodology and results of a landscape sensitivity assessment is included in the accompanying document 'Landscape Sensitivity Assessment Solar PV and Wind Energy Development - Prepared by LUC – 2021'.

W17 maps show the landscape sensitivity assessment results overlaid on the identified wind Search Areas. The figures rank the area considered for the study in line with the sensitivity levels shown in Table 54 and provide guidance on the potential effects of different scale wind development on the landscape. Higher resolution versions of these maps including those for 500kW, 1.0MW and 2.5MW SAs are contained in the accompanying document 'South Gloucestershire RERAS – Maps'. Table 56 and Table 57 below present the results of the landscape sensitivity assessment for 1.0MW and 2.5MW wind SAs.

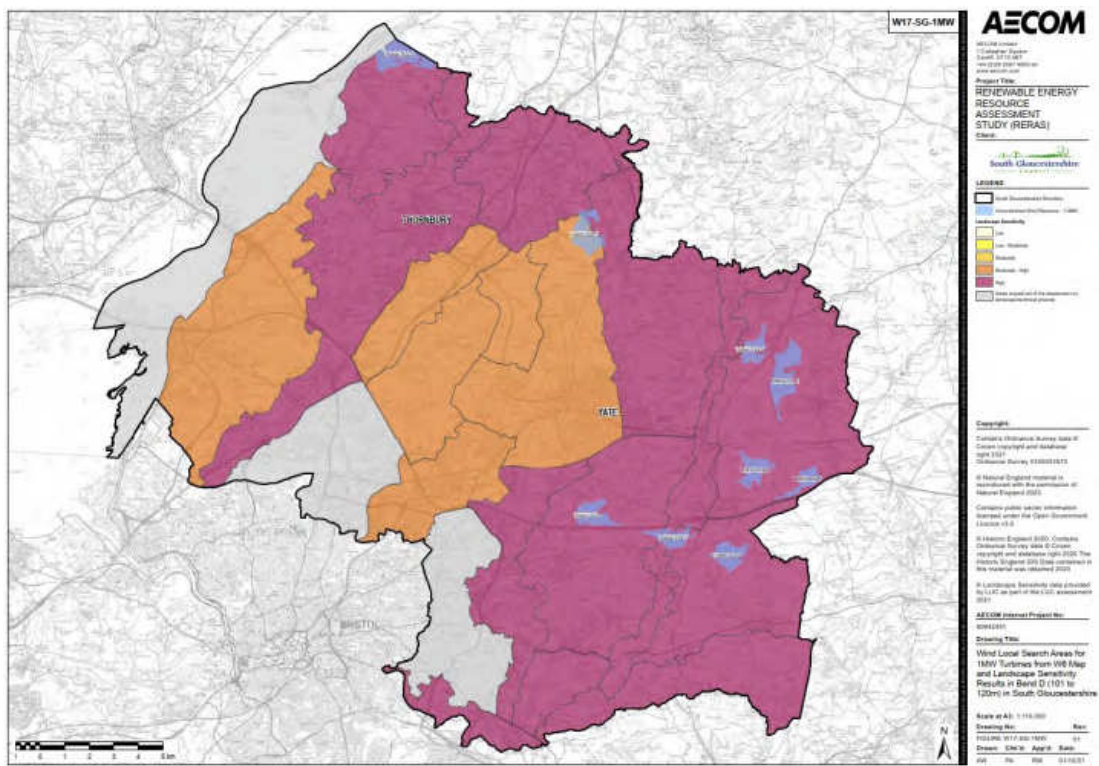

**Figure 98: W17-SG-1MW: Wind Local Search Areas for 1 MW Wind Turbines from W6 map and Landscape Sensitivity Results in Band D (101 to 120) in South Gloucestershire Map**

**Table 56: Individual Identified 1.0MW Wind SA's in South Gloucestershire and Their Landscape Sensitivity Levels**

SA Reference on Maps	Sensitivity Level
1.0MW-1	High
1.0MW-2	High
1.0MW-3	Moderate - High
1.0MW-4	High
1.0MW-5	High
1.0MW-6	High
1.0MW-7	High
1.0MW-8	High
1.0MW-9	High

**Table 57: Individual Identified 2.5MW Wind SA's in South Gloucestershire and Their Landscape Sensitivity Levels**

SA Reference on Maps	Sensitivity Level
2.5MW-1	High
2.5MW-2	High
2.5MW-3	High
2.5MW-4	High
2.5MW-5	High
2.5MW-6	High
2.5MW-7	High
2.5MW-8	Moderate - High



## E.6 Further Constraints to Wind Energy Sites

Further constraints to onshore wind development not considered within this RERAS may include (but are not restricted to):

- Practical access to sites required for development;
- Landowner willingness for development to go ahead;
- National planning policies out of the Council's control;
- Community support; and
- Time to complete planning procedures;

## E.7 Potential Opportunities for Future Development

Wind generation has the potential to be a significant source of renewable energy generation in South Gloucestershire, with the identification of:

- 573 SAs for small (500kW) turbines;
- 9 SAs for medium (1.0MW) turbines; and
- 8 SAs for large (2.5MW) turbines.

The W7 map highlights that there is a considerable overlap of 1.0MW and 2.5MW SAs, with there being significant opportunities for 500kW turbine installations across the South Gloucestershire. Additionally, SAs have been further ranked using the WPD grid connection analysis and the LUC landscape sensitivity assessment. The WPD grid connection analysis can be used to identify the most favourable locations when considering updates to the grid. The LUC landscape sensitivity assessment can guide the Council to the locations that will have the least impact on the landscape.

The W7 map highlights a considerable overlap of 1.0MW and 2.5MW SAs, with there being significant opportunities for 500kW turbine installations across South Gloucestershire.

The only other technology addressed in this study with the potential to produce more renewable electricity was solar PV.

Due to the benefits of wind developments (typically greater CO<sub>2</sub> saving per square metre) as well as the relatively smaller number of sites (and area) for such development as opposed to solar, consideration should be given to protecting such sites solely for wind development as well as against sterilisation from other forms of nearby development.

Moreover, the effects of other constraints such as AONB and Green Belt areas that may impact wind development that would need to be examined as part of the Local Plan process were analysed and included in the study as information to assist the Council in developing its proposed policy approach. The additional maps also cover radar, MoD and aviation safeguarding as well as Conservation Areas (Heritage) to assist developers and councils with any dialogue/that consultation that may be required with these organisations regarding wind turbine installations.

## Appendix F : Wind Energy Primary Resource Constraints Table

The detailed data sources and assumptions can be found in the table below.

Constraint	Buffer	Notes
Special Protection Areas (SPA) and foraging buffers	Extent only	
Special Areas of Conservation (SAC)	Extent only	
RAMSAR sites	Extent only	
National Nature Reserves (NNR)	Extent only	Not present in South Gloucestershire
Sites of Special Scientific Interest (SSSI)	Extent only	
Scheduled Monuments	Extent only	
Listed Buildings, noise buffers have been applied if the building is residential	Extent only (including noise buffer if the building is a dwelling)	<b>Refer to Wind Turbines specifications tables for Topple distances</b>
Registered Historic Parks and Gardens	Extent only	
Registered Battlefields	Extent only	
Ancient Woodlands <sup>240</sup>	15m	The buffer has been applied to avoid root damage
Broadleaved Woodland	15m	The buffer has been applied to avoid root damage <sup>241</sup>
Major transport infrastructure – topple distances buffers have been applied.	Turbines Topple Distance (tip height) +10%	<b>Refer to Wind Turbines specifications tables for Topple distances</b>
Minor transport infrastructure – topple distances buffers have been applied.	Turbines Topple Distance (tip height) +10%	<b>Refer to Wind Turbines specifications tables for Topple distances</b>
Existing buildings	Extent only	
Dwellings (including all buildings in the neighbouring authorities)	Wind Turbines noise buffers have been applied	<b>Refer to Wind Turbines specifications tables for noise buffers</b>
Watercourses – including major, secondary, and minor rivers, canals and lakes; - a 2 metre buffer has been applied to rivers and streams	2m	
MoD Sites	Extent only	

<sup>240</sup> <https://www.gov.uk/guidance/ancient-woodland-and-veteran-trees-protection-surveys-licences>

<sup>241</sup> <https://www.gov.uk/guidance/ancient-woodland-and-veteran-trees-protection-surveys-licences>

<b>Constraint</b>	<b>Buffer</b>	<b>Notes</b>
MOD Low Flying Zones	Extent only	
Operational and consented (but not yet constructed) renewables energy development sites (solar PV and wind)	Extent only	
Active mines/quarries	Extent only	
Local Nature Reserves	Extent only	

## Appendix G : Wind Energy Resource Other Constraints Table

It was agreed that these constraints would need to be examined as part of the preparing the Local Plan and, therefore, have not been constrained further in this assessment.

Constraint	Buffer	Notes
Other woodlands (Other than Broadleaved Woodland and Ancient Woodland)	Extent Only	
Area of Outstanding Natural Beauty (AONB)	Extent Only	
Natural England's Impact Risk Zones for Wind Development (IRZs)	Extent Only	
Unlicensed Aerodromes	Extent Only	
Minerals Safeguarding Areas	Extent Only	
National Air Traffic Control Services (NATS) Radar Safeguarding Areas	Extent Only	
Aviation Safeguarded Zone (MOD and Bristol Airport)	Extent Only	
Flood Zones	Extent Only	
National Trust Inalienable Land	Extent Only	
Green Belt <sup>242</sup>	Extent Only	
MoD Safeguarding Zones	Extent Only	
Historic England Conservation Areas	Extent Only	
Consented (but not yet constructed) solar PV and wind developments where their planning permissions may have lapsed.	Extent Only	

<sup>242</sup> As stated in the NPPF, paragraph 151: 'When located in the Green Belt, elements of many renewable energy projects will comprise inappropriate development. In such cases developers will need to demonstrate very special circumstances if projects are to proceed. Such very special circumstances may include the wider environmental benefits associated with increased production of energy from renewable sources'

## Appendix H : Solar PV Farm

### H.1 Introduction

This section provides details of the assessment of the potential for Solar Photovoltaic (PV) Farms within South Gloucestershire. Information on solar PV can be found in Section 1.8.2.

PV solar cells/ panels generate renewable electricity from the direct conversion of solar irradiation. PV is recognised as one of the key technologies in meeting the UK target of net zero greenhouse gas emissions by 2050. Electricity will be increasingly important in supporting net zero delivery, potentially providing around half of the UK's final energy demand as its use for heat and in transport increases<sup>243</sup>.

In 2019, 28% of renewable installations across the UK were Solar PV in terms of installed capacity. This figure is expected to increase due to a high level of interest in larger stand-alone (ground-mounted) installations<sup>244</sup>.

The Department for Business Energy and Industrial Strategy (BEIS) -formerly the Department for Energy and Climate Change (DECC) defines a “stand-alone” installation as a “solar photovoltaic electricity generating facility that is not wired through a building, or if it is wired through a building, the building does not have the ability to use 10% or more of the electricity generated”.

The FiT scheme was a programme designed to promote the uptake of renewable and low-carbon energy generation technologies under 5MW.

In 2019, 28% of renewable installations across the UK installed capacity were solar PV. This figure is expected to increase due to the falling costs of PV modules leading to increasing viability of subsidy-free ground-mounted solar installations<sup>245</sup>. It should also be noted that larger PV installations are more economically viable. The Contracts for Difference (CfD) scheme is the Government's main mechanism for supporting new low carbon electricity generation projects. The scheme is being updated to support the UK's 2050 net zero target delivery whilst simultaneously minimising consumer costs<sup>246</sup>.

This section provides the approach to a high-level assessment of the potential solar resource for 'stand-alone' PV farms, it is primarily concerned with identifying opportunities for solar PV development of larger than 5MW.

### H.2 Mapping

Maps have been produced to illustrate the results. These maps show the application of the method and identify the primary constraints and opportunities. The flowchart shown in Figure 99 shows the process steps and the output maps at each stage of the mapping process. More detail on the series of steps is provided in this section

<sup>243</sup> [https://assets.publishing.service.gov.uk/government/uploads/system/uploads/attachment\\_data/file/943714/Modelling-2050-Electricity-System-Analysis.pdf](https://assets.publishing.service.gov.uk/government/uploads/system/uploads/attachment_data/file/943714/Modelling-2050-Electricity-System-Analysis.pdf)

<sup>244</sup> <https://www.gov.uk/government/statistics/regional-renewable-statistics>

<sup>245</sup> <https://www.gov.uk/government/statistics/regional-renewable-statistics>

<sup>246</sup> [https://assets.publishing.service.gov.uk/government/uploads/system/uploads/attachment\\_data/file/945301/cfd-cm-scheme-update-2020.pdf](https://assets.publishing.service.gov.uk/government/uploads/system/uploads/attachment_data/file/945301/cfd-cm-scheme-update-2020.pdf)

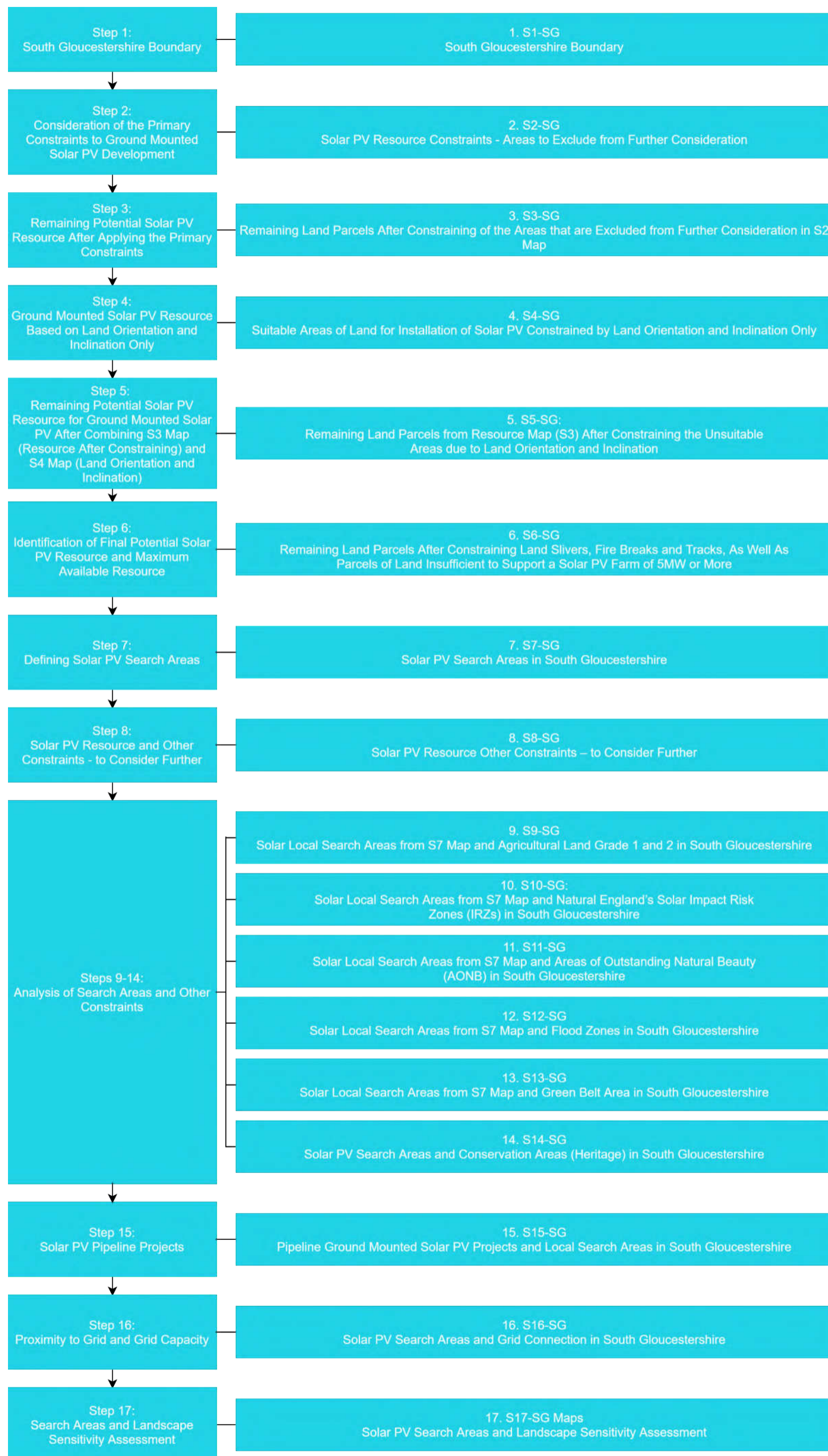

Figure 99: Flowchart Solar PV Farm Mapping Process

Throughout, reference is made to titles and reference numbers to correspond with maps. Screenshots of these maps are included throughout this section. Higher-resolution maps are contained in the accompanying document 'South Gloucestershire RERAS – Maps'.

### Step1: South Gloucestershire Boundary

Map Reference and Title:

#### 1. S1-SG: South Gloucestershire Boundary

This map shows the South Gloucestershire boundary. A higher resolution version of this map is contained in the accompanying document 'South Gloucestershire RERAS – Maps'.

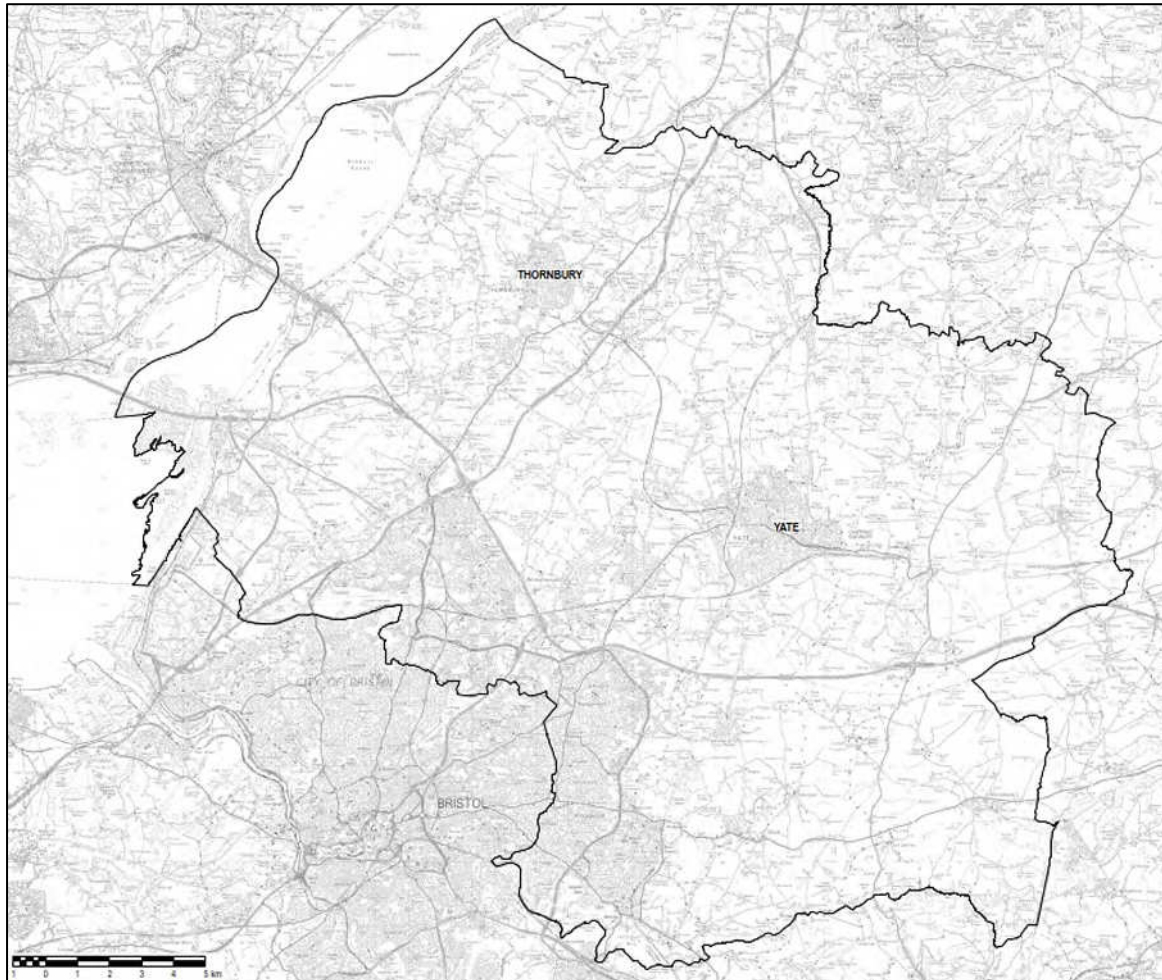

Figure 100: South Gloucestershire Boundary Map

### Step 2: Consideration of the Primary Constraints to Ground Mounted Solar PV Development

Map Reference & Title:

#### 1. S2-SG: Solar PV Resource Constraints - Areas to Exclude from Further Consideration

The purpose of this step was to identify the maximum potential for solar PV farm installation across South Gloucestershire through the identification of constrained areas.

Therefore, consideration was given to the primary constraints associated with restrictions to solar energy development. A comprehensive list of the constraints is given in Appendix I. The solar PV farm S2 constraints map illustrates the primary constraints to the development/ deployment of solar PV farms in South Gloucestershire. For mapping purposes, the constraints, except where specifically stated, relate to the designation's extent only with no additional buffer distances applied.

The primary constraints applied to the maps in Step 2 were as follows:

- Special Protection Areas (SPA);
- Special Areas of Conservation (SAC);
- RAMSAR sites;
- National Nature Reserves (NNR) (none present in South Gloucestershire);
- Sites of Special Scientific Interest (SSSI);
- Scheduled Monuments;
- Listed Buildings; and
- Registered Historic Parks and Gardens.

Many of the 'buffer distances', applied in the maps, are specifically linked to minimising potential impacts upon people or infrastructure through the application of buffers in the mapping exercise. The extent of the buffer areas is informed directly by the nature/extent of the natural/built environment and the characteristics of the generating technology.

This assessment was based on constraints associated with a typical 5MW solar PV array<sup>247</sup>.

The following constraints and their buffer distances (where one has been applied) were considered:

- Ancient Woodlands – a 15-metre buffer has been applied to avoid root damage<sup>248</sup>;
- Broadleaved Woodland, a 15-metre buffer has been applied to avoid root damage<sup>248</sup>;
- Major transport infrastructure;
- Minor transport infrastructure;
- Existing buildings/settlements;
- Watercourses – including major, secondary, and minor rivers, canals, and lakes; - a 2-metre buffer has been applied to rivers and streams;
- Ministry of Defence (MoD) Sites;
- Operational and consented (but not yet constructed) renewables energy development sites (solar PV and wind);
- Active mines/quarries; and
- Local Nature Reserves.

It should be noted that, whilst the above issues have been considered in the selection of the SAs, the SAs remain subject to further investigation based on information provided in this report (e.g. grid connection or landscape sensitivity) or other site-specific characteristics through the Local Plan process as part of developing a strategy for renewable energy development.

A higher resolution version of this map is contained in the accompanying document 'South Gloucestershire RERAS – Maps'.

---

<sup>247</sup> It should be noted that this does not preclude the potential development / deployment of larger or smaller PV farms across the area.

<sup>248</sup> <https://www.gov.uk/guidance/ancient-woodland-and-veteran-trees-protection-surveys-licences>





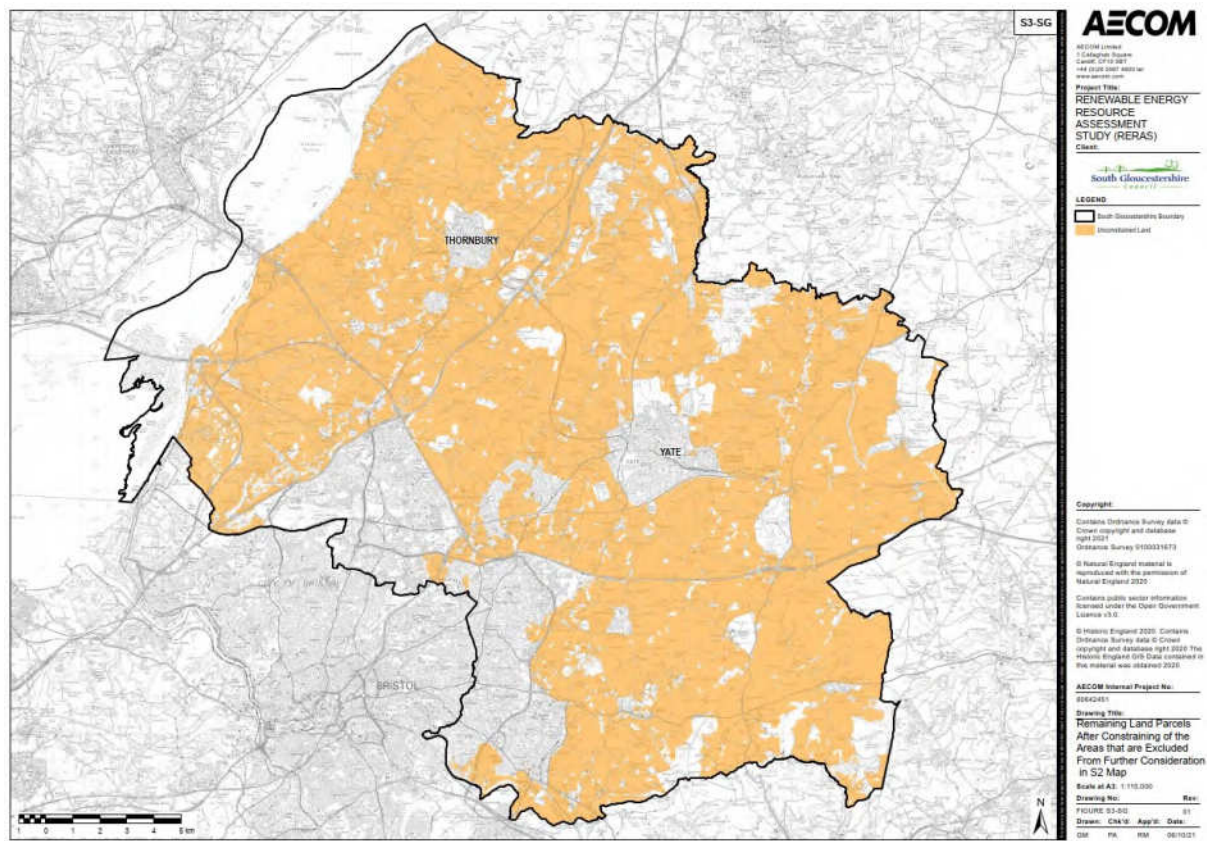

**Figure 102: S3-SG: Remaining Land Parcels After Constraining of the Areas that are Excluded from Further Consideration in S2 Map**

**Table 58: Remaining Land Available for Ground Mounted Solar PV Farms at this Stage of the Assessment and Potential Total Installed Capacity Based on the Available Area**

Map Reference	Remaining Available Land Area (km <sup>2</sup> )	Potential Total Installed Capacity (MW)
S3-SG	342.5	14,272.1 <sup>250</sup>

**Step 4: Ground Mounted Solar PV Resource Based on Land Orientation and Inclination**

Map Reference & Title:

- S4-SG: Suitable Areas of Land for Installation of Solar PV Constrained by Land Orientation and Inclination Only

The areas shown on the S4 map were only constrained by the ability of the technology to utilise the available resource based on land orientations and inclinations.

The performance of a PV panel system is directly related to the inclination, orientation and degree of shading of the panels. For the purposes of identifying the areas suitable for PV farm development, assumptions were made on the suitability of slope gradient and orientation for PV deployment which are summarised in this section. At this stage of the study, a fixed frame PV panel was assumed.

<sup>250</sup> According to the DECC UK Solar PV Strategy Part 1: 'Roadmap to a Brighter Future', the land area required for a 1MW fixed-tilt PV array is approximately 6acres (or 2.4Ha or 0.024km<sup>2</sup>); [https://assets.publishing.service.gov.uk/government/uploads/system/uploads/attachment\\_data/file/249277/UK\\_Solar\\_PV\\_Strategy\\_Part\\_1\\_Roadmap\\_to\\_a\\_Brighter\\_Future\\_08.10.pdf](https://assets.publishing.service.gov.uk/government/uploads/system/uploads/attachment_data/file/249277/UK_Solar_PV_Strategy_Part_1_Roadmap_to_a_Brighter_Future_08.10.pdf)

Using data from Ordnance Survey<sup>251</sup>, AECOM created a data layer for the South Gloucestershire area showing orientation of slope and potential for shading. The following assumptions were applied in this study:

**Table 59: Suitability of Sites for PV Installation at Varying Inclinations**

Suitability of Sites	Inclinations
All suitable:	Inclinations between 0-3 degrees from the horizontal (red coloured areas on S3 map)
Only south-west to south east facing areas are suitable. All other orientations are considered constrained	Inclinations between 3-15 degrees from the horizontal (orange-coloured areas on S4 map).
All constrained	Inclinations >15 degrees from the horizontal

All areas with inclinations of 0-3° from the horizontal were assumed suitable and optimum (red coloured areas on S4 maps). For the areas with inclinations between 3-15° from the horizontal, only south-west to south-east facing areas were assumed to be suitable (amber areas on S4 maps). All other areas were deemed unsuitable for ground-mounted solar PV installation. Table 60 presents the results of this analysis.

A higher resolution version of this map is contained in the accompanying document 'South Gloucestershire RERAS – Maps'.

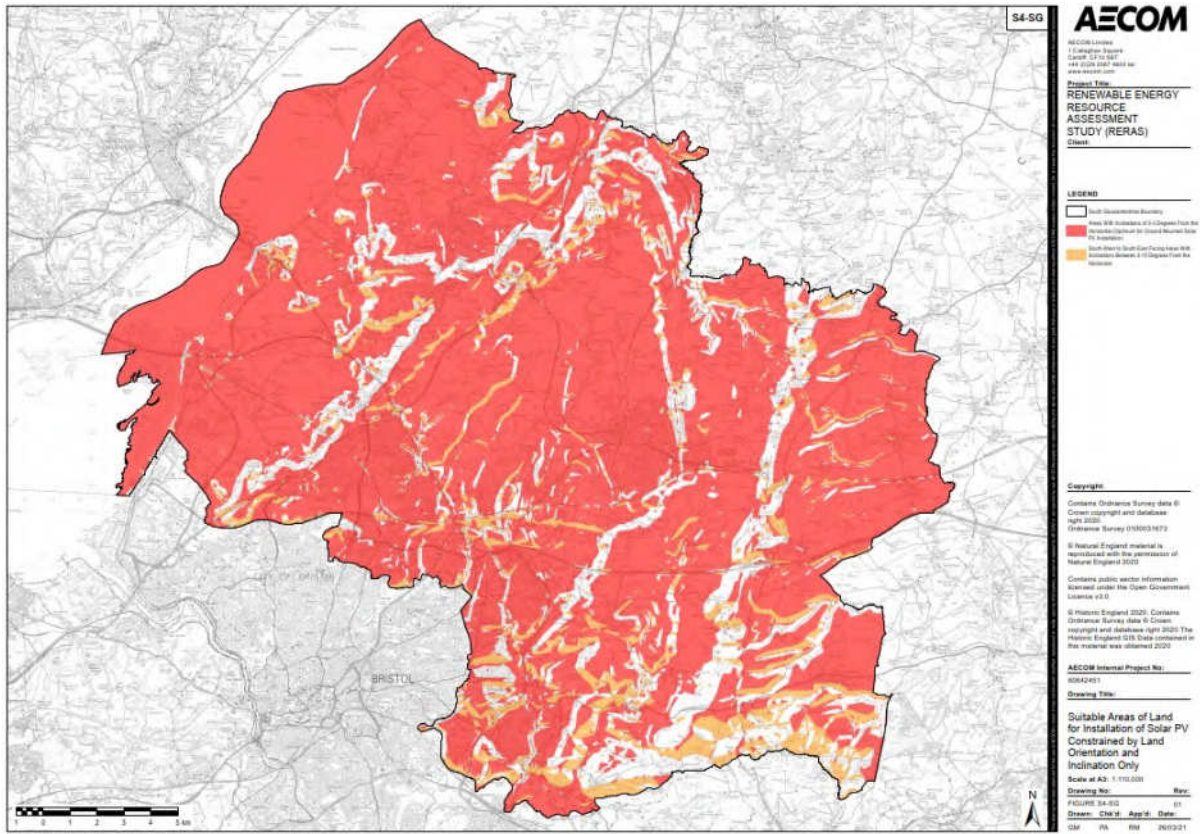

**Figure 103: S4-SG: Suitable Areas of Land for Installation of Solar PV Constrained by Land Orientation and Inclination Only Map**

<sup>251</sup> Ordnance Survey, Terrain 50 dataset  
Prepared for: South Gloucestershire Council

**Table 60: Resource Area for Ground Mounted Solar PV Based on Land Orientation and Inclination Only**

Map Reference	Total Area of South Gloucestershire (km <sup>2</sup> )	Resource Area for PV (km <sup>2</sup> )	Percentage of Total Area
S4-SG	536.40	453.82	84.6%

**Step 5: Remaining Available Land for Ground Mounted Solar PV After Combining S3 Map (Resource After Constraining) and S4 Map (Land Orientation and Inclination)**

Map Reference & Title:

1. S5-SG: Remaining Land Parcels from Resource Map (S3) After Constraining the Unsuitable Areas due to Land Orientation and Inclination

At this stage of the assessment, unsuitable areas due to inappropriate land orientation and inclination were removed from S3 maps and presented. Table 61 below shows the remaining potential solar PV resource<sup>252</sup> at this stage and its potential total installed capacity.

A higher resolution version of this map is contained in the accompanying document ‘South Gloucestershire RERAS – Maps’.

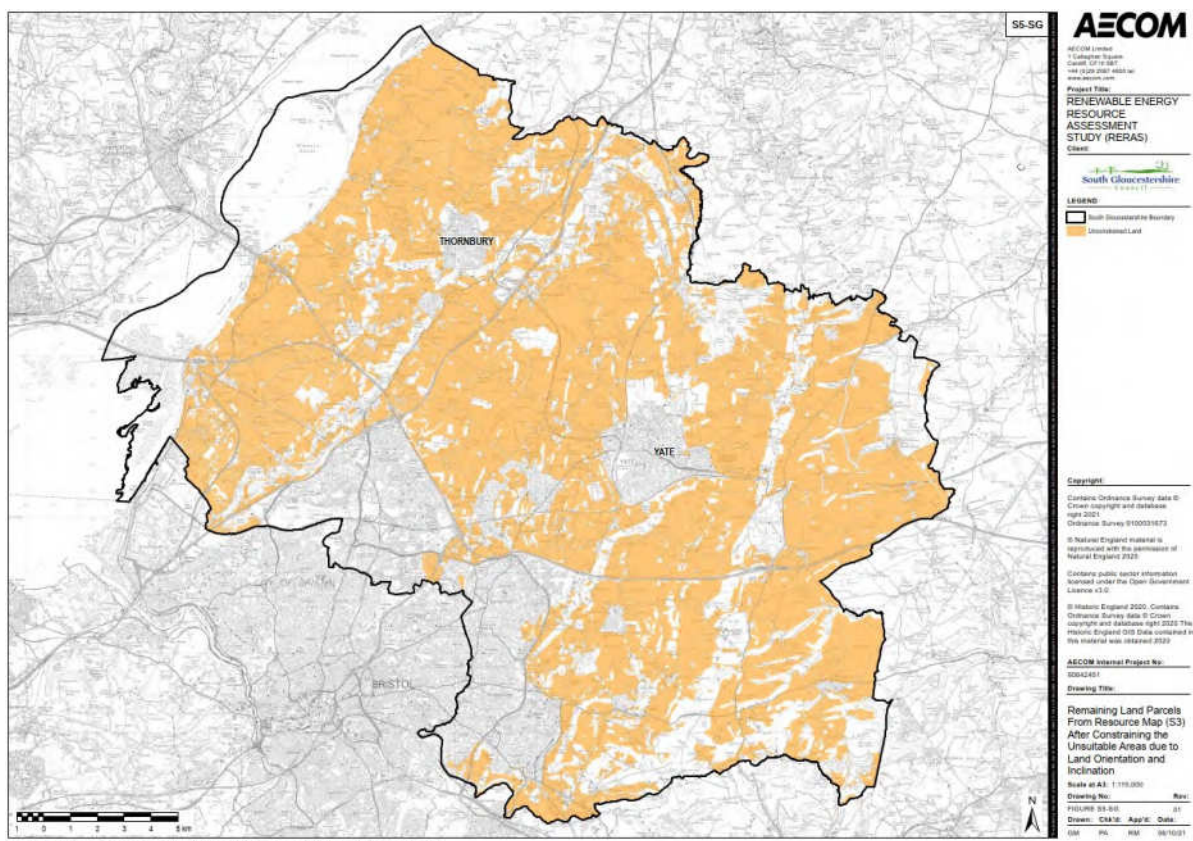

**Figure 104: S5-SG: Remaining Land Parcels from Resource Map (S3) After Constraining the Unsuitable Areas due to Land Orientation and Inclination Map**

**Table 61: Remaining Land Available for Ground Mounted Solar PV Farms at this Stage of the and its Potential Total Installed Capacity**

Map Reference	Remaining Available Land Area (km <sup>2</sup> )	Potential Total Installed Capacity (MW)
S5-SG	290.93	12,122.1 <sup>253</sup>

<sup>252</sup>Labelled as “Unconstrained Land” on S5 map

<sup>253</sup> According to the DECC UK Solar PV Strategy Part 1: ‘Roadmap to a Brighter Future’, the land area required for a 1MW fixed-tilt PV array is approximately 6acres (or 2.4Ha or 0.024km<sup>2</sup>);

[https://assets.publishing.service.gov.uk/government/uploads/system/uploads/attachment\\_data/file/249277/UK\\_Solar\\_PV\\_Strategy\\_Part\\_1\\_Roadmap\\_to\\_a\\_Brighter\\_Future\\_08.10.pdf](https://assets.publishing.service.gov.uk/government/uploads/system/uploads/attachment_data/file/249277/UK_Solar_PV_Strategy_Part_1_Roadmap_to_a_Brighter_Future_08.10.pdf)

## Step 6: Identification of Final Potential Solar PV Resource and Maximum Available Resource

Map Reference & Title:

1. S6-SG: Remaining Land Parcels After Constraining Land Slivers, Fire Breaks and Tracks, As Well As Parcels of Land Insufficient to Support a Solar PV Farm of 5MW or More

At this stage of the assessment, land slivers, fire breaks and tracks, as well as parcels of land insufficient to support a solar PV farm of 5MW or more, were removed from Step 5 maps. It should be noted that schemes smaller than 5MW may be brought forward and these would need to be considered on their own merits.

Following the application of the primary constraints, the remaining potential solar PV resource<sup>254</sup> informs the calculation of the maximum potential generation capacity. This number then informs identification of the theoretical maximum renewable energy generation in South Gloucestershire, see Section 15.

A higher resolution version of this map is contained in the accompanying document ‘South Gloucestershire RERAS – Maps’.

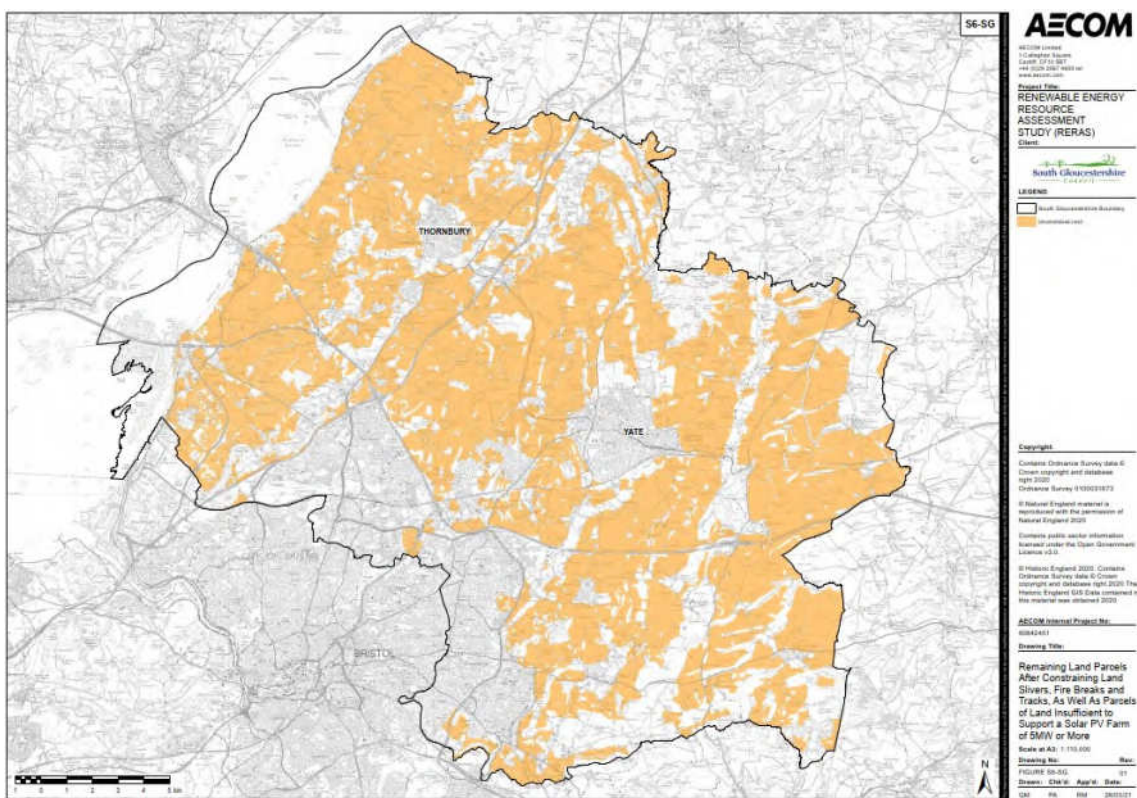

**Figure 105: S6-SG: Remaining Land Parcels After Constraining Land Slivers, Fire Breaks and Tracks, As Well As Parcels of Land Insufficient to Support a Solar PV Farm of 5MW or More Map**

The additional future potential electricity generation is outlined in Table 62.

**Table 62: Remaining Land Available for Ground Mounted Solar PV Farms at this Stage and its Potential Total Installed Capacity**

Map Reference	Remaining Available Land Area (km <sup>2</sup> )	Potential Total Installed Capacity (MW)	Potential Energy Generated (GWh)
S6-SG	268.42	11,184.2	9,797

<sup>254</sup>Labelled as “Unconstrained Land” on S6 map  
Prepared for: South Gloucestershire Council

## Step 7: Defining Solar PV Search Areas

Map Reference & Title:

### 1. S7-SG: Solar PV Search Areas in South Gloucestershire

This RERAS is primarily concerned with identifying solar PV development opportunities larger than 5MW. AECOM created a GIS grid layer where each square area is equivalent to a 5MW solar farm. As the S6 map illustrates, there is a significant remaining solar PV resources<sup>255</sup> suitable for ground-mounted PV installations in South Gloucestershire. 'Stand-alone' PV farms >5MW must be appropriately sited; however, with a large number of potential sites, to assist with further analysis in relation to the electricity grid and landscape assessment, the S7 map illustrates the grid overlaid on the remaining areas. Therefore, each square is defined and referenced as a solar PV Search Area (SA) in South Gloucestershire.

#### Policy Recommendation

##### Policy Reference: SF-PR-1 (Refer to Table 40 in Section 17)

It is recommended that the SAs identified through the RERAS are further refined through the Local Plan process, taking account of other considerations and constraints. As part of this a strategy approach which takes account of clustering and the potential need to manage cumulative impact should be considered.

#### Policy Recommendation

##### Policy Reference: SF-PR-2 (Refer to Table 40 in Section 17)

It is recommended that proposals for solar PV farms within the areas identified for that use through the Local Plan benefit from a presumption in favour of solar development.

#### Policy Recommendation

##### Policy Reference: SF-PR-3 (Refer to Table 40 in Section 17)

It is recommended that proposals for solar development outside of areas identified as suitable for that use through the Local Plan should be considered positively, providing it can demonstrate that proposals are compliant with relevant policy and site-specific issues and constraints can be mitigated to the satisfaction of the Council.

As explained above, areas of constraint have been applied through mapping to begin to identify potentially suitable locations for the development of solar PV farms, and these are labelled as solar PV farm Search Areas. However, these search areas will need to be refined further through the Local Plan process, taking into account other considerations and constraints, as part of developing a strategy for renewable energy development.

A higher resolution version of this map is contained in the accompanying document 'South Gloucestershire RERAS – Maps'.

<sup>255</sup>Labelled as "Unconstrained Land" on S7 map  
Prepared for: South Gloucestershire Council

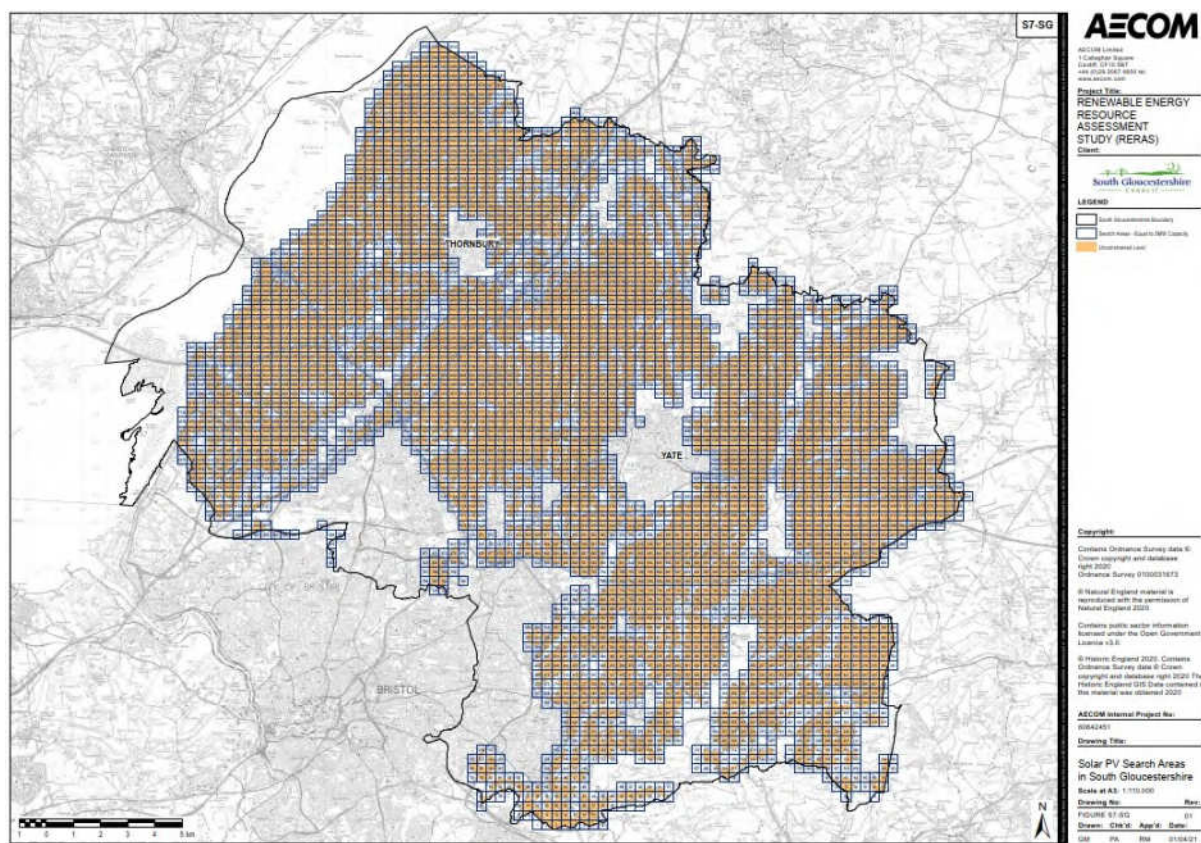

**Figure 106: S7-SG: Solar PV Search Areas in South Gloucestershire Map**

A total of 268.42km<sup>2</sup> of land was identified as being potentially suitable for the installation of a solar PV farm. This area comprises a large part of rural South Gloucestershire, as can be seen in Figure 106.

It was assumed the land area required for a 5MW fixed-tilt PV array is approximately 30acres (or 12Ha or 0.12km<sup>2</sup>)<sup>256</sup> and that a solar farm will generate energy at peak for 11% of the time (964 hours) over the course of a year<sup>257</sup>.

### Step 8: Solar PV Resource Other Constraints – to Consider Further

Map Reference & Title:

1. S8-SG: Solar PV Resource Other Constraints – to Consider Further

This section of the study analyses the effects of other constraints that may impact ground-mounted solar PV development within the SAs. The constraints highlighted in this section of the study would need to be examined and considered as part of the Local Plan process and, therefore, the identified SAs in mapping Step 6 have not been constrained further during this stage.

S8 maps illustrate the following additional constraints (see Appendix J).

- Other woodlands (Other than Broadleaved Woodland and Ancient Woodland);
- Area of Outstanding Natural Beauty (AONB);
- Natural England's Impact Risk Zones for Solar Development (IRZs);
- Minerals Safeguarding Areas;
- Flood Zones;
- National Trust Inalienable Land;

<sup>256</sup> According to the DECC UK Solar PV Strategy Part 1: 'Roadmap to a Brighter Future', the land area required for a 1MW fixed-tilt PV array is approximately 6acres (or 2.4Ha or 0.024km<sup>2</sup>). See *above link*

<sup>257</sup> Average of the five previous years' regional standard load factors published by BEIS.

- Green Belt<sup>258</sup>;
- Agricultural Land Classification (ALC);
- Historic England Conservation Areas; and
- Consented (but not yet constructed) solar PV and wind developments which their planning permissions may have been lapsed.

A higher resolution version of this map is contained in the accompanying document 'South Gloucestershire RERAS – Maps'.

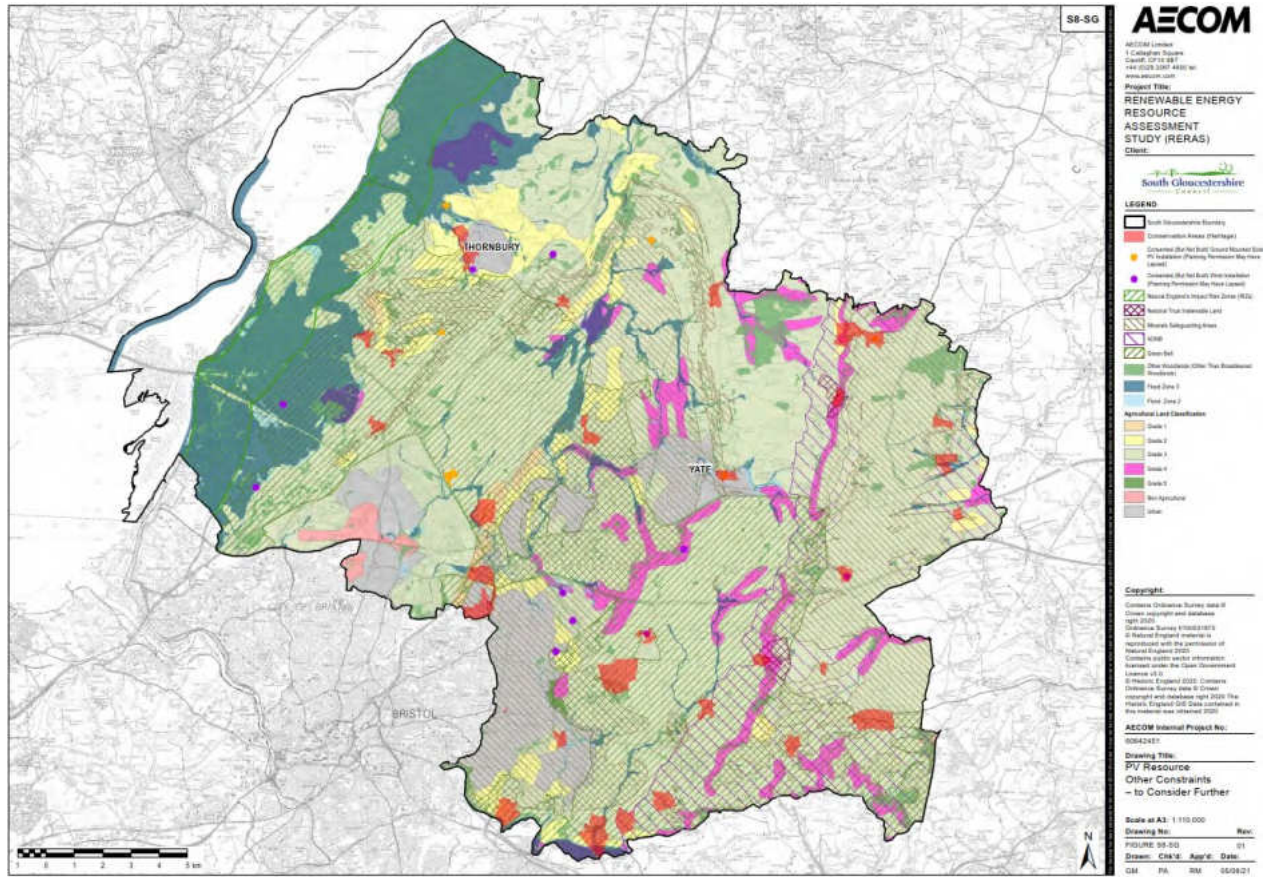

**Figure 107: S8-SG: Solar PV Resource Other Constraints – to Consider Further Map**

**Remaining Area of SAs after Applying Selected Additional Constraints**

Map References & Titles:

1. S9-SG: Solar Local Search Areas from S7 Map and Agricultural Land Grade 1 and 2 in South Gloucestershire
2. S10-SG: Solar Local Search Areas from S7 Map and Natural England’s Solar Impact Risk Zones (IRZs) in South Gloucestershire
3. S11-SG: Solar Local Search Areas from S7 Map and Areas of Outstanding Natural Beauty (AONB) in South Gloucestershire
4. S12-SG: Solar Local Search Areas from S7 Map and Flood Zones in South Gloucestershire
5. S13-SG: Solar Local Search Areas from S7 Map and Green Belt Area in South Gloucestershire
6. S14-SG: Solar PV Search Areas and Conservation Areas (Heritage) in South Gloucestershire

<sup>258</sup> As stated in the NPPF, paragraph 151: ‘When located in the Green Belt, elements of many renewable energy projects will comprise inappropriate development. In such cases developers will need to demonstrate very special circumstances if projects are to proceed. Such very special circumstances may include the wider environmental benefits associated with increased production of energy from renewable sources’



Maps are produced to show the impacts of applying the following overlays to the solar PV SAs map, map S7. Table 63 provides further information regarding each map's remaining area and potential capacity if the overlapping areas covering these other constraints and SAs were removed.

- Agricultural Land Grade 1 and 2;
- Natural England's Impact Risk Zones for Solar Development (IRZs);
- Area of Outstanding Natural Beauty (AONB);
- Flood Zones; and
- Green Belt;

Higher resolution versions of these maps are contained in the accompanying document 'South Gloucestershire RERAS – Maps'.

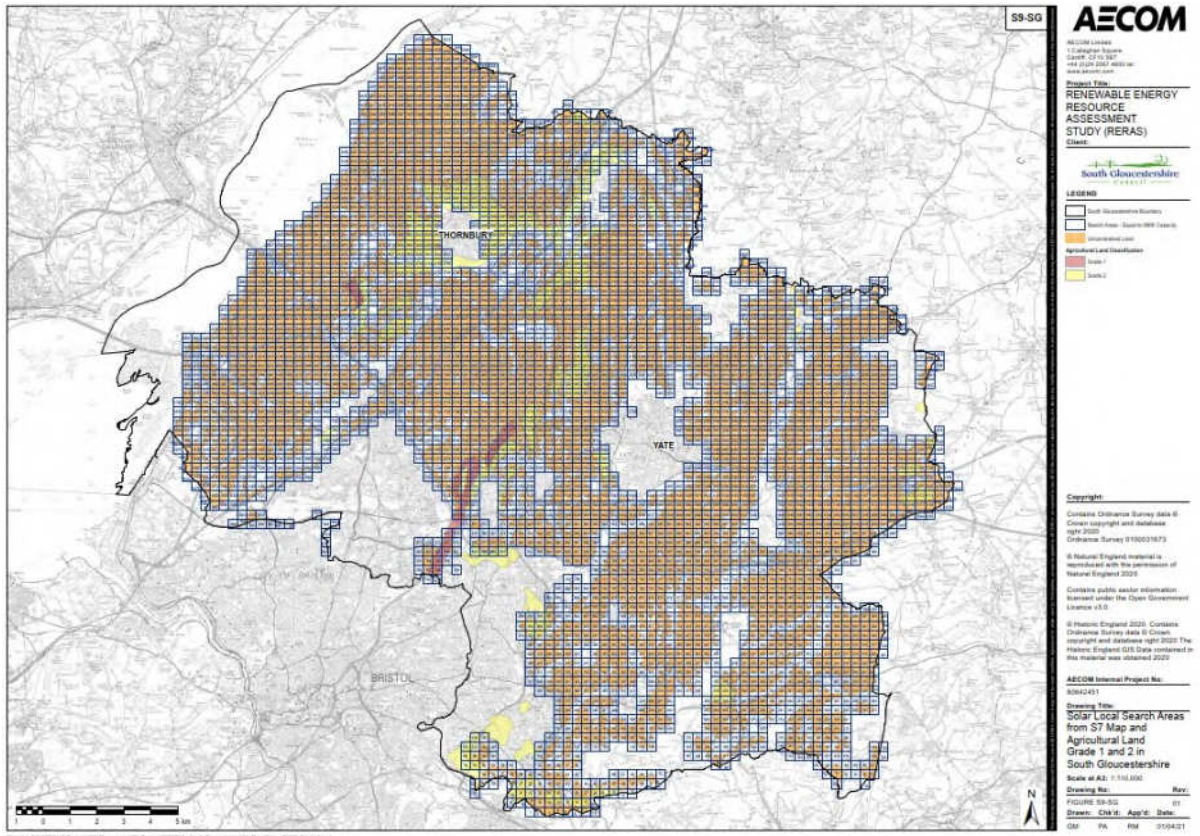

Figure 108: S9-SG: Solar Local Search Areas from S7 Map and Agricultural Land Grade 1 and 2 in South Gloucestershire Map

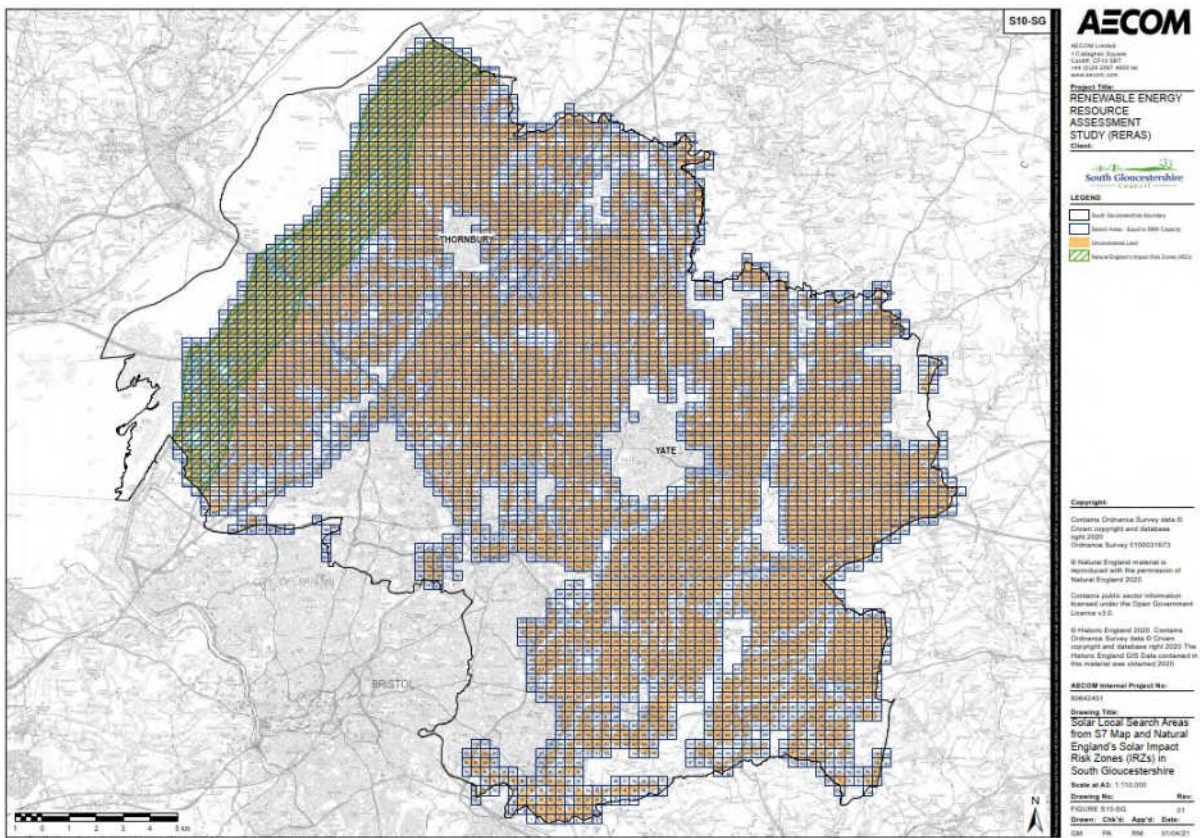

Figure 109: S10-SG: Solar Local Search Areas from S7 Map and Natural England's Solar Impact Risk Zones (IRZs) in South Gloucestershire Map

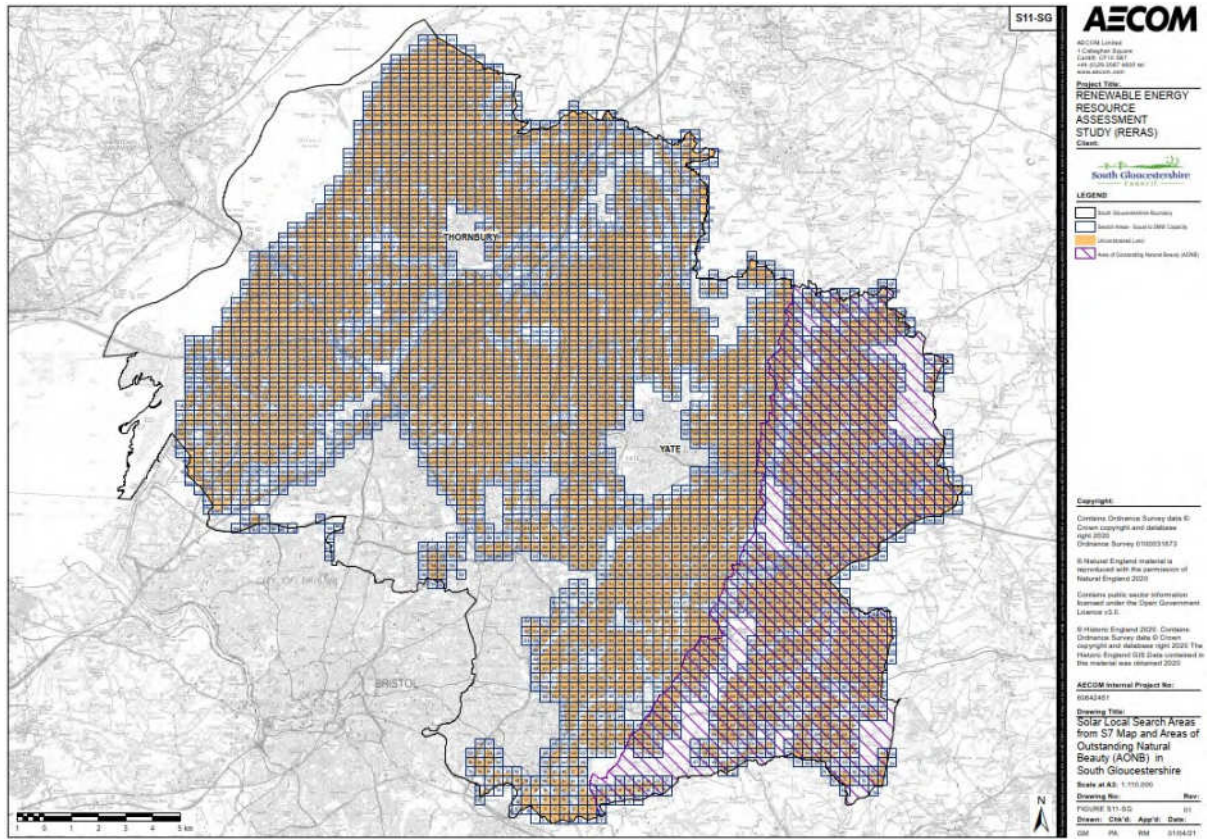

Figure 110: S11-SG: Solar Local Search Areas from S7 Map and Areas of Outstanding Natural Beauty (AONB) in South Gloucestershire Map

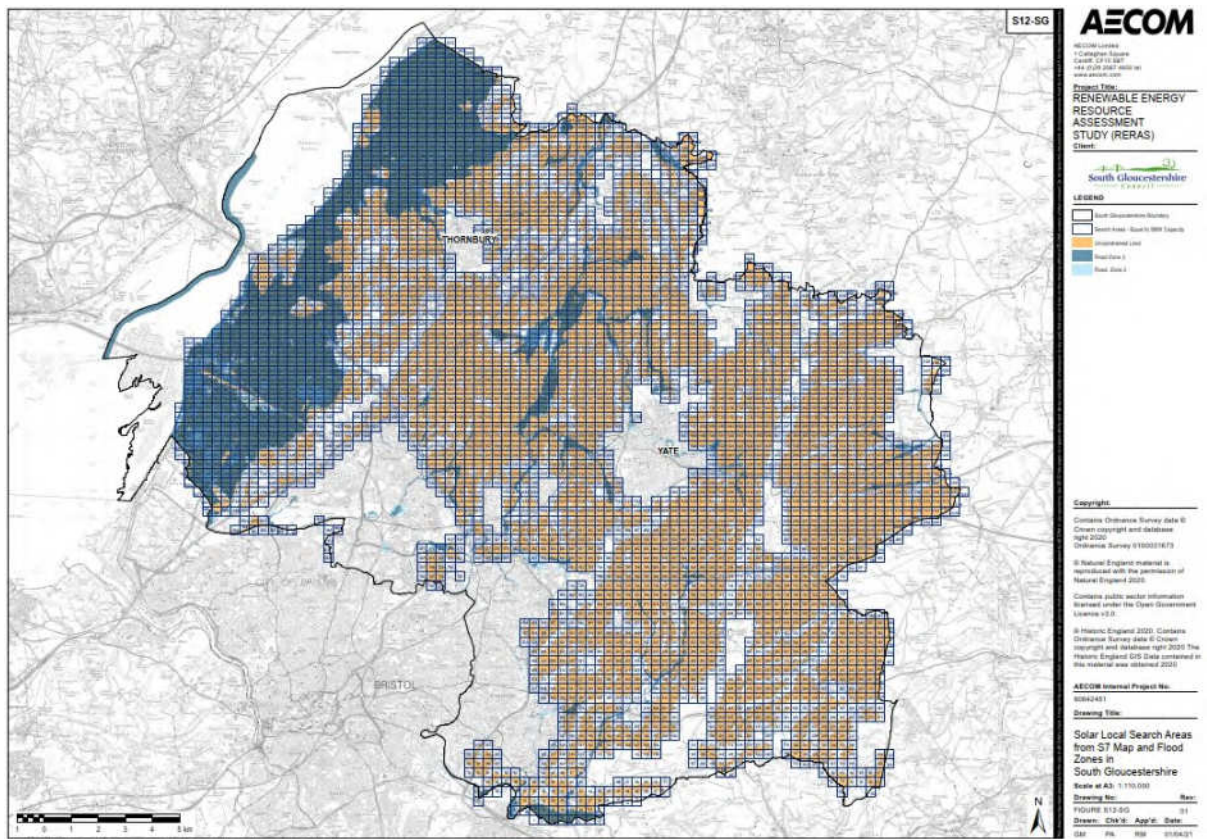

Figure 111: S12-SG: Solar Local Search Areas from S7 Map and Flood Zones in South Gloucestershire Map

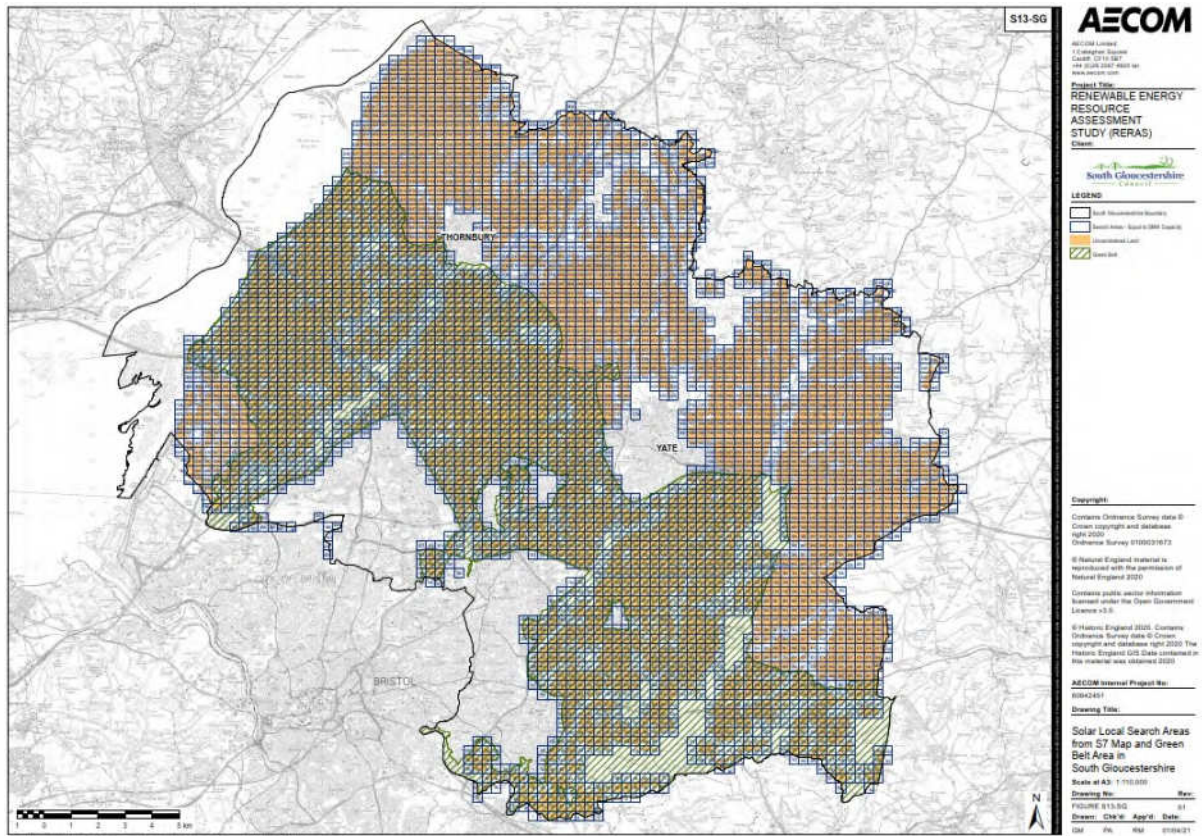

Figure 112: S13-SG: Solar Local Search Areas from S7 Map and Green Belt Area in South Gloucestershire Map

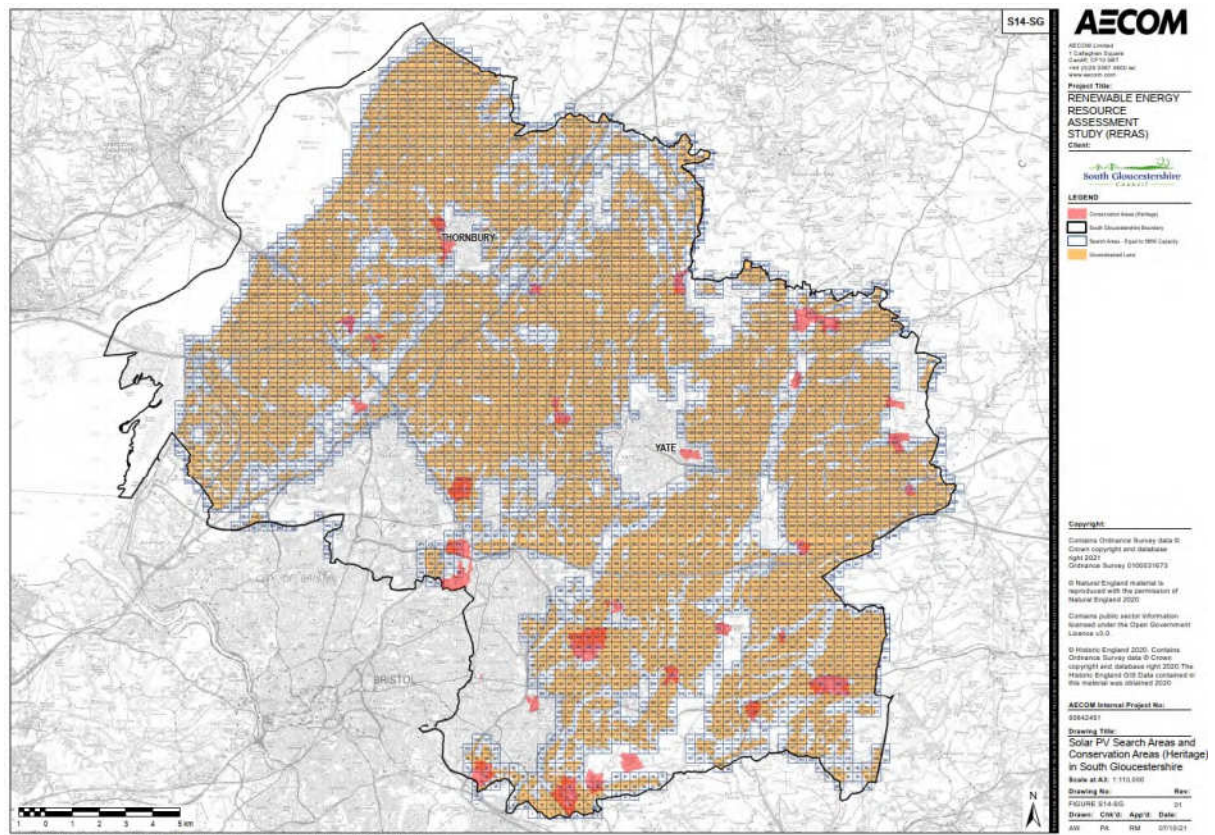

Figure 113: S14-SG: Solar PV Search Areas and Conservation Areas (Heritage) in South Gloucestershire Map

**Table 63: Remaining Area of SAs After Applying Selected Additional Constraints for Illustrative Purposes Only**

Map Reference	Other Constraint Shown on the Map	Area of the Final Solar SAs Identified in Step 6 (km <sup>2</sup> )	Potential Installed Capacity of the Final Solar SAs (MW)	Remaining SAs if Area of the Other Constraint Is Removed (km <sup>2</sup> )	Remaining Potential Installed Capacity of the SAs if Area of the Other Constraint Is Removed (MW)
S9-SG	Agricultural Land Grade 1 and 2	268.42	11,184.2	249.07	10,377.9
S10-SG	Natural England's IRZs for Solar	268.42	11,184.2	237.6	9,900.0
S11-SG	AONB	268.42	11,184.2	203.09	8,462.1
S12-SG	Flood Zones	268.42	11,184.2	209.34	8,722.5
S13-SG	Green Belt	268.42	11,184.2	131.17	5,465.4

In England, the planning authorities are obliged to designate as conservation areas any parts of their own area that are of special architectural or historic interest, the character and appearance of which it is desirable to preserve or enhance. Under the National Planning Policy Framework (NPPF) conservation areas are designated heritage assets and their conservation is to be given weight in planning permission decisions<sup>259</sup>. Therefore, the S14 map is prepared that shows the location of the Conservation Areas in relation to the SAs to assist the Council and developers when considering renewable energy proposals.

### H.3 Pipeline Projects

Map Reference & Title:

1. S15-SG: Pipeline Ground Mounted Solar PV Projects and Local Search Areas in South Gloucestershire

In this section of the report, Regen's Distribution Future Energy Scenarios (DFES) analysis is utilised to identify pipeline solar PV projects in South Gloucestershire. Project readiness of the identified Search Areas in relation to the current grid capacity and potential costs of grid upgrades are considered in H.4. The methodology used for pipeline analysis is in line with the method outlined in E.3.

Table 64 includes details of the identified pipeline solar PV projects in South Gloucestershire. S14 map illustrates the location of these sites in relation to the identified SAs. It should be noted that any site with extant planning permission is shown and constrained on S2 maps as consented (but not yet constructed) developments.

<sup>259</sup> <https://historicengland.org.uk/advice/hpg/has/conservation-areas/>  
Prepared for: South Gloucestershire Council

**Table 64: Pipeline Solar PV Projects in South Gloucestershire.**

Site / Developer Name	Location (X-coordinate)	Location (Y-coordinate)	Capacity (MW)	DEFES Pipeline Connection Information (If Available)							
				Steady Progression		System Transformation		Consumer Transformation		Leading the Way	
				Connection Date	Capacity (MW)	Connection Date	Capacity (MW)	Connection Date	Capacity (MW)	Connection Date	Capacity (MW)
Aura Power Solar UK Ltd	366792.4	185738.9	50.0			2028	50	2028	50	2025	50
Rag Lane Solar Ltd	369876	188154	49.0			2025	49	2024	49	2022	49
Perinnpitt Road Solar Limited	364694	183333	49.0 <sup>260</sup>								
The Wave	360621.6	183605.3	3.16								
S R Construction	364006.5	188494.0	0.09								
ECT Slimbridge Estate Solar	366792.4	185738.9	42.1								
Green Larks Green Solar Farm	367,014	186,672	49.0							2026	49

A higher resolution version of this map is contained in the accompanying document 'South Gloucestershire RERAS – Maps'.

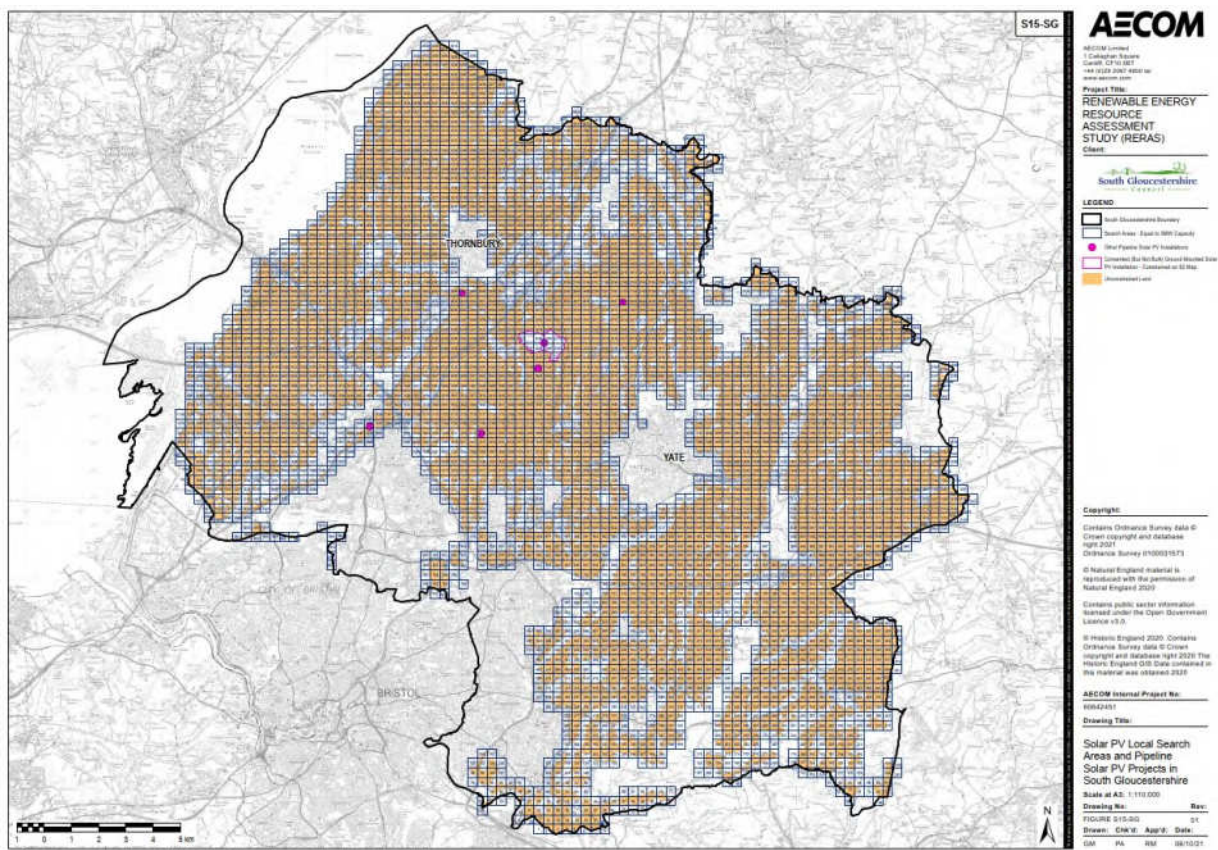

Figure 114: S15-SG: Pipeline Ground Mounted Solar PV Projects and Local Search Areas in South Gloucestershire Map

## H.4 Proximity to Grid and Grid Capacity

Map Reference & Title:

### 1. S16-SG: Solar PV Search Areas and Grid Connection in South Gloucestershire

Whilst private wire schemes are an option, and some already exist in the UK, solar farms usually have a connection to the grid to export electricity, albeit with increasing curtailments.

Consideration of a viable connection point is an important factor when considering sites for new solar energy development. The cost of a grid connection depends on the distance to the nearest connection point the works needed to make that connection (there can be a number of complexities such as land ownership issues, whether the dig is hard or soft, etc) and the availability of capacity in the distribution network to take the additional power output. For this study, grid connection is assumed to be a discussion matter for national-level decision-makers and has not been used to constrain solar PV energy generation potential. In addition, as renewable deployment is a national priority, it is assumed that the grid requirement will be met to allow for sufficient additional capacity.

However, a high-level analysis exercise has been undertaken in consultation with the Distribution Network Operator, Western Power Distribution (WPD), to rank the solar PV SAs and assess their project readiness based on the network capacity maps and connection points at the time of writing (August 2021). The solar SAs have been divided into 50MW parcels in to allow WPD to perform their assessment of the sites. Additionally, there are multiple large scale (circa 50MW) proposals in different planning stages in South Gloucestershire. This could be due to the fact that electricity generators that generate lower than 50MWe are exempt from the requirement for an electricity licence<sup>261</sup>.

<sup>261</sup> Class A: Small generators – Generates lower than 50 megawatts with a declared net capacity of up to 100 megawatts. <https://www.legislation.gov.uk/ukxi/2001/3270/schedule/2/made>  
Prepared for: South Gloucestershire Council

The Search Areas are ranked from low priority (coloured red in the maps) to high priority (coloured blue in the maps), with high priority being most favourable for a new grid connection, as shown in Figure 115 and Figure 116.

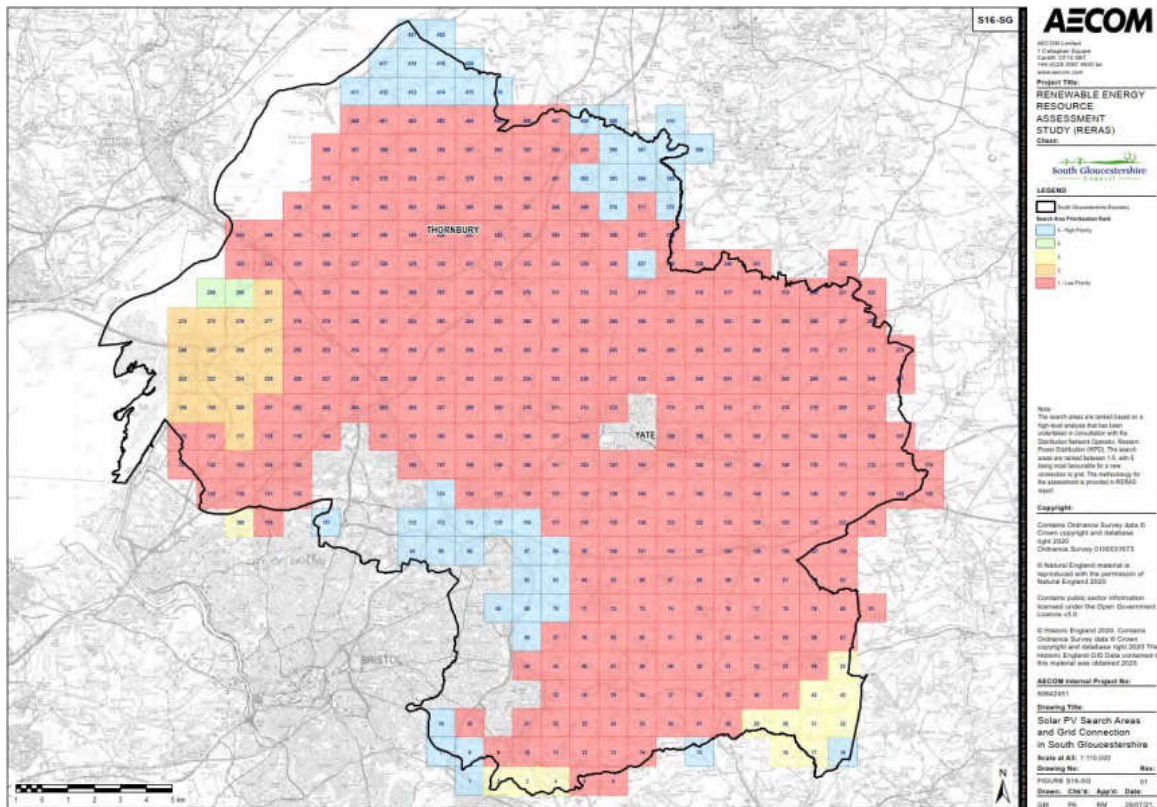

**Figure 115: SAs Proximity to Grid and Grid Capacity Ranking Key (Refer to map S16 in the Accompanying Document 'South Gloucestershire RERAS – Maps')**

This ranking has only been taken as a single snapshot based on the latest information. It does not account for any future reinforcement that may be triggered by other new connections or condition-based replacement. Increases or decreases in future demand may also affect capacity and have not been considered within this study. Sites over 1MW may be required to go through the Statement of Works process to confirm acceptance of the connection on the transmission network.

Network access may be accelerated or achieved with reduced costs by progressing an alternative connection, which allows export to be limited at times of high export from other users. A higher resolution version of this map is contained in the accompanying document 'South Gloucestershire RERAS – Maps'.





**Figure 116: S16-SG: 50MW Solar PV Search Areas and Grid Connection in South Gloucestershire Map**

### H.5 Landscape Sensitivity Assessment

Map References & Titles:

1. S17-SG-Band A: Solar Local Search Areas from S6 Map and Landscape Sensitivity Results in Band A ( $\leq 5$ ha) in South Gloucestershire Map
2. S17-SG-Band B: Solar Local Search Areas from S6 Map and Landscape Sensitivity Results in Band B (6ha to 10ha) in South Gloucestershire Map
3. S17-SG-Band C: Solar Local Search Areas from S6 Map and Landscape Sensitivity Results in Band C (11ha to 15ha) in South Gloucestershire Map
4. S17-SG-Band D: Solar Local Search Areas from S6 Map and Landscape Sensitivity Results in Band D (16ha to 30ha) in South Gloucestershire Map
5. S17-SG-Band E: Solar Local Search Areas from S6 Map and Landscape Sensitivity Results in Band E (31ha to 60ha) in South Gloucestershire Map

An additional parameter that can be considered in ranking the Search Areas is Landscape Character Areas and the sensitivity of these landscapes to new solar PV farm developments. A flowchart presenting the steps taken in completing mapping the results of a landscape sensitivity for solar PV farms is shown in Figure 117.

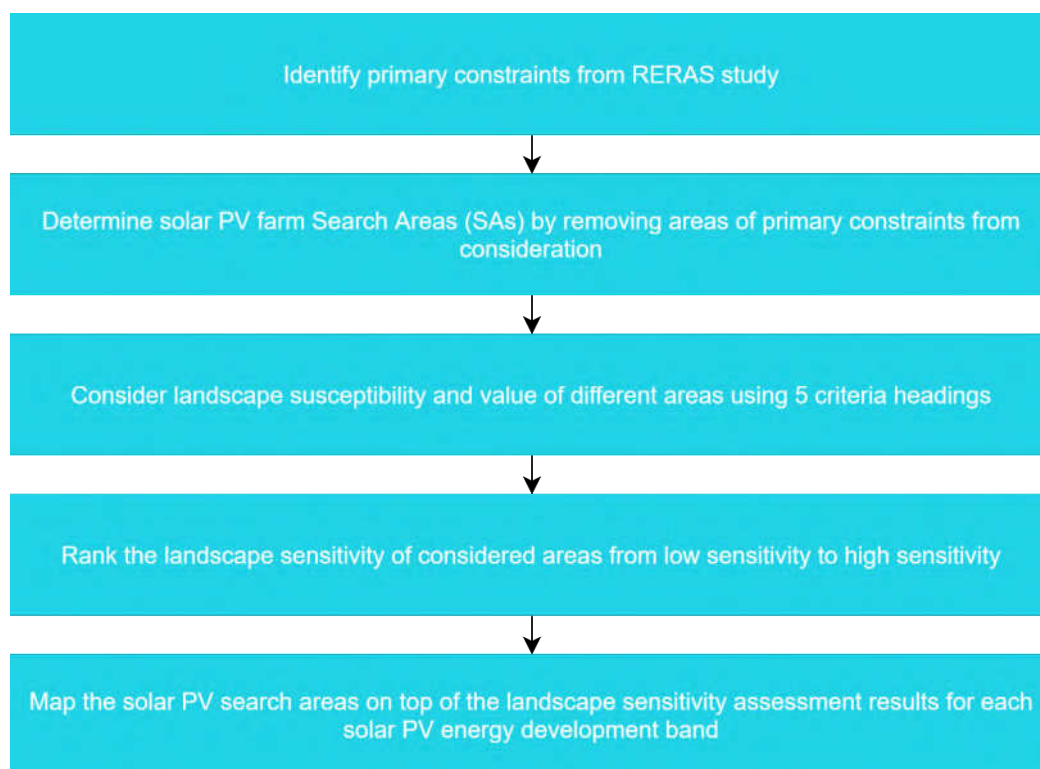

**Figure 117 Steps Taken in Landscape Sensitivity Study for Solar PV Farm Search Areas**

LUC has conducted a landscape sensitivity assessment for solar energy development as part of this RERAS. Results of the assessment provide an initial indication of the relative landscape sensitivity of different areas within South Gloucestershire to accommodate solar PV energy developments. The findings of the study, combined with the identified Search Areas, are presented in this section of the report. The landscape sensitivity assessment considers the landscape susceptibility<sup>262</sup> and landscape value<sup>263</sup> using 5 criteria headings:

- Landform and scale (including sense of openness / enclosure);
- Landcover (including field and settlement patterns);
- Historic landscape character;
- Visual character (including skylines); and
- Perceptual and scenic qualities.

Once the above criteria were assessed individually, the results were identified with an overall sensitivity level, as shown in Table 65.

<sup>262</sup> How vulnerable the landscape is to change from the type being assessed, in this case solar PV and wind energy developments

<sup>263</sup> Consensus about importance, which can be recognised through designation as well as through descriptions within the 2014 Landscape Character Assessment  
Prepared for: South Gloucestershire Council

**Table 65: The Five-Point Scale Landscape Sensitivity Scale**

Sensitivity Level	Definition
<b>High (H)</b>	Key characteristics and qualities of the landscape are highly vulnerable to change from wind and solar energy development. Such development is likely to result in a significant change in character.
<b>Moderate - High (M-H)</b>	Key characteristics and qualities of the landscape are vulnerable to change from wind and solar energy development. There may be some limited opportunity to accommodate wind turbines/ solar panels without significantly changing landscape character. Great care would be needed in siting and design.
<b>Moderate (M)</b>	Some of the key characteristics and qualities of the landscape are vulnerable to change. Although the landscape may have some ability to absorb wind and solar energy development, it is likely to cause a degree of change in character. Care would be needed in siting and design.
<b>Low - Moderate (L-M)</b>	Fewer of the key characteristics and qualities of the landscape are vulnerable to change. The landscape is likely to be able to accommodate wind and solar energy development with limited change in character. Care is still needed when siting and designing to avoid adversely affecting key characteristics.
<b>Low (L)</b>	Key characteristics and qualities of the landscape are robust in that they can withstand change from the introduction of wind turbines and solar panels. The landscape is likely to be able to accommodate wind and solar energy development without a significant change in character. Care is still needed when siting and designing these developments to ensure best fit with the landscape.

Additionally, the assessment judges the suitability of different scales of solar PV developments based on bandings that reflect those that are most likely to be put forward by developers. The sizes<sup>264</sup> used for the assessment are set out in Table 66<sup>265</sup>.

**Table 66: Solar PV Farm Development Sizes Considered in the Landscape Sensitivity Assessment**

Solar PV Development Banding	Area
Band A	≤5ha
Band B	6ha – 10ha
Band C	11ha – 15ha
Band D	16ha – 30ha
Band E	31ha – 60ha

The complete assessment methodology and results of a landscape sensitivity assessment is included in the accompanying document 'Landscape Sensitivity Assessment Solar PV and Wind Energy Development - Prepared by LUC – 2021'.

S17 maps show the landscape sensitivity assessment results overlaid on the identified solar PV Search Areas. The figures rank the areas considered for the landscape sensitivity study in line with the sensitivity levels shown in Table 66 and provide guidance on the potential effects of different scale solar PV development on the landscape. Higher resolution versions of these maps including bands A to E are contained in the accompanying document 'South Gloucestershire RERAS – Maps'.

<sup>264</sup> The sizes of solar PV developments indicate the areas taken up by solar PV panels only.

<sup>265</sup> Proposed solar PV developments larger than 60ha have not been considered in the LUC landscape sensitivity assessment. LUC has confirmed that landscape sensitivity to these very large schemes would be categorised as "high" sensitivity regardless of location, requiring developers to pay particular attention to this issue in their specific applications.

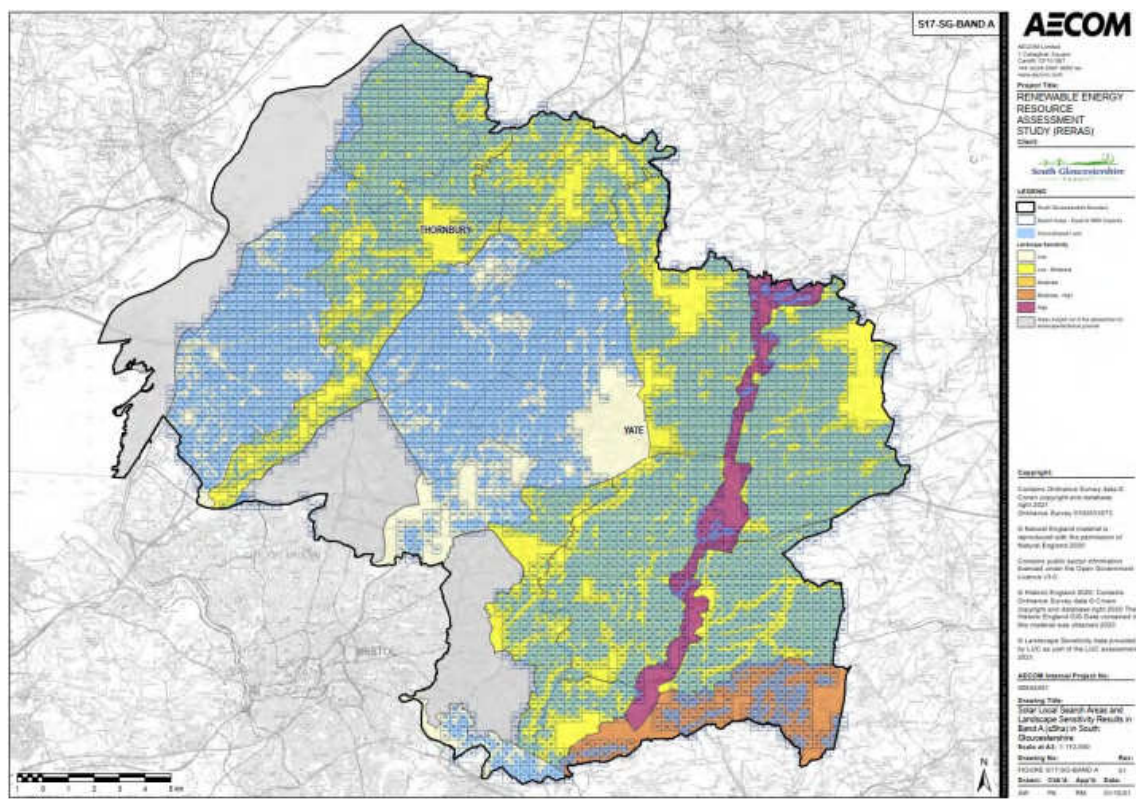

**Figure 118: S17-SG-Band A: Solar Local Search Areas from S6 Map and Landscape Sensitivity Results in Band A ( $\leq 5$ ha) in South Gloucestershire Map**

## H.6 Further Constraints to Solar PV Farm Sites

Further constraints to solar PV farm development that are not considered within this RERAS include (but are not necessarily restricted to):

- Practical access to sites required for the development;
- Landowner willingness for development to go ahead;
- National planning policies, which are outside of the Council's control;
- Community support; and
- Time to complete planning procedures.

## H.7 Potential Opportunities for Future Development

Solar PV has the potential to be a significant source of renewable energy generation in South Gloucestershire with the largest potential of any of the technologies in the study.

Across South Gloucestershire, 268.42km<sup>2</sup> of land was identified as suitable for a solar PV development, covering a significant amount of the rural land within South Gloucestershire.

These Search Areas can be further ranked using the results of the WPD grid connection analysis and the LUC landscape sensitivity assessment. The WPD grid connection analysis can be used to identify the most favourable locations when considering connection to the grid. The LUC landscape sensitivity assessment can guide the Council to the locations that will have the least environmental impact.

In relation to solar PV farm energy, potential opportunities for South Gloucestershire could be:

- Investment interest of Energy Services Companies (ESCOs);
- South Gloucestershire Council involvement with ESCO to secure greater community benefits; and
- Solar PV farms can provide significant revenue streams.

## Appendix I : Solar PV Farms Primary Constraints Table

The detailed assumptions and list can be found in the table below:

Constraint	Buffer	Notes
Special Protection Areas (SPA) and foraging buffers	Extent only	
Special Areas of Conservation (SAC)	Extent only	
RAMSAR sites	Extent only	
National Nature Reserves (NNR)	Extent only	Not present in South Gloucestershire
Sites of Special Scientific Interest (SSSI)	Extent only	
Scheduled Monuments	Extent only	
Listed Buildings,	Extent only	
Registered Parks and Gardens	Extent only	
Registered Battlefields	Extent only	
Ancient Woodlands – a 15 metre buffer has been applied to avoid root damage <sup>266</sup>	Extent only	
Broadleaved Woodland, a 15-metre buffer has been applied to avoid root damage <sup>266</sup>	15m	The buffer has been applied to avoid root damage
Major transport infrastructure.	Extent only	
Minor transport infrastructure.	Extent only	
Existing buildings/settlements	Extent only	
Watercourses – including major, secondary, and minor rivers, canals, and lakes; - a 2-metre buffer has been applied to rivers and streams	2m	
MoD Sites	Extent only	
Operational and consented (but not yet constructed) renewables energy development sites (solar PV and wind)	Extent only	
Active mines/quarries	Extent only	
Local Nature Reserves	Extent only	

<sup>266</sup> <https://www.gov.uk/guidance/ancient-woodland-and-veteran-trees-protection-surveys-licences>

## Appendix J : Solar PV Farms Other Constraints Table

It was agreed that these constraints would need to be examined as part of preparing the Local Plan and, therefore, have not been constrained further in this assessment.

Constraint	Buffer	Notes
Other woodlands (Other than Broadleaved Woodland and Ancient Woodland)	Extent Only	
Area of Outstanding Natural Beauty (AONB)	Extent Only	
Natural England's Impact Risk Zones for Wind Development (IRZs)	Extent Only	
Minerals Safeguarding Areas	Extent Only	
Flood Zones	Extent Only	
National Trust Inalienable Land	Extent Only	
Green Belt <sup>267</sup>	Extent Only	
Agriculturally Classified Land	Extent Only	Grades 1 to 5, non-agricultural and urban classified land
Historic England Conservation Areas	Extent Only	
Consented (but not yet constructed) solar PV and wind developments where their planning permissions may have lapsed.	Extent Only	

<sup>267</sup> As stated in the NPPF, paragraph 151: 'When located in the Green Belt, elements of many renewable energy projects will comprise inappropriate development. In such cases developers will need to demonstrate very special circumstances if projects are to proceed. Such very special circumstances may include the wider environmental benefits associated with increased production of energy from renewable sources'

## Appendix K : Biomass Energy Resource

### K.1 Introduction

The focus of this section of the study is on establishing the potential biomass resource defined as either:

- Energy crops (e.g. miscanthus, short-rotation coppice, etc.); or,
- Wood fuel resource.

Unlike wind farms, biomass can be utilised for the generation of both electricity and heat, and domestic hot water (DHW). The use of energy crops, forestry residues and recycled wood waste for energy generation can have a number of advantages:

- Provide opportunities for agricultural diversification;
- Encourage increased management of woodland;
- Can have positive effects on biodiversity;
- Remove biodegradable elements from the waste stream; and
- Potential for CO<sub>2</sub> savings.

In relation to biomass, the Biomass in a Low Carbon Economy<sup>268</sup> report by the Climate Change Committee (CCC) states:

---

*“Sustainably harvested biomass can play a significant role in meeting long-term climate targets, provided it is prioritised for the most valuable end-uses.”*

---

The report also confirms a significant potential to increase domestic production of sustainable biomass to meet between the equivalent of 5% and 10% of energy demand from UK sources by 2050. More information regarding biomass technology can be found in Section 1.8.6.

There are currently two large-scale dedicated biomass installations in South Gloucestershire. The first is an 8.3MW generator at Power Electrics Generators Limited, Warmley; and the other is a 0.96MW generator at Tesco Stores Ltd, Avonmouth.

### K.2 Energy Crops

#### Mapping

The potential energy crop resource in South Gloucestershire was determined by, utilising GIS maps, overlaying potential primary constraints onto the areas identified as having potential for growing such crops. The constraints were identified in consultation with South Gloucestershire Council.

Maps have been produced to illustrate each stage of the process of identifying primary constraints and also maps that identify the extent of the area of land with potential opportunities.

The flowchart shown in Figure 119 shows the process steps and the outputs at each mapping stage. More detail on the series of steps is provided in this section.

---

<sup>268</sup> <https://www.theccc.org.uk/wp-content/uploads/2018/11/Biomass-in-a-low-carbon-economy-CCC-2018.pdf>



**Figure 119: Flowchart of Energy Crop Mapping Process**

The titles/references correspond with maps in the accompanying document 'South Gloucestershire RERAS – Maps'.

### Step 1: Land Area for Energy Crops Cultivation

Map Reference and Title:

#### 1. B1-SG: Potential Biomass Resource Map (Grade 4 Agricultural Land)

In order to avoid competition between land uses (i.e. food crops, livestock grazing, energy crops, etc), Agricultural Land Classification (ALC) land grades 1, 2 and 3 are constrained out and not considered further. Therefore, this study assumed that energy crops could only be grown on agricultural land of Grade 4<sup>269,270</sup> which is not constrained by environmental or historical protected areas. These constraints are considered in the following mapping step.

B1 map illustrates the Grade 4 agricultural land across South Gloucestershire, which amounts to 36.07km<sup>2</sup>.

A higher resolution version of this map is contained in the accompanying document 'South Gloucestershire RERAS – Maps'.

<sup>269</sup> Poor quality agricultural land. Land with severe limitations which significantly restrict the range of crops and/or level of yields. It is mainly suited to grass with occasional arable crops (e.g. cereals and forage crops) the yields of which are variable. In moist climates, yields of grass may be moderate to high but there may be difficulties in utilisation. The grade also includes very droughty arable land.

<sup>270</sup>The Bioeconomy Consultants (2012), Domestic Energy Crops; Potential and Constraints Review, A report for DECC, URN: 12D/081; [https://assets.publishing.service.gov.uk/government/uploads/system/uploads/attachment\\_data/file/48342/5138-domestic-energy-crops-potential-and-constraints-r.PDF](https://assets.publishing.service.gov.uk/government/uploads/system/uploads/attachment_data/file/48342/5138-domestic-energy-crops-potential-and-constraints-r.PDF)



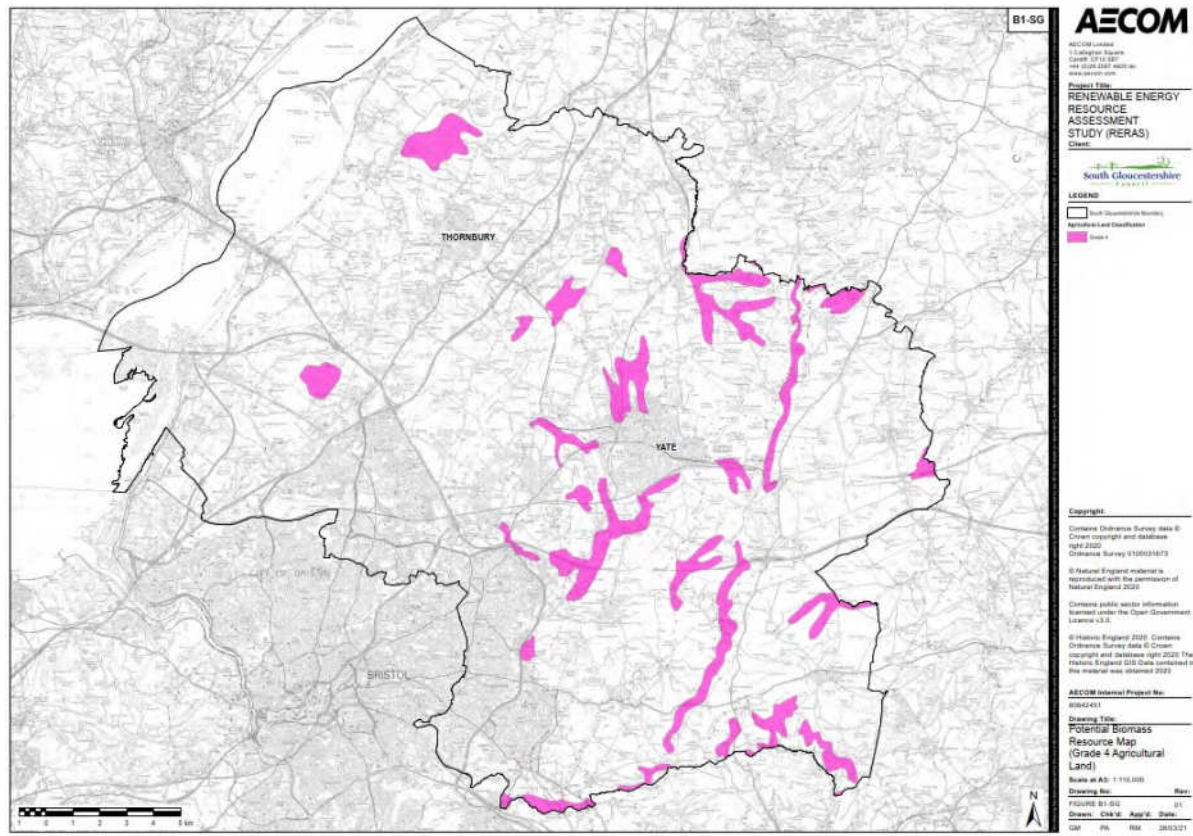

**Figure 120: B1-SG: Potential Biomass Resource Map (Grade 4 Agricultural Land) Map**

## Step 2: Primary Constraints to Biomass Energy Crops Resource

Map Reference and Title:

### 1. B2-SG: Biomass Resource Constraints – Areas to Exclude from Further Consideration

To further establish the potential biomass energy crops resource across South Gloucestershire, consideration was given to the primary constraints associated with restrictions to harvesting energy crops. The assessment used the following primary constraints:

- Areas of broadleaved woodland;
- Areas of environmental protection (including ancient woodlands);
- Areas of historical and cultural importance; and
- Operational and consented (but not yet constructed) renewables energy development sites (solar PV and wind).

A comprehensive table of the constraints is provided at Appendix L, and B2 map illustrates these constraints. A higher resolution version of this map is contained in the accompanying document 'South Gloucestershire RERAS – Maps'.

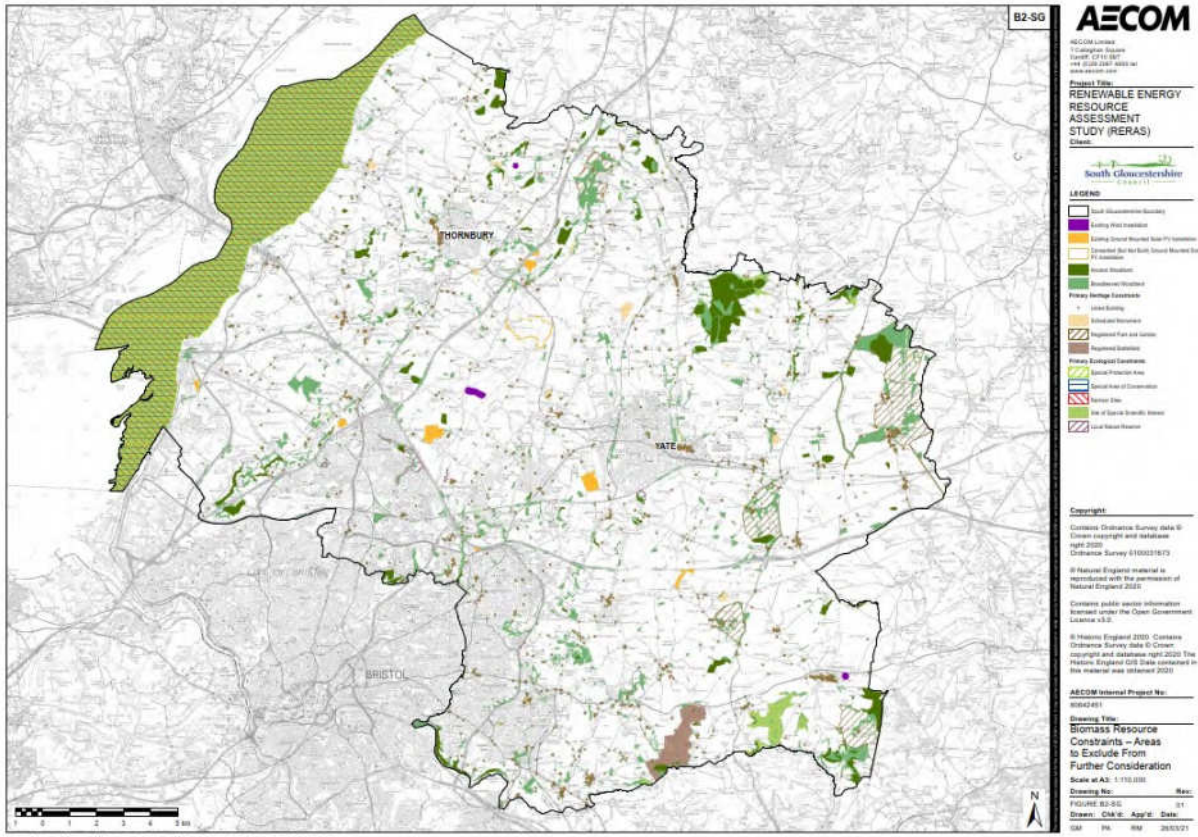

**Figure 121: B2-SG: Biomass Resource Constraints – Areas to Exclude from Further Consideration Map**

### Step 3: Remaining Land After Applying the Constraints and Crop Yield

Map Reference and Title:

1. B3-SG: Remaining Biomass Resource (Grade 4 Agricultural Land) After Constraining of Ancient and Broadleaved Woodlands, Primary Heritage and Ecological Constraints and Existing and Consented Renewable Generation Installations

B3 map shows the remaining available land for energy crop cultivation after removing the constrained areas in Step 2 of the mapping process.

The theoretical maximum area of land that could be planted with energy crops across South Gloucestershire is 29.03km<sup>2</sup>.

**Policy Recommendation**

**Policy Reference: BM-PR-1 (Refer to Table 43 in Section 17)**

It is recommended that proposals utilising biomass are looked upon favourably where:

- a. a whole life carbon benefit can be evidenced; and
- b. the development should be located away from urban areas (and preferably in areas off the gas grid).

A higher resolution version of this map is contained in the accompanying document 'South Gloucestershire RERAS – Maps'.

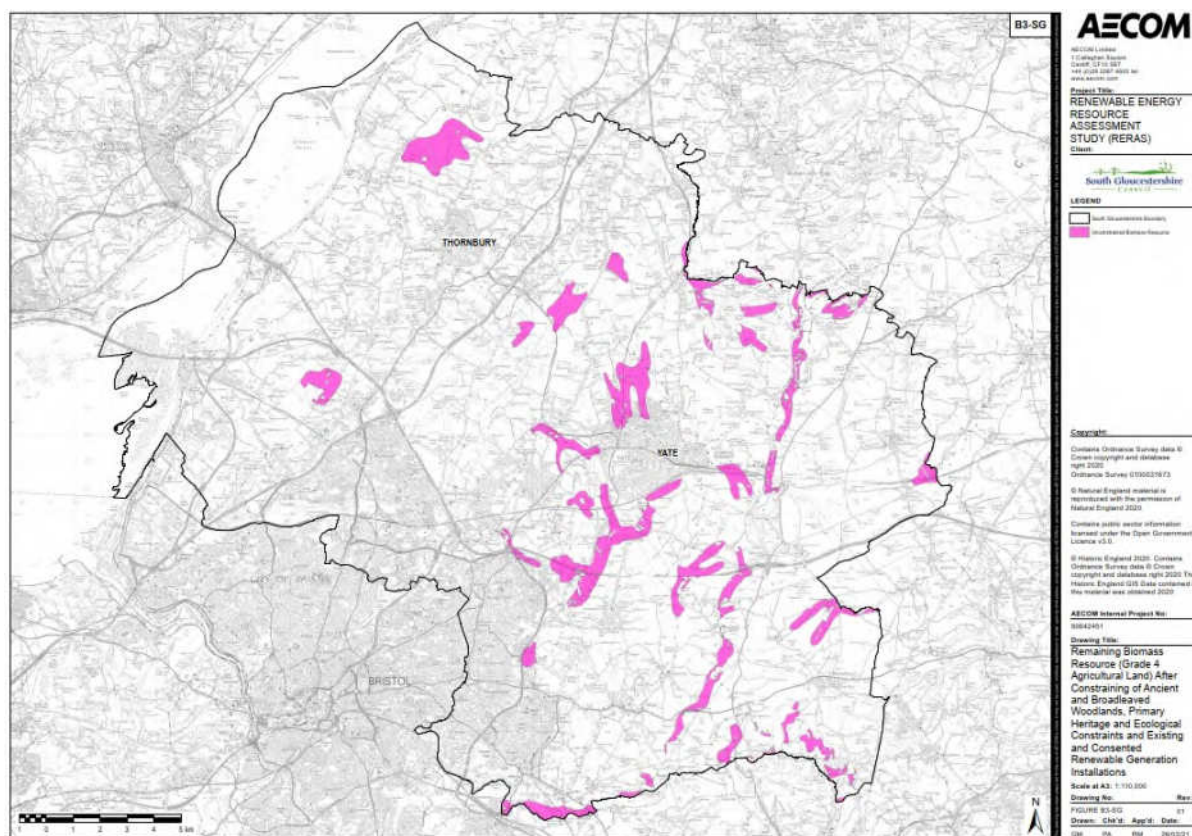

**Figure 122: B3-SG: Remaining Biomass Resource (Grade 4 Agricultural Land) After Constraining of Ancient and Broadleaved Woodlands, Primary Heritage and Ecological Constraints and Existing and Consented Renewable Generation Installations Map**

Competition with other crops, existing areas of energy crop cultivation, livestock grazing, solar PV farms, and unsuitable topography provide limitations on where energy crops can be planted



### Installed Power and Heat Generation Capacity

Forest Research<sup>271</sup> gives a figure of 7 to 12 oven-dry tonnes/ha/annum yield for short rotation coppice and 12 to 14 oven-dry tonnes (odt)/ha/annum yield for miscanthus. However, in reality, the actual yield will vary within a range, depending on a number of factors such as land grade, crop species, soil types, how many years a particular crop has been established at a site, and so on. Therefore, an average figure of 11 odt per hectare for energy crop yield was assumed in potential installed capacity calculations.

The amount of energy that could potentially be produced from biomass will depend on whether the fuel is burnt in boilers that only generate heat or combusted in Combined Heat and Power units (where the heat is used).

For the purposes of this assessment, it was assumed that the energy crop resource is used to fuel a biomass CHP system to produce electricity and heat.<sup>272</sup>

<sup>271</sup> <https://www.forestresearch.gov.uk/tools-and-resources/biomass-energy-resources/fuel/energy-crops/>

<sup>272</sup> This is an average figure to cover a range of different technology types, and sizes, with different efficiencies. For example, a smaller scale facility (about 2MWe) using a steam turbine with an efficiency of about 20%, might require up to 8,000 oven dry tonnes/annum. However, a larger facility (5-10MWe), using gasification, with an efficiency of up to 30%, might require about 5,000 oven dry tonnes per annum.

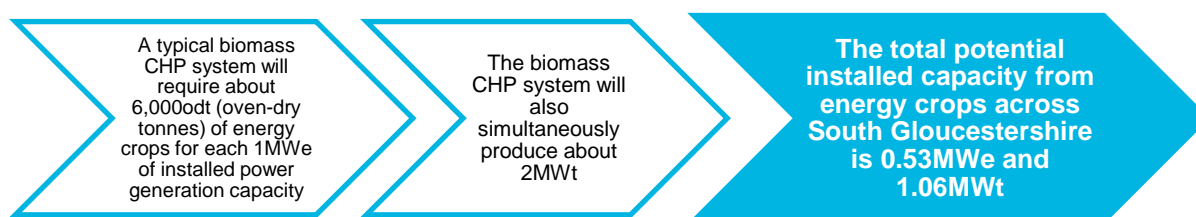

Table 67 confirms the maximum potential energy crop resource in South Gloucestershire.

**Table 67: Total Potential Energy Crop Resource in South Gloucestershire in 2030**

**Energy Crop Resource in 2030**

Total Available Area (km <sup>2</sup> )	29.03
Usable Area (km <sup>2</sup> )	2.90
Yield (odt per km <sup>2</sup> )	1,100
Yield (odt)	3,193
Required Yield per MWt	6000
<b>Potential Installed Capacity (MWe)</b>	<b>0.53</b>
Heat to Power Ratio	2:1
<b>Potential Installed Capacity (MWt)</b>	<b>1.06</b>

The potential installed capacity for energy crops across South Gloucestershire of 0.53MWe and 1.06MWt, is, for comparison, is equal to supplying energy to 46 typical primary schools annually<sup>273</sup>

### K.3 Wood Fuel

#### Usable Land and Yield

Wood fuel can be harvested from the small round wood stems, tips and branches of felled timber trees and thinning, and poor-quality round wood.<sup>274</sup>

Forest Research<sup>275</sup> confirms that 200 oven-dried tonnes of wood fuel per km<sup>2</sup> of woodland per annum could be available<sup>276</sup>.

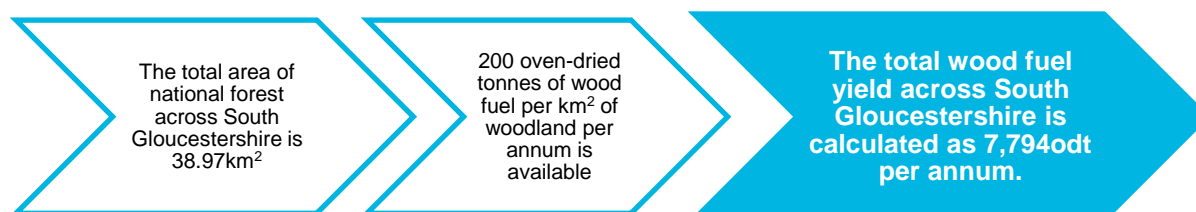

#### Installed Power and Heat Generation Capacity

The amount of energy that could potentially be produced from biomass will be dependent on whether the fuel is burnt in boilers that only generate heat or combusted in Combined Heat and Power units.

For the purposes of this assessment, it was assumed that the energy resource from wood fuel is utilised for SH or DHW or both (i.e. a biomass boiler<sup>277</sup>).

<sup>273</sup> DEC database is used to calculate average annual heat demand in a typical primary school.

<sup>274</sup> National forest is all wood land within the National Forestry Inventory. i.e. All woodland 0.5 hectares and over <https://www.forestresearch.gov.uk/tools-and-resources/national-forest-inventory/about-the-nfi/>

<sup>275</sup> <https://www.forestresearch.gov.uk/tools-and-resources/biomass-energy-resources/reference-biomass/facts-figures/potential-yields-of-biofuels-per-ha-pa/>

<sup>276</sup> The figures are based on forestry residues, short round wood (SRW), thinnings, etc.

<sup>277</sup> Assuming a boiler efficiency of 80% and a capacity factor of 0.3



Table 68 below confirms the maximum potential wood fuel biomass resource in South Gloucestershire.

**Table 68: Total Potential Energy Resource from Wood Fuel in South Gloucestershire**

Wood Fuel in 2030	
Available Area (km <sup>2</sup> )	38.97
Yield (odt per km <sup>2</sup> )	200
Yield (odt)	7,794
Required Yield per MWt	660
<b>Potential Installed Capacity (MWt)</b>	<b>11.8</b>

There is a maximum potential installed capacity from Wood Fuel across South Gloucestershire of 11.8MWt, equivalent to supplying energy to 168 typical primary schools annually<sup>278</sup>.

It should be noted this is the maximum potential resource (yield) which in reality will be reduced further by other constraints such as local demand, economic viability and other use of the wood. Some of the constraints are discussed in the following section.

### Further Constraints to Biomass Energy Resource

Where areas of land have been indicated as having potential for the growing of energy crops, further detailed studies are required prior to action. Furthermore, market demand is likely to play a vital role in what type of crop is grown, the location and quantity.

Even where there is a local demand for a biomass supply, constraints (not considered within this RERAS) can persist, including the proximity of supply to the plant and practical access to sites required to prepare and deliver fuel.

Further constraints to biomass that are not considered within this RERAS include (but are not necessarily restricted to:

- Landowner willingness;
- National planning policies, which are outside of the Council's control; and
- The time involved in the planning process.

Biomass is most usually utilised in CHP for industrial purposes (typically situated away from residential development) or for heating non-domestic buildings, particularly in non-urban off-gas areas where there are less likely to be Air Quality issues and sufficient room for fuel storage and access for delivery vehicles.

## 17.6 Potential Opportunities for Future Development

The potential available biomass resource within South Gloucestershire amounts to 0.53MWe and 12.86MWt which equates to 45.11GWht annually. This resource can be used to meet part of the heating demand in South Gloucestershire via renewables, including for use in individual boilers, via district heating networks or incorporated in a fuel electricity plant or CHP plant. It should be noted that the projected biomass use in South Gloucestershire in further sections is less biomass than the resource identified. Therefore, the amount of generation provided in further sections for 2030 aligns with the projected demand with the assumption that all biomass is sourced locally.

<sup>278</sup> DEC database is used to calculate average annual heat demand in a typical primary school.

Due to the finite supply of biomass, it is essential to ensure that the resource is used to its biggest advantage. A recent report from the Climate Change Committee<sup>279</sup> (CCC) states that biomass should only be used to sequester atmospheric carbon whilst simultaneously providing useful energy; this could include future opportunities for bioenergy with carbon capture and storage, which can provide a useful method for offsetting residual greenhouse gas emissions. Biomass should also only be considered in situations where there are few alternatives.

Alongside concerns relating to the finite supply of biomass resource, there are also health concerns associated with the emissions released as part of the process of burning biomass; for more information on this, see Section 1.8.6.2.

The above concerns should not deter the Council from maximising the use of the available biomass resource; however, consideration must be taken to ensure the most appropriate way of exploiting this resource is determined. Because of the flexibility of biomass fuel, it is suggested that a bespoke, independent and thorough investigation is conducted into any proposals received in respect of biomass projects, to ensure environmental benefit is secured.

Given the cost of CCUS projects, it may be that such projects are limited in the South Gloucestershire area. However, other projects potentially involving industrial manufacture/process, green hydrogen demonstration and production of biofuels may well be environmentally beneficial, particularly in off-gas grid areas where coal or oil is being displaced and where the biomass source is local and from sustainably managed sources.

In relation to biomass energy generation, potential opportunities for South Gloucestershire Council are:

- Investment interest of Energy Services Companies (ESCOs) may be secured through the identification of appropriate sites and heat demand; and
- Biomass fed renewable installations can provide significant revenue streams to the Council, including from the Renewable Heat Incentive.

---

<sup>279</sup> Climate Change Committee, 'Biomass in a Low-Carbon Economy, 2018; <https://www.theccc.org.uk/wp-content/uploads/2018/11/Biomass-in-a-low-carbon-economy-CCC-2018.pdf>

## Appendix L : Biomass Energy Resource Primary Constraints Table

The detailed data sources and assumptions can be found in the table below:

Constraint	Buffer	Notes
Special Protection Area (SPA)	Extent only	
Special Area of Conservation (SAC)	Extent only	
RAMSAR	Extent only	
SSSI	Extent only	
National Nature Reserves	Extent only	
Registered Parks and Gardens	Extent only	
Scheduled Monuments	Extent only	
Listed Buildings	Extent only	
BMV agricultural land grades 1, 2, 3a	Extent only	In order to avoid competition between food crops and livestock with fuel crops, land grades of 1, 2 and 3 are constrained out. Therefore, this study has assumed that energy crops can only be potentially grown on agricultural land of Grade 4 <sup>280,281</sup>
Local Nature Reserves	Extent only	
Broadleaved Woodland	Extent only	
Ancient Woodland	Extent only	
Registered Battlefields	Extent only	
Operational and consented (but not yet constructed) ground mounted solar PV installation	Extent only	

<sup>280</sup> Poor quality agricultural land. Land with severe limitations which significantly restrict the range of crops and/or level of yields. It is mainly suited to grass with occasional arable crops (e.g. cereals and forage crops) the yields of which are variable. In moist climates, yields of grass may be moderate to high but there may be difficulties in utilisation. The grade also includes very droughty arable land.

<sup>281</sup>The Bioeconomy Consultants (2012), Domestic Energy Crops; Potential and Constraints Review, A report for DECC, URN: 12D/081  
Prepared for: South Gloucestershire Council

## Appendix M : Energy from Waste

### M.1 Introduction

The Waste Management Plan for England<sup>282</sup> contains the Government's ambitions to work towards a more sustainable and efficient approach to resource use and waste management. The plan states that all waste management plans must include measures so that, by 2035:

- Re-use and the recycling of municipal waste is increased to a minimum of 65% by weight.
- The amount of municipal waste landfilled is reduced by 10% or less of the total amount of municipal waste generated (by weight)

The West of England Joint Waste Core Strategy<sup>283</sup> (JWCS) sets out the strategic spatial planning policy for the provision of waste management infrastructure across the planning area. The plan aims to reduce the amount of waste taken to landfill by increasing waste minimisation, recycling and composting, then recovering further value from any remaining waste.

The JWCS highlights that, although material recovery takes priority, energy recovery has a beneficial role to play in both sustainable waste management and as a low carbon energy source from an Energy from Waste (EfW) plant.

The South Gloucestershire Resource and Waste Strategy<sup>284</sup> includes local recycling targets for South Gloucestershire, these are as follows:

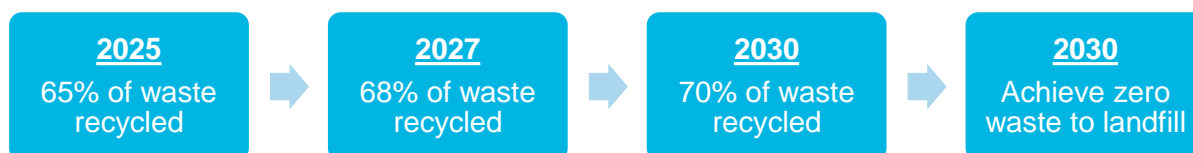

Part of the pathway to achieving these targets, includes using Energy Recovery Facilities (ERFs) for non-recyclable waste. The West of England partnership (South Gloucestershire, North Somerset, Bath and North East Somerset and Bristol City) use two ERFs to incinerate waste and produce energy for the National Grid.

This section determines the amount of potential electricity and heat generation available from the following waste generators:

- Municipal Solid Waste;
- Commercial and Industrial (C&I) Waste;
- Food Waste;
- Agricultural Waste (Animal Manure and Poultry Litter); and
- Sewage Sludge.

For more information regarding the technologies used, see Section 1.8.6.

<sup>282</sup> Waste Management Plan for England, DEFRA, 2021; [https://assets.publishing.service.gov.uk/government/uploads/system/uploads/attachment\\_data/file/955897/waste-management-plan-for-england-2021.pdf](https://assets.publishing.service.gov.uk/government/uploads/system/uploads/attachment_data/file/955897/waste-management-plan-for-england-2021.pdf)

<sup>283</sup> West of England Joint Waste Core Strategy, WEP, March 2011; <https://www.westofengland.org/waste-planning/adopted-joint-waste-core-strategy>

<sup>284</sup> South Gloucestershire Resource and Waste Strategy: 2020 and Beyond, South Gloucestershire Council, 2020, <https://beta.southglos.gov.uk/wp-content/uploads/1654-Resource-and-Waste-Strategy-2020-and-beyond-v1.0.pdf>



## M.2 Municipal Solid Waste

The total predicted Municipal Solid Waste (MSW) across South Gloucestershire was provided by the Council based on the council's waste prediction model.

To avoid conflict with existing recycling targets, it was assumed that only 30% of this waste stream would be available for energy recovery.

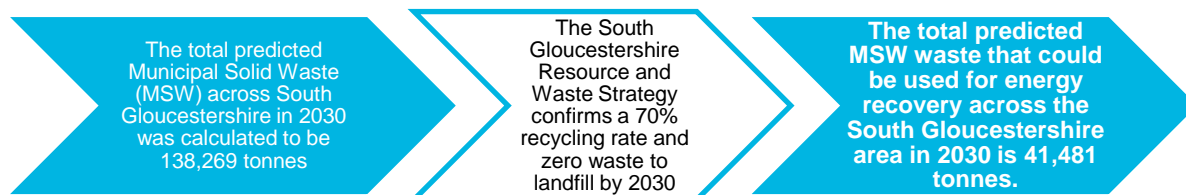

EfW facilities that generate electricity typically have gross efficiencies of about 27%<sup>285</sup>. However, England's Resources and Waste Strategy confirms the Government will seek greater efficiency of EfW plants by encouraging the use of the heat the plants produce. Many plants are already Combined Heat and Power (CHP)-enabled and can utilise the generated heat if they can find a customer for it. South Gloucestershire Council also supports the development of a heat network from EfW facilities<sup>286</sup>. Therefore, it was assumed that MSW waste would be burnt in facilities that produce CHP with higher efficiency levels (typically of around 40%) where the heat is usefully employed<sup>287</sup>.

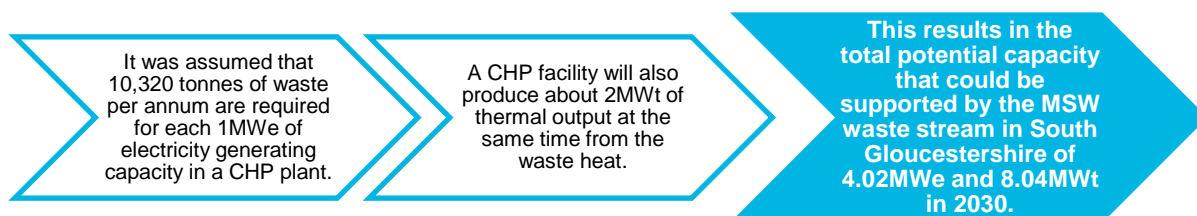

However, only the Biodegradable (BD) fraction of energy generation from waste would be classified as renewable energy<sup>288</sup>.

The current Renewables Obligation guidance<sup>289</sup> includes a minimum level of the biodegradable fraction of MSW of 50%. However, the UK Government consultation on the re-banding of the Renewables Obligation suggested that high rates of recycling could result in residual biomass energy content in the range 30–38%<sup>290, 291</sup>.



Table 69 provides a breakdown for the MSW calculations.

<sup>285</sup> Our Waste, Our Resources: A Strategy for England, HM Government, 2018;

[https://assets.publishing.service.gov.uk/government/uploads/system/uploads/attachment\\_data/file/765914/resources-waste-strategy-dec-2018.pdf](https://assets.publishing.service.gov.uk/government/uploads/system/uploads/attachment_data/file/765914/resources-waste-strategy-dec-2018.pdf)

<sup>286</sup> <https://www.southglos.gov.uk/environment-and-planning/planning/planning-policy/superseded-plans/minerals-and-waste-local-plan/>

<sup>287</sup> This assumes an electricity generation efficiency of 25%, based on a net calorific value of the fuel of 11MJ/kg, and a capacity factor of 0.9. This assumed calorific value of the fuel is a rough average as the actual value can vary widely depending on the composition of the waste, the extent to which recyclables and wet biodegradable waste has been removed or source separated, and whether the fuel has already been processed into RDF pellets.

<sup>288</sup> Directive 2009/28/EC of the European Parliament and of the Council; on the promotion of the use of energy from renewable sources and amending the subsequently repealing Directives 2001/77/EC and 2003/30/EC, 2009

<sup>289</sup> Renewables Obligation: Fuel Measurement and Sampling, OFGEM, April 2020

<sup>290</sup> See Annex E: Analysis on Deeming the Fossil Fuel Fraction of Waste of the Government Response to the Statutory Consultation on the Renewables Obligation Order 2009, December

<sup>291</sup> Reform of the Renewables Obligation, DECC, December 2008

**Table 69: Municipal Solid Waste Resource for the South Gloucestershire Area in 2030**

<b>Municipal Solid Waste in 2030</b>	
Total waste (tonnes)	138,269
Total residual waste (tonnes)	41,481
Required wet tonnes per 1MWe	10,320
Potential installed capacity (MWe)	4.02
Total renewable element	35%
<b>Potential installed capacity (MWe)</b>	<b>1.41</b>
Heat to power ratio	2:1
<b>Potential installed capacity (MWt)</b>	<b>2.81</b>

Currently, waste is exported to Severnside and Viridor energy recovery centres in South Gloucestershire and Bristol respectively. Waste that is unsuitable for EfW is put in landfill at a site outside of South Gloucestershire in Wiltshire. The South Gloucestershire Resource and Waste Strategy 2020 confirms that in 2018 less than 10% of the total waste went to landfill. However, it has been confirmed the landfilled waste proportion has been reduced since 2018 and the site is being used only as a contingency.

Therefore, the exported portion of the resource is covered by existing contracts (i.e. it is counted as renewable generation in other areas) and the additional resource that will be used in the EfW plant in South Gloucestershire is a part of the existing installed capacity. Hence, this resource is counted as existing generation in South Gloucestershire or elsewhere and no additional potential was assumed for 2030.

### M.3 Commercial and Industrial Waste

The potential for generating energy using C&I waste streams is challenging to assess as there is no central data holding, and this would need to be explored through regional intelligence on producers and managers of C&I waste. The collection of C&I waste is outside the remit of South Gloucestershire, although the Council collects a small amount of waste from commercial buildings such as schools.

The Environment Agency's Waste Data Interrogator (WDI) was used to calculate the total C&I waste arising across South Gloucestershire<sup>292</sup>. The dataset is designed primarily to provide data for waste planners and waste management professionals. It contains details of all waste received and removed from permitted waste facilities in England, including hazardous waste, but not from exempted facilities.

The amount of MSW collected by the Council was subtracted from the total collected waste figure reported in WDI for South Gloucestershire to calculate the amount of C&I waste arising within South Gloucestershire. The figure amounts to 400,345 tonnes of waste in 2019. It should be noted this figure includes waste streams such as concrete, bricks, tiles and ceramics from Construction and Demolition (C&D) waste which will not be suitable for incineration. Therefore, the inert C&D waste proportion was subtracted further from the C&I arising waste figure. Inert waste is waste that does not undergo any significant physical, chemical or biological transformations<sup>293</sup>

In order to calculate the predicted C&I waste across South Gloucestershire in 2030, targets from the "Sustainability Turn" scenario of the "Scenario-Building for Future Waste Policy" report were utilised<sup>294</sup>. The research was commissioned and funded by the Department for Environment, Food and Rural Affairs (DEFRA), and the "Sustainability Turn" assumes an overall sustainability turn by society, industry, and politics whilst focusing on the principle of avoiding waste. The scenario predicts a 7% reduction in C&I Waste Arisings between 2020 and 2030.

<sup>292</sup> <https://data.gov.uk/dataset/d409b2ba-796c-4436-82c7-eb1831a9ef25/2019-waste-data-interrogator>

<sup>293</sup> <https://www.gov.uk/guidance/landfill-operators-environmental-permits/landfills-for-inert-waste>

<sup>294</sup> [http://sciencesearch.defra.gov.uk/Document.aspx?Document=WR1508\\_FutureWasteScen\\_FinalReport\\_FORPUBLICATION.pdf](http://sciencesearch.defra.gov.uk/Document.aspx?Document=WR1508_FutureWasteScen_FinalReport_FORPUBLICATION.pdf)

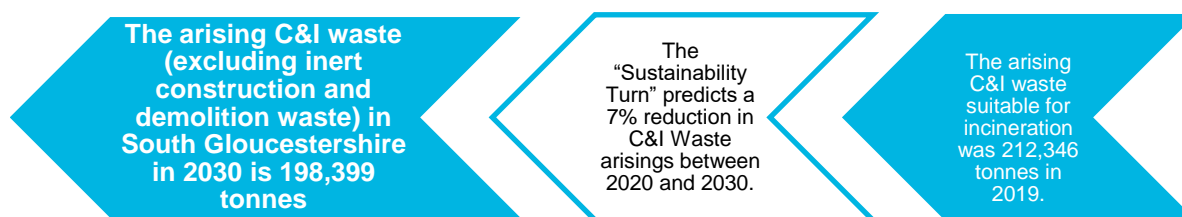

To avoid conflict with existing recycling targets, it was assumed that only 30% of this waste stream would be available for energy recovery.



It was assumed that C&I waste will be burnt in facilities that produce CHP with higher efficiency levels (typically of around 40%) where the heat is usefully employed, as per England's Waste and Resource Strategy.<sup>295</sup>

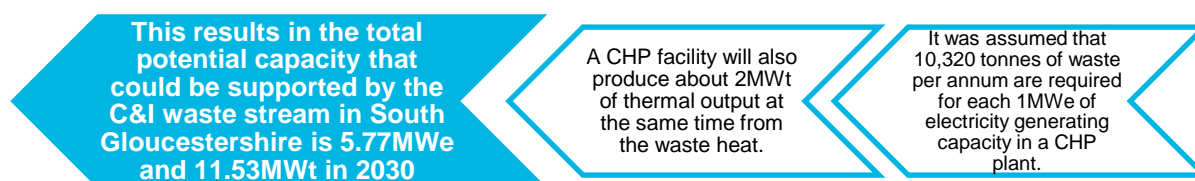

However, only the Biodegradable (BD) fraction of energy generation from waste would be classified as renewable energy<sup>297</sup>.

The current Renewables Obligation guidance<sup>298</sup> includes a minimum level of the biodegradable fraction of MSW of 50%. However, the UK Government consultation on the re-banding of the Renewables Obligation suggested that high rates of recycling could result in residual biomass energy content in the range 30–38%<sup>299, 300</sup>.

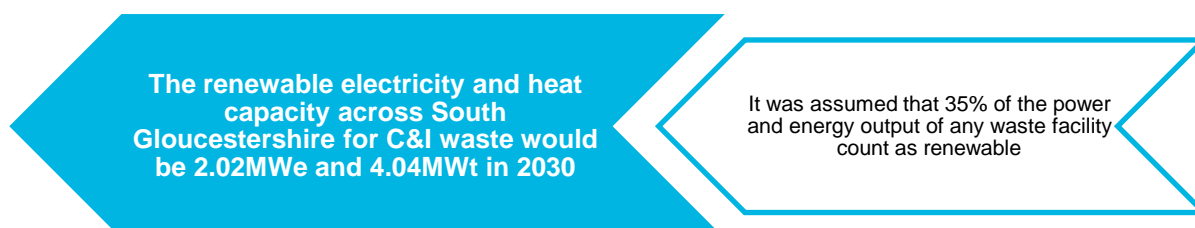

<sup>295</sup> This assumes an electricity generation efficiency of 25%, based on a net calorific value of the fuel of 11MJ/kg, and a capacity factor of 0.9. This assumed calorific value of the fuel is a rough average as the actual value can vary widely depending on the composition of the waste, the extent to which recyclables and wet biodegradable waste has been removed or source separated, and whether the fuel has already been processed into RDF pellets.

<sup>296</sup> This assumes an electricity generation efficiency of 25%, based on a net calorific value of the fuel of 11MJ/kg, and a capacity factor of 0.9. This assumed calorific value of the fuel is a rough average as the actual value can vary widely depending on the composition of the waste, the extent to which recyclables and wet biodegradable waste has been removed or source separated, and whether the fuel has already been processed into RDF pellets.

<sup>297</sup> Directive 2009/28/EC of the European Parliament and of the Council; on the promotion of the use of energy from renewable sources and amending the subsequently repealing Directives 2001/77/EC and 2003/30/EC, 2009

<sup>298</sup> Renewables Obligation: Fuel Measurement and Sampling, OFGEM, April 2020

<sup>299</sup> See Annex E: Analysis on Deeming the Fossil Fuel Fraction of Waste of the Government Response to the Statutory Consultation on the Renewables Obligation Order 2009, December

<sup>300</sup> Reform of the Renewables Obligation, DECC, December 2008

**Table 70: Commercial and Industrial waste resource in South Gloucestershire in 2030**

Commercial and Industrial Waste in 2030	
Total waste (tonnes)	198,399
Total residual waste (tonnes)	59,520
Required wet tonnes per 1MWe	10,320
Potential installed capacity (MWe)	5.77
Total renewable element	35%
<b>Potential installed capacity (MWe)</b>	<b>2.02</b>
Heat to power ratio	2:1
<b>Potential installed capacity (MWt)</b>	<b>4.04</b>

Based on the WDI data, the bulk of residual waste is currently exported to facilities outside South Gloucestershire. It is unknown if the existing arrangement will be in place until 2030. Therefore, it was assumed that this resource is counted as existing generation elsewhere until the end of 2030.

## M.4 Food Waste

The data for the tonnes of food waste collected in South Gloucestershire in 2019/20 was collected from DEFRA data.

As South Gloucestershire's population rises from 285,093, in 2019, to a projected 319,854<sup>301</sup>, in 2030, it is expected that the amount of household waste produced will also increase. South Gloucestershire Council has predicted that there will be a total of 138,269 tonnes of MSW in 2030<sup>302</sup>. The figure is 15.1% higher compared to the 120,088 tonnes of MSW produced in 2019/20.

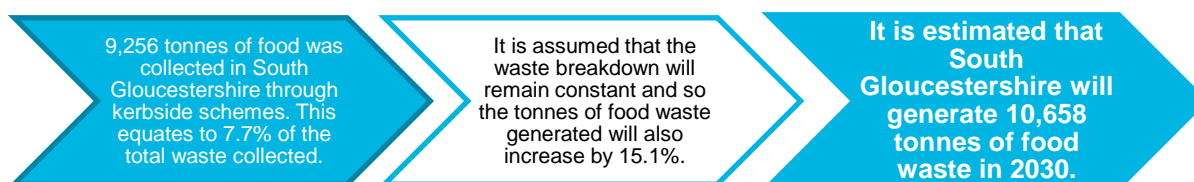

Food waste can be anaerobically digested to produce a gas that is suitable for combustion and, if the plant is suitably enabled, generate both electric and heat.<sup>303, 304</sup>

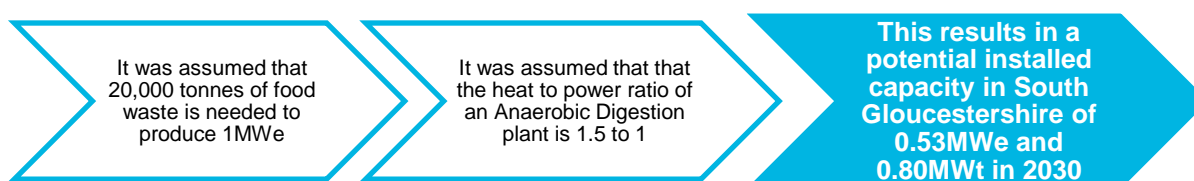

<sup>301</sup> Office for National Statistics – Population Projections for Local Authorities: Table 2  
<https://www.ons.gov.uk/peoplepopulationandcommunity/populationandmigration/populationprojections/datasets/localauthoritiesnenglandtable2>

<sup>302</sup>Data from the South Gloucestershire waste prediction model developed by Ricardo AEA

<sup>303</sup>This assumes the following: : 1 tonne of wet food waste produces 140m<sup>3</sup> of biogas (Dealing with Food Waste in the UK, Eunomia, March 2007 - Table 10 - <https://www.yumpu.com/en/document/read/24424418/dealing-with-food-waste-in-the-uk-march-2007-wrap>); 1m<sup>3</sup> of biogas has an energy content of 5.8kWh; an electrical generating efficiency of 30% and a capacity factor of 0.9

<sup>304</sup>Combine Heat and Power, Technologies A detailed guide for CHP developers, BEIS, February 2021;  
[https://assets.publishing.service.gov.uk/government/uploads/system/uploads/attachment\\_data/file/961492/Part\\_2\\_CHP\\_Technologies\\_BEIS\\_v03.pdf](https://assets.publishing.service.gov.uk/government/uploads/system/uploads/attachment_data/file/961492/Part_2_CHP_Technologies_BEIS_v03.pdf)

**Table 71: Potential Installed Capacity from Total Available Food Waste Resource in the South Gloucestershire in 2030**

Resource from Food Waste in 2030	
MSW food waste (tonnes)	10,658
Required tonnes per MWe	20,000
<b>Potential installed capacity (MWe)</b>	<b>0.53</b>
Heat to Power Ratio	1.5:1
<b>Potential installed capacity (MWt)</b>	<b>0.80</b>

The South Gloucestershire Resource and Waste Strategy<sup>305</sup> highlights that a substantial amount of food waste is placed in the black bin rather than being recycled - in 2019, 32.9% of the recyclable waste found in the black bins was food waste. The council intends to tackle this issue by offering information and advice to its residents on reducing food waste.

Although the campaigns aim to reduce the amount of food waste being produced, as awareness on food waste recycling increases, it is still likely that the available food waste will increase.

Food waste from South Gloucestershire is currently treated in Avonmouth, in Bristol. Assuming that the existing arrangements continue, the food waste is already accounted for as existing generation elsewhere. Therefore, no energy generation from food waste is assumed in South Gloucestershire for 2030.

## M.5 Agricultural Waste

### Animal Manure

It was assumed that the farming mix will not change significantly in South Gloucestershire over the time period to 2030, and therefore the potential for energy generated from agricultural waste will be the same as the current scenario.

Utilising the latest statistics (2016), the total numbers of cattle and pigs across South Gloucestershire is 30,581 and 3,695, respectively<sup>306, 307</sup>.



In practice, it is unlikely to be possible or practical to collect all of the potential resource. This is because many farms will not use a slurry system but will collect the excreta as solid manure mixed with bedding which is then spread on the fields.<sup>308</sup>

<sup>305</sup> South Gloucestershire Resource and Waste Strategy: 2020 and Beyond, South Gloucestershire Council, 2020; <https://beta.southglos.gov.uk/wp-content/uploads/1654-Resource-and-Waste-Strategy-2020-and-beyond-v1.0.pdf>

<sup>306</sup> Structure of the agricultural industry in England and the UK at June - structure-june-eng-localauthority-09jan18

<sup>307</sup> East of England Renewable and Low Carbon Energy Capacity Study, AECOM, May 2011; <https://www.eastsuffolk.gov.uk/assets/Planning/Suffolk-Coastal-Local-Plan/Document-Library/Infrastructure/east-of-england-renewable-energy-capacity-study.pdf>

<sup>308</sup> East of England Renewable and Low Carbon Energy Capacity Study, AECOM, May 2011; <https://www.eastsuffolk.gov.uk/assets/Planning/Suffolk-Coastal-Local-Plan/Document-Library/Infrastructure/east-of-england-renewable-energy-capacity-study.pdf>

Furthermore, it will not be practical to collect the slurry from some of the farms, because they may be too small or too dispersed for this to be economically viable.<sup>309</sup>



An Anaerobic Digestion plant would be suitable to treat animal slurry and be CHP enabled to generate both electricity and heat<sup>310, 311, 312</sup>

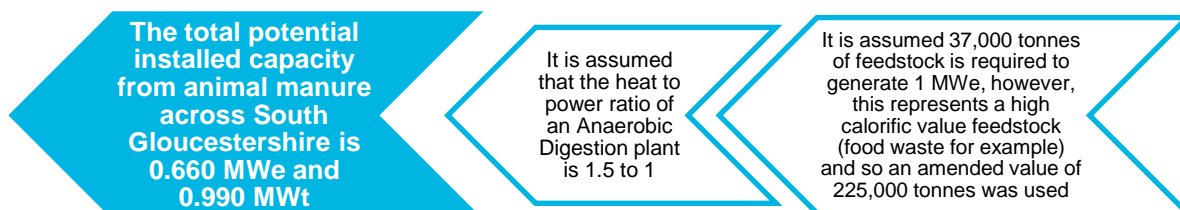
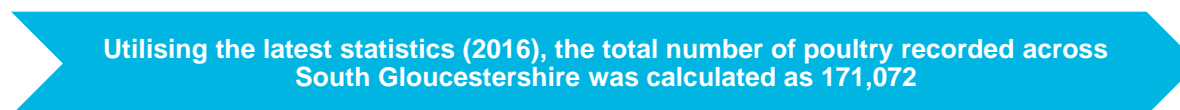

**Table 72: Potential Installed Capacity from Total Available Animal Slurry Resource in the South Gloucestershire in 2030**

Animal Slurry Resource in 2030	
Total livestock (Cattle & Pigs)	34,276
Total slurry (tonnes)	185,703
Usable slurry (tonnes)	148,562
Required wet tonnes per MWe	225,000
<b>Potential installed capacity (MWe)</b>	<b>0.660</b>
Heat to power ratio	1.5:1
<b>Potential installed capacity (MWt)</b>	<b>0.990</b>

### Poultry Litter

It is assumed that the farming mix in South Gloucestershire will not change over the time period to 2030, and that the potential energy generated from agricultural waste will be the same as the current scenario.



DEFRA provides information on the amount of excreta produced by different types of poultry<sup>313, 314, 315</sup>.

<sup>309</sup> Renewable and Low-carbon Energy Capacity Methodology, DECC, January 2010; [https://assets.publishing.service.gov.uk/government/uploads/system/uploads/attachment\\_data/file/226175/renewable\\_and\\_low\\_carbon\\_energy\\_capacity\\_methodology\\_jan2010.pdf](https://assets.publishing.service.gov.uk/government/uploads/system/uploads/attachment_data/file/226175/renewable_and_low_carbon_energy_capacity_methodology_jan2010.pdf)

<sup>310</sup> Combine Heat and Power, Technologies A detailed guide for CHP developers, BEIS, February 2021; [https://assets.publishing.service.gov.uk/government/uploads/system/uploads/attachment\\_data/file/961492/Part\\_2\\_CHP\\_Technologies\\_BEIS\\_v03.pdf](https://assets.publishing.service.gov.uk/government/uploads/system/uploads/attachment_data/file/961492/Part_2_CHP_Technologies_BEIS_v03.pdf)

<sup>311</sup> Renewable and Low-carbon Energy Capacity Methodology, DECC, January 2010; [https://assets.publishing.service.gov.uk/government/uploads/system/uploads/attachment\\_data/file/226175/renewable\\_and\\_low\\_carbon\\_energy\\_capacity\\_methodology\\_jan2010.pdf](https://assets.publishing.service.gov.uk/government/uploads/system/uploads/attachment_data/file/226175/renewable_and_low_carbon_energy_capacity_methodology_jan2010.pdf)

<sup>312</sup> East of England Renewable and Low Carbon Energy Capacity Study, AECOM, May 2011; <https://www.eastsuffolk.gov.uk/assets/Planning/Suffolk-Coastal-Local-Plan/Document-Library/Infrastructure/east-of-england-renewable-energy-capacity-study.pdf>

<sup>313</sup> See the DEFRA leaflets on guidance to farmers in Nitrate Vulnerable Zones, Leaflet 3, Table 3

<sup>314</sup> Based on the figure for laying hens, which is 3.5 tonnes per month

<sup>315</sup> Renewable and Low-carbon Energy Capacity Methodology, DECC, January 2010 See above link

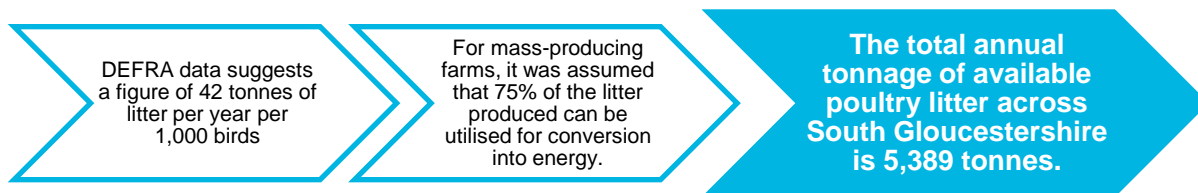

A bespoke CHP plant would need to be used to facilitate the poultry litter resource.

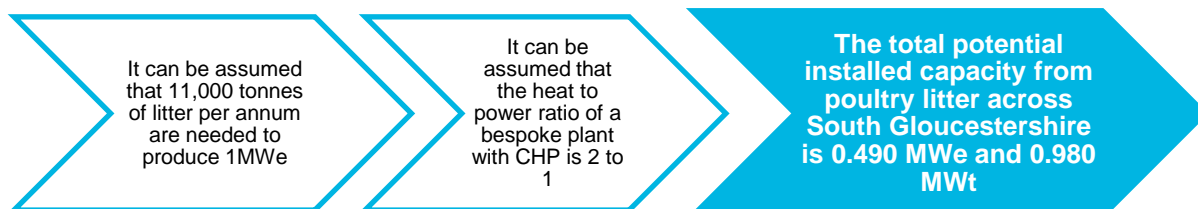

**Table 73: Potential Installed Capacity from Poultry Litter in the South Gloucestershire in 2030**

Poultry Litter Resource in 2030	
Total poultry	171,072
Accessible Poultry (75%)	128,304
Total litter (tonnes)	5,389
Required tonnes of litter per MWe	11,000
<b>Potential installed capacity (MWe)</b>	<b>0.490</b>
Heat to power ratio	2 :1
<b>Potential installed capacity (MWt)</b>	<b>0.980</b>

In practice, as the potential capacity is less than 10MWe, it is unlikely that this would be enough to support a dedicated poultry litter power plant.

Given the total combined resource from animal slurry and poultry litter is 1.150 MWe and 1.970 MWt, the resource could be combined with animal slurry to support an anaerobic digestion facility of 1.150 MWe.

## M.6 Sewage Sludge

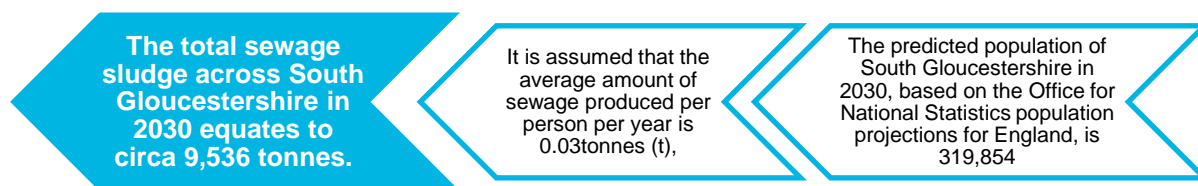

An Anaerobic Digestion plant would be suitable for utilising sewage sludge to produce both electric and heat.<sup>316, 317</sup>

<sup>316</sup> The biogas production figure was provided by AECOM engineers who are specialists in designing AD plants for the water industry

<sup>317</sup>Combine Heat and Power, Technologies A detailed guide for CHP developers, BEIS, February 2021 [https://assets.publishing.service.gov.uk/government/uploads/system/uploads/attachment\\_data/file/961492/Part\\_2\\_CHP\\_Technologies\\_BEIS\\_v03.pdf](https://assets.publishing.service.gov.uk/government/uploads/system/uploads/attachment_data/file/961492/Part_2_CHP_Technologies_BEIS_v03.pdf)

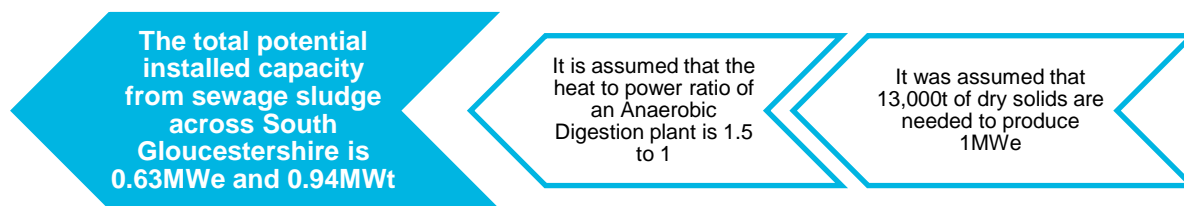

**Table 74: Potential Installed Capacity from Total Available Sewage Sludge Resource in South Gloucestershire in 2030**

<b>Sewage Sludge Resource in 2030</b>	
South Gloucestershire Population	319,854
Sewage per person (tonnes)	0.03
Total Sewage (tonnes)	9,596
Required tonnes of sewage per MWe	13,000
<b>Potential installed capacity (MWe)</b>	<b>0.63</b>
Heat to Power Ratio	1.5:1
<b>Potential installed capacity (MWt)</b>	<b>0.94</b>

## M.7 Waste Summary

A summary of the potential energy generation from the waste resource in South Gloucestershire is provided below. There are a number of key considerations which would impact whether the resource can be exploited:

- Viability of any investment in a plant;
- Existing arrangements and contracts;
- Origin and price/gate fees of the resource.

High level consideration was given to the likelihood of the resource being exploited.

Although there is available food waste resource in the area, the waste is processed in Avonmouth, and it is understood that the existing arrangements are likely to be in place until 2030. Therefore, given resource availability is determined by where the generation takes place for the purposes of this report, it is assumed there is no available energy resource from food waste

There is an existing large EfW site within the South Gloucestershire area, and therefore, the residual waste exported to the site is assumed to be existing generation.

A bespoke CHP plant would need to be used to facilitate the poultry litter resource. However, in practice, as the potential capacity is less than 10MWe, it is unlikely that this would be enough to support a dedicated poultry litter power plant since it is likely not to be viable. The resource has therefore been combined with slurries to be utilised in an AD plant with CHP

Given that there is already recovery of landfill gas utilised for electricity generation in South Gloucestershire, it is assumed that all economic opportunities are being exploited – hence the contribution is set to zero.

Therefore, the only available resources that can be utilised in AD plants within South Gloucestershire are animal slurries or sewage sludge.

When considering all of the above, the final potential for renewable energy from the waste resource is shown in Table 75 below.



**Table 75: Summary of Energy from Waste**

Resource	Technology	Prior to Consideration of Likelihood of Utilisation for RE Generation		Reason for Adjustment / Change of Technology	Post Consideration of Likelihood of Utilisation for RE Generation 2030		
		2030			Technology	MWe	MWt
		MWe	MWt				
C&I Waste	EfW with CHP	2.02	4.04	It is currently recycled, and the bulk of residual waste is exported to facilities outside South Gloucestershire. Therefore, it is counted as an existing generation elsewhere.	None	-	-
MSW	EfW with CHP	1.41	2.81	It is currently recycled. Non-recyclable material is exported to Severnside and Viridor energy recovery centres in South Gloucestershire and Bristol, respectively. Therefore, it is counted as existing generation in South Gloucestershire or elsewhere.	None	-	-
Food Waste	AD with CHP	0.53	0.80	Currently processed in Bristol Avonmouth, in the West of England. Assuming that the existing arrangements remain until 2030, the food waste is already accounted for as existing generation elsewhere.	None	-	-
Animal Slurry	AD with CHP	0.66	0.99	Combined with Poultry Litter	AD	1.150	1.970
Poultry Litter	Bespoke plant with CHP	0.49	0.98	Not likely to be enough resource for bespoke plant. This resource is therefore combined with Animal slurry for AD with CHP above.	None	-	-
Sewage Sludge	AD with CHP	0.63	0.94	.	AD	0.63	0.94
Landfill Gas	Landfill gas recovery engine			There is a 9.76MWe installed capacity, it is assumed that all economic opportunities have already been exploited.	None		
<b>Potential installed capacity</b>		<b>5.74</b>	<b>10.56</b>			<b>1.78</b>	<b>2.91</b>

## Appendix N : Future Energy Scenarios

The National Grid Electricity Systems Operator's (ESO) produces Future Energy Scenarios (FES) annually<sup>318</sup>, containing in-depth analysis of different future scenarios in the energy system within the UK (see Section 14). The 2020 FES have been updated to reflect the UK Governments net zero by 2050 targets. It should be noted that the 'Steady Progression' scenario would not meet the 2050 net zero target. The four scenarios are described below:

### 1. Steady Progression

- Low levels of decarbonisation and societal change.
- Not compliant with the 2050 net zero emissions target.

### 2. System Transformation

- High level of decarbonisation with lower societal change. Larger, more centralised solutions are developed. This scenario has the highest levels of hydrogen deployment.

### 3. Consumer Transformation

- High levels of decarbonisation and societal change. Consumers adopt new technologies rapidly, and more decentralised solutions are developed. This scenario has significant electrification of domestic heat.

### 4. Leading the Way

- Very high levels of decarbonisation and societal change. Consumers adopt new technologies rapidly, and a mix of solutions are developed. This scenario aims for the "fastest credible" decarbonisation pathway

The UK FES total annual energy (end consumer) and the consumption for residential, industrial and commercial and road transport sectors for each scenario can be seen below in Figure 123 to Figure 126. The figures outline the projected consumption by fuel type within each of the 4 FES scenarios at the UK wide level.

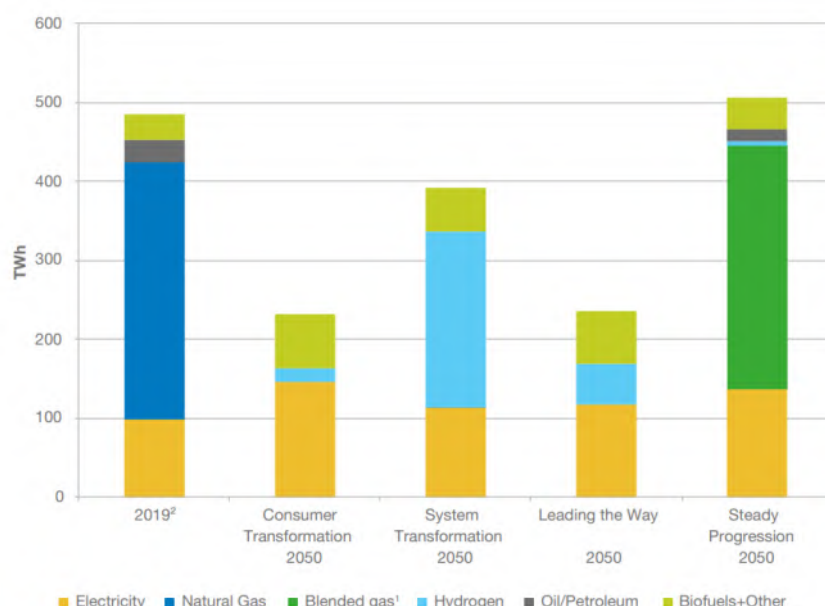

**Figure 123: UK 2019 and Projected Annual Residential Energy Consumption (for heat appliances) in the UK<sup>319</sup>**

<sup>318</sup> Future Energy Scenarios, National Grid ESO, July 2020; <https://www.nationalgrideso.com/document/173821/download>

<sup>319</sup> National Grid ESO, Future Energy Scenarios, July 2020; <https://www.nationalgrideso.com/document/173821/download>

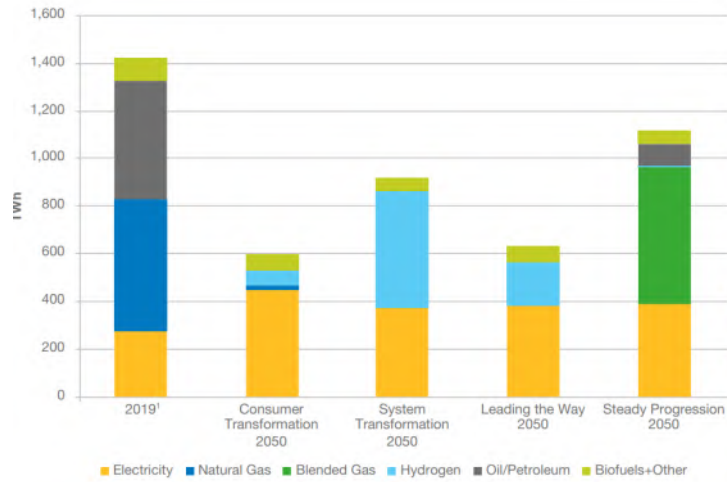

Figure 124: UK 2019 and Projected Annual End Consumer Energy Consumption in the UK<sup>320</sup>

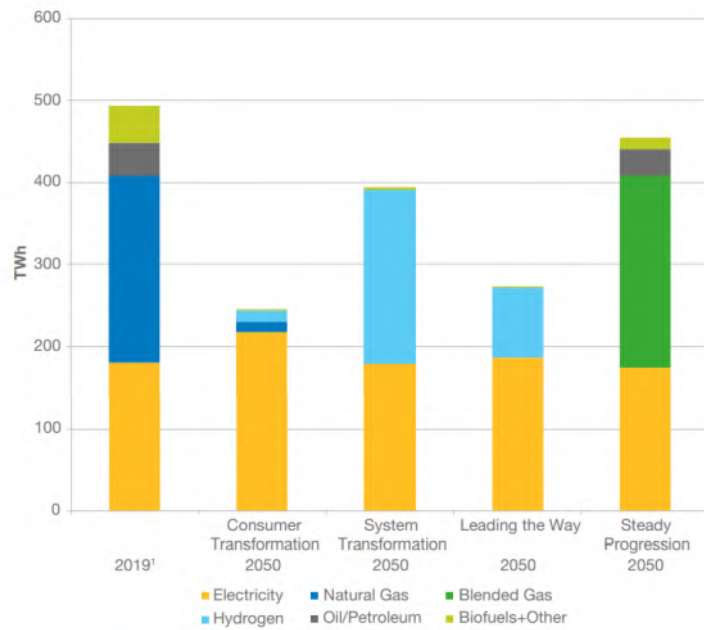

Figure 125: UK 2019 and Projected Annual Industrial and Commercial Energy Consumption in 2050<sup>320</sup>

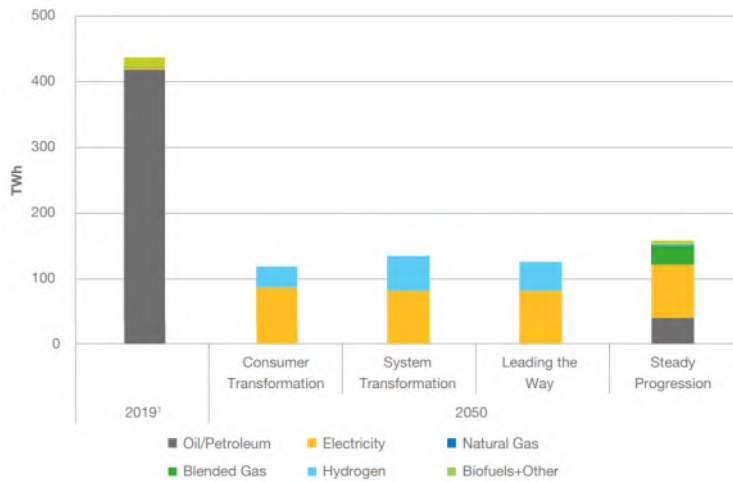

Figure 126: UK Total Annual Consumption for Road Transport in 2050<sup>320</sup>

<sup>320</sup> National Grid ESO, Future Energy Scenarios, July 2020; <https://www.nationalgrideso.com/document/173821/download>  
Prepared for: South Gloucestershire Council

As shown in Figure 126, the use of a low amount of natural gas is still projected in the commercial and industrial sectors in 2050 under the Consumer Transformation scenario. The implication of this is that there will need to be a degree of offset.

Table 76 below details the predicted UK 2050 greenhouse gas emissions for each scenario under the FES, highlighting residual emission in industry, power generation and “Other” category. The ‘Other’ category includes Agriculture, Land Use and Land Use Change and Forestry (LULUCF), Waste, F-gases, Aviation and shipping which are not within the scope of RERAS.

The data shows the fundamental use of Bioenergy with Carbon Capture and Storage (BECCS) in achieving net zero emissions. BECCS is the combination of bioenergy with carbon capture and storage to capture any CO<sub>2</sub> released during combustion, and the FES assumes that the greenhouse gases released in each scenario will be mainly offset by using BECCS.

**Table 76: UK 2050 Greenhouse Gas Emissions by Category**<sup>321,322</sup>

MtCO <sub>2</sub> equivalent	2019	CT 2050	ST 2050	LW 2050	SP 2050
Heat for buildings	87	0	0	0	78
Electricity before BECCS	57	3	2	2	30
BECCS in power sector	0	-52	-49	-61	0
Industry	102	4	4	4	55
Road transport	113	0	0	0	16
Hydrogen production	0	0	-1	0	0
Other	121	45	45	45	79
<b>Total</b>	<b>480</b>	<b>0</b>	<b>0</b>	<b>-10</b>	<b>258</b>

<sup>321</sup> National Grid ESO, Future Energy Scenarios, July 2020; <https://www.nationalgrideso.com/document/173821/download>

<sup>322</sup> Note that some of these figures do not add up exactly due to rounding

## Appendix O : Renewable Energy Generation Load Factors

The area-wide resource assessment results indicate the potential installed capacity for different technologies (in MW) that the available resource can support. A well-established and straightforward way of estimating how much energy the potential capacity might generate is to use capacity factors (as load factors).

These factors, which vary by technology, measure how much energy a generating station will typically produce in a year for any given installed capacity. A summary of the different capacity factors for different technologies are given below.

Technology	Load Factors	Comments and Sources
Onshore Wind	0.25	Average of the five previous years' regional standard load factors published by BEIS. <sup>323</sup>
Biomass (Electricity)	0.75	Average of the five previous years' regional standard load factors. DUKES 2020.
Biomass (Heat)	0.40	This allows for the fact that not all of the waste heat can be usefully used 100% of the time.
Hydropower	0.29	Average of the five previous years' regional standard load factors published by BEIS <sup>323</sup> .
Energy from Waste (Electricity)	0.90	Typical for gas and coal fired power stations <sup>324</sup> . It should be noted in this study, calculation is based on only biodegradable waste capacity.
Energy from Waste (Heat)	0.50	This allows for the fact that not all of the waste heat can be usefully used 100% of the time
Landfill Gas (Electricity)	0.46	Average of the five previous years' regional standard load factors published by BEIS <sup>323</sup> .
Landfill Gas (Heat)	0.30	This allows for the fact that not all of the waste heat can be usefully used 100% of the time
Anaerobic Digestion Including Food Waste, Animal Slurry, Poultry Litter, Sewage Sludge and Sewage Gas. (AD with CHP)	0.43	Average of the five previous years' regional standard load factors published by BEIS <sup>323</sup> .
Anaerobic Digestion Utilising Food Waste, Animal Slurry, Poultry Litter, Sewage Sludge and Sewage Gas. (Heat)	0.5	This allows for the fact that not all of the waste heat can be usefully used 100% of the time
Solar Farm	0.11	Average of the five previous years' regional standard load factors published by BEIS <sup>323</sup> .
Domestic and Non-Domestic Renewable Electricity Technologies Such as Rooftop Solar PV (electricity)	0.10	This is an average for PV and micro and small wind
Domestic and Non-Domestic Renewable Thermal Technologies (Thermal)	0.20	This is an average across a range of technologies, covering heat pumps, wood chip and pellet boilers and solar water heating.

<sup>323</sup> <https://www.gov.uk/government/statistics/regional-renewable-statistics>

<sup>324</sup> Markal energy model, 2007, chapter 5 Project Sheet of model documentation, [www.ucl.ac.uk/energy-models/models/uk-markal/uk-markal-manual-chapter-5](http://www.ucl.ac.uk/energy-models/models/uk-markal/uk-markal-manual-chapter-5)  
Prepared for: South Gloucestershire Council

## Appendix P : Future Energy Demand Building Integrated Renewables Projections Data Source

This section includes details of the key data sources that are used in calculation of future energy demand and building integrated renewable technologies projections.

Source	Use	Description	Link
National Grid ESO FES 2020	Projections and scenario framework	National Grid ESO's Future Energy Scenarios (FES) represent a range of different ways to decarbonise the GB energy system. Represented as four scenarios, three of them meet net zero by 2050 at a national level.	<a href="#">Link.</a>
Western Power Distribution (WPD) and Regen DFES	Technology baseline and projections	The Distribution Future Energy Scenarios (DFES) outline the range of credible futures for the growth of the distribution network. Broadly aligning with the National Grid ESO's FES, these encompass the growth of demand, storage and distributed generation, also low carbon technologies such as Electric Vehicles and Heat Pumps at a local level.	<a href="#">Link.</a>
Ministry of Housing, Communities & Local Government (MHCLG) EPC data	Technology baseline	MHCLG publish Energy Performance Certificates and Display Energy Certificates data for buildings in England and Wales down to the granularity of individual houses. This provides highly detailed information on energy related information for buildings in a local area.	<a href="#">Link.</a>
BEIS Sub-national energy consumption statistics	Energy baseline	BEIS publish local data on energy consumption, including at local authority level, for different fuels and consumption sectors.	<a href="#">Link.</a>

## Appendix Q : Potential Hydropower Sites

The Win-Win (schemes that both provide a good hydropower opportunity and increase the status of the associated fish population beneficial both in terms of hydropower generation and environmental impact<sup>325</sup>) sites have been highlighted in the below table<sup>326</sup>.

OBSTRUCT ID	Feature	Power	Power Category	Sensitivity	Location
848	Weir	226.7206160000	100 - 500 kW	High	Avon & Frome
902	Weir	3.5347679200	0 - 10 kW	Medium	Avon & Frome
910	Weir	7.6374480000	0 - 10 kW	High	Avon & Frome
964	Weir	20.6841600000	20 - 50 kW	High	Avon & Frome
1206	Weir	9.7427132500	0 - 10 kW	High	Avon & Frome
1236	Weir	26.0853487000	20 - 50 kW	High	Avon & Frome
1324	Weir	0.3725017300	0 - 10 kW		Avon & Frome
1357	Weir	0.3370772400	0 - 10 kW		Avon & Frome
1369	Weir	0.0157260200	0 - 10 kW		Avon & Frome
1415	Weir	3.7781720500	0 - 10 kW		Avon & Frome
1424	Weir	0.2484682800	0 - 10 kW		Avon & Frome
1435	Weir	0.3589878300	0 - 10 kW		Avon & Frome
1454	Weir	0.9032836600	0 - 10 kW	High	Avon & Frome
1471	Weir	21.2725660000	20 - 50 kW	Medium	Avon & Frome
1486	Weir	3.8794047300	0 - 10 kW	Medium	Avon & Frome
1487	Weir	1.5412775400	0 - 10 kW	Medium	Avon & Frome
1500	Weir	0.1868059000	0 - 10 kW	Medium	Avon & Frome
1526	Weir	0.4281335300	0 - 10 kW		Avon & Frome
1532	Weir	2.8774841100	0 - 10 kW		Avon & Frome
1555	Weir	3.9717722800	0 - 10 kW		Avon & Frome
1562	Weir	2.8466935900	0 - 10 kW	Medium	Avon & Frome
1606	Weir	2.9008297300	0 - 10 kW		Avon & Frome
1628	Weir	0.3854804100	0 - 10 kW		Avon & Frome
1664	Weir	0.1008372900	0 - 10 kW		Avon & Frome
1681	Weir	0.7339061500	0 - 10 kW		Avon & Frome
1729	Weir	8.6702936800	0 - 10 kW	Medium	Avon & Frome
1740	Weir	19.4758443000	10 - 20 kW	High	Avon & Frome
1752	Weir	5.0316570800	0 - 10 kW	Medium	Avon & Frome
1771	Weir	0.3360295700	0 - 10 kW		Avon & Frome
1811	Weir	0.5912221500	0 - 10 kW		Avon & Frome
1813	Weir	0.0992779500	0 - 10 kW		Avon & Frome
1825	Weir	9.7999578200	0 - 10 kW	High	Avon & Frome
1920	Weir	3.1945309800	0 - 10 kW	Medium	Avon & Frome

<sup>325</sup> The Environmental Agency's judgement on whether the site is a potential "win-win" for both hydropower and the environment, Page 11

<sup>326</sup> Potential Sites of Hydropower Opportunity, Environment Agency, revised 2020; <https://data.gov.uk/dataset/cda61957-f48b-4b75-b855-a18060302ed1/potential-sites-of-hydropower-opportunity>

1922	Weir	0.8609762400	0 - 10 kW		Avon & Frome
1959	Weir	1.5094224400	0 - 10 kW	High	Avon & Frome
1982	Weir	0.3346360700	0 - 10 kW		Avon & Frome
1983	Weir	8.6204873900	0 - 10 kW	High	Avon & Frome
2027	Weir	4.2598983700	0 - 10 kW	Medium	Avon & Frome
2030	Weir	0.2884519200	0 - 10 kW		Avon & Frome
2074	Weir	0.9318836700	0 - 10 kW	High	Avon & Frome
2103	Weir	0.3826706000	0 - 10 kW		Avon & Frome
2109	Weir	0.1496966000	0 - 10 kW		Avon & Frome
2131	Weir	3.3124245700	0 - 10 kW	Medium	Avon & Frome
2218	Weir	0.1021367400	0 - 10 kW		Avon & Frome
2318	Weirs	0.3191448300	0 - 10 kW		Avon & Frome
2323	Weirs	0.5190001900	0 - 10 kW		Avon & Frome
2324	Weirs	0.4459711200	0 - 10 kW		Avon & Frome
2325	Weirs	0.3890552200	0 - 10 kW		Avon & Frome
2340	Weirs	0.2385789500	0 - 10 kW		Avon & Frome
2341	Weirs	0.2476751000	0 - 10 kW		Avon & Frome
2363	Waterfall	3.1747973400	0 - 10 kW	High	Avon & Frome
2367	Waterfall	8.1152169800	0 - 10 kW	High	Avon & Frome
2368	Waterfall	7.7134586100	0 - 10 kW	High	Avon & Frome
2405	Lock	575.3967610000	500 - 1500 kW	High	Avon & Frome
2673	Weir	7.2438765100	0 - 10 kW	High	Avon & Frome
2690	Weir	25.3682520000	20 - 50 kW	High	Avon & Frome
2708		6.9387236600	0 - 10 kW	Medium	Avon & Frome
2738	Weir	9.5766974500	0 - 10 kW	High	Avon & Frome
2739	Weir	9.6127196100	0 - 10 kW	High	Avon & Frome
2740	Weir	14.4597975000	10 - 20 kW	High	Avon & Frome
2797	Weir	18.2601379000	10 - 20 kW	High	Avon & Frome
2803	Weir	0.0664266900	0 - 10 kW		Avon & Frome
2845	Weir	0.7366229700	0 - 10 kW		Avon & Frome
2878	Waterfall	6.3495946800	0 - 10 kW	High	Avon & Frome
3460	Weir	0.9482411200	0 - 10 kW	High	Lower Severn
4434	Weir	0.8584980800	0 - 10 kW	High	Lower Severn



## Appendix R : Accelerating DFES 2050 Projection to 2030

Technology	Existing Installations (MWe)	Existing Generation (MWh/annum)	2050 DFES Projections	2030 Projections for South Gloucestershire	Total Generation in South Gloucestershire in 2030 Projections (MWh/annum)	Additional Capacity required to meet DFES (MWe)	Additional Generation required to meet DFES (MWh)	Number of 5MW Wind Farms/ 5MW Solar Farms Required
Onshore Wind <1MW	1.2950	1,134.42	4.88	4.88	4,278.09	3.59	3,143.67	3.81
Onshore Wind >=1MW	6.9000	15,018.60	22.35	22.35	48,647.21	15.45	33,628.61	
Onshore Wind <=0.006 MW	0.0170	14.89	0.088	0.09	77.38	0.07	62.49	
Commercial solar rooftop (10kW - 1MW)	9.1000	7,971.60	77.5	77.49	67,881.24	68.39	59,909.64	
Ground mounted solar (>1MW)	124.4000	120,660.04	218.1	218.13	211,572.15	93.73	90,912.10	1.87
Domestic solar rooftop (<10kW)	12.8820	11,284.63	143.2	143.16	125,410.21	130.28	114,125.58	
Domestic solar rooftop (>10kW)	0.0000	0.00	39.0	7.65	6,704.14	7.65	6,704.14	
Landfill Gas, Sewage Gas, Biogas	9.7580	39,546.11	0.436	0.44	1,767.64	-9.32	-37,778.46	
Hydropower	0.0010	2.50	0.001	0.001	2.50	0.00	0.00	
Large Scale Biomass	9.2780	61,361.49	9.278	9.278	61,361.49	0.00	0.00	
Waste Incineration (EfW)	9.6700	76,238.28	9.670	9.670	76,238.28	0.00	0.00	
<b>Total</b>	<b>183.30</b>	<b>333,232.57</b>			<b>603,940.35</b>	<b>309.84</b>	<b>270,707.78</b>	
<b>Percentage of 2030 Demand</b>		<b>11.19%</b>			<b>20.29%</b>		<b>9.09%</b>	

## Appendix S : Installation of Maximum Potential

This option assumes a 100% uptake of the potential installed capacity of solar PV farms and wind farms and the installation of other technologies, such as heat pumps, as set out in the DFES. It also assumes that projected energy consumption in 2050 occurs in 2030, excluding the demand from any new dwellings, which has stayed consistent with the current 2030 projections.

It should be noted the lack of grid connection opportunities may affect the ability of the Council to meet the 2030 aim under this scenario; therefore, more investment in the grid would be required to support a greater number of renewables than currently assumed needed from DFES.



*This option assumes that circa 73% of homes are primarily heated by heat pumps and that there will be a 24% increase in direct electric heating, in South Gloucestershire, as per the DFES.*



*This option assumes that there will be circa 270 times more electric vehicles than in 2020, in the South West, as per the DFES<sup>327</sup>.*



*This option could deliver a potential maximum energy of 12,221.3GWhe and 113.1GWht in South Gloucestershire.*

This option is the very ambitious and least realistic option due to the amount of new wind and solar development required. Further constraints such as competing land uses would need to be considered and a balance between other local objectives would need to be considered prior to any development.

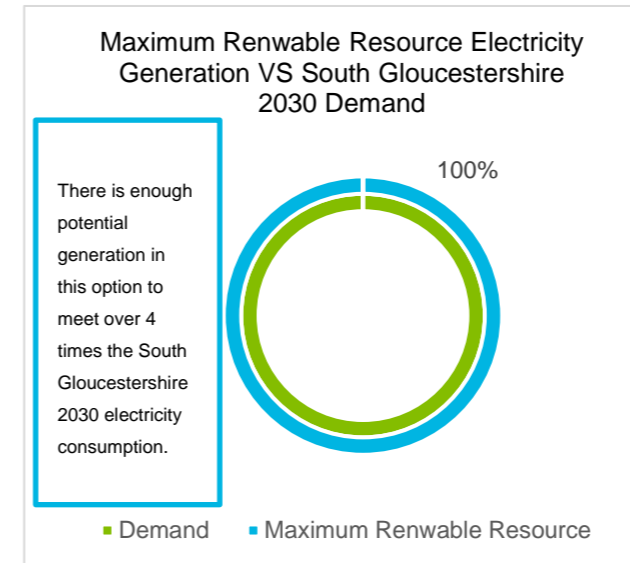

Figure 127: Comparison of 2030 Electricity Generation in this Option and South Gloucestershire's 2030 Consumption

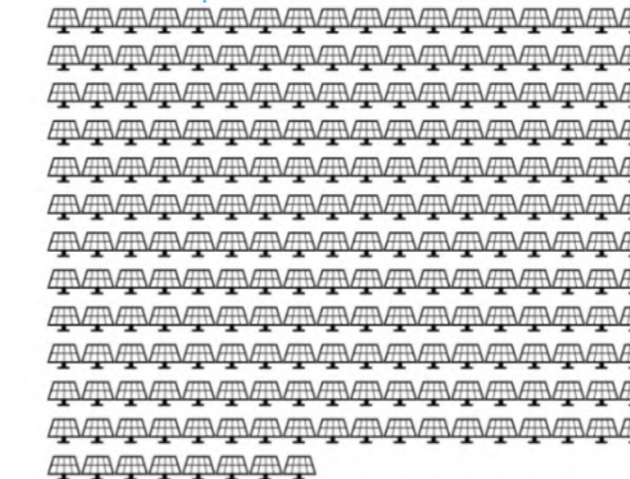

Figure 129: Pictogram of Number of Additional 50MW Solar Farms and 5MW Wind Farms Required in this Option<sup>328</sup>

Table 77: Potential Maximum Electricity Generation (GWh)

Technology	Potential Maximum Electricity Generation (GWh)
Energy from Waste	76.24
Hydropower	0.003
Landfill Gas	39.55
Large Scale Wind	872.14
Solar PV Farms	10,968.62
Other (incl. food waste, animal slurry, poultry litter and sewage sludge biogas and biomass)	64.66
Projected Building Integrated Wind Turbines	0.08
Projected PV - Rooftop	200.0

<sup>328</sup> Each solar panel icon is equivalent to one 50MW solar farm. Each wind turbine icon is equivalent to one 5MW wind farm

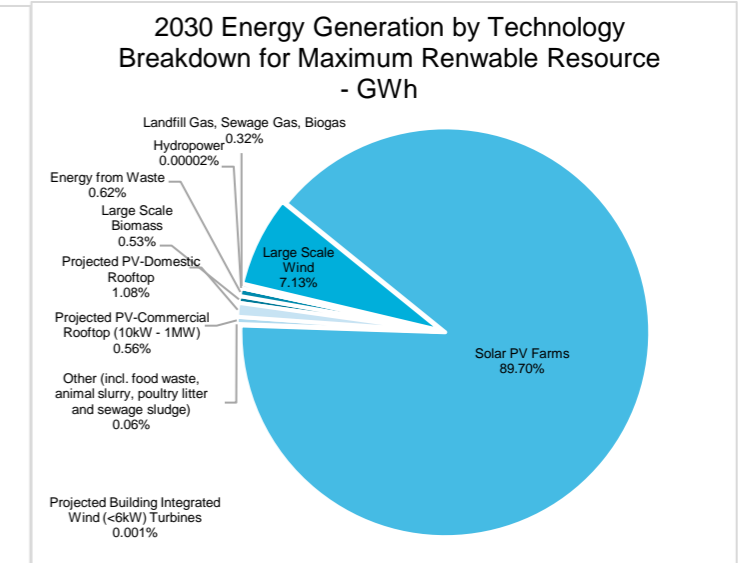
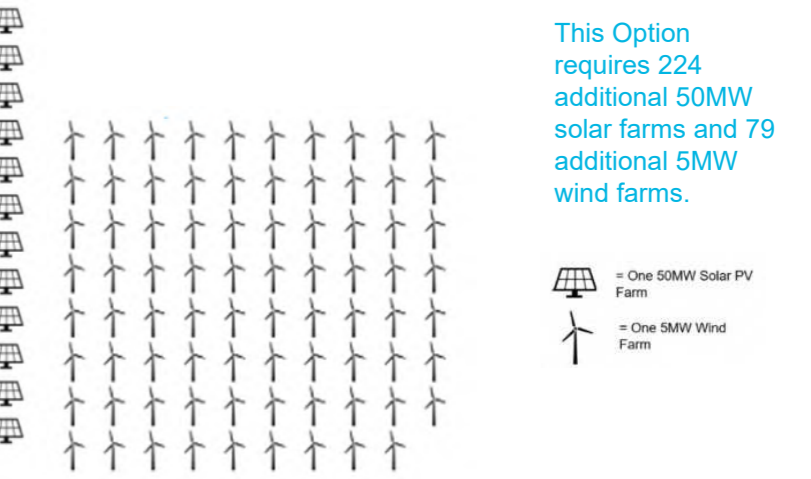

Figure 128: 2030 Energy Generation by Technology Breakdown in this Option - GWh



This Option requires 224 additional 50MW solar farms and 79 additional 5MW wind farms.

☀ = One 50MW Solar PV Farm  
 🌪 = One 5MW Wind Farm

<sup>327</sup> 7,000 EVs in baseline year and 1,894,000 EVs in 2030 in the South West licence area in Consumer Transformation scenario. <https://www.regen.co.uk/wp-content/uploads/WPD-DFES-2020-technology-summary-report-South-West.pdf>